



# HOWARD COUNTY DEPARTMENT OF PUBLIC WORKS

7125 Riverwood Drive, Suite B ■ Columbia, Maryland 21046 ■ 410-313-2414

Amah N. Binde, P.E., PMP, Bureau Chief  
Bureau of Engineering  
www.howardcountymd.gov

FAX 410-313-6144  
TDD 410-313-2323

Date: February 22, 2022  
To: Holders of Howard County Design Manuals  
Subject: Revisions to Howard County Design Manual  
Volume III – Roads and Bridges

Dear Sir or Madam:

On February 7, 2022 the Howard County Council, in its Legislative Session, approved Council Resolution No.17-2022 (CR17-2022) adopting revisions to Volume III of the Howard County Design Manual. This revision to the Design Manual modified Volume III to include Complete Streets concepts and best practices.

Specific changes to Volume III of the Design Manual include the following:

1. Content changes to reflect Howard County's Complete Streets Policy to ensure that Howard County roads are designed to accommodate "residents of all ages and abilities who travel by foot, bicycle, public transportation or automobile."
2. Renaming of the Howard County Design Manual Volume III to be "Complete Streets and Bridges"
3. Repealing of the Current Howard County Design Manual Volume III (Roads and Bridges)

The revised Design Manual Volume III can be accessed and / or downloaded by going to the Howard County website <https://www.howardcountymd.gov/planning-zoning/regulations-and-manuals>

All projects are subject to these revisions and shall utilize the current Volume III – Complete Streets and Bridges as noted in CR17-2022 effective the date of Council approval.

Very truly yours,

Bureau of Engineering

# County Council of Howard County, Maryland

2022 Legislative Session

Legislative Day No. 1

## Resolution No. 17 -2022

Introduced by: The Chairperson at the request of the County Executive

A RESOLUTION adopting a comprehensive revision to the Howard County Design Manual Volume III (Roads and Bridges) that includes content changes; renaming the Howard County Design Manual Volume III to be "Complete Streets and Bridges"; amending the Howard County Design Manual Volume IV (Standard Specifications and Details for Construction) to include updated sections and details reflecting Complete Streets concepts and policy in Howard County; repealing current Howard County Design Manual Volume III (Roads and Bridges); and generally related to Volume III and IV of the Design Manual.

Introduced and read first time Jan 4, 2022.

By order

Michelle Harrod  
Michelle Harrod, Administrator

Read for a second time at a public hearing on Jan 18, 2022.

By order

Michelle Harrod  
Michelle Harrod, Administrator

This Resolution was read the third time and was Adopted , Adopted with amendments , Failed , Withdrawn , by the County Council on Feb 7, 2022.

Certified By

Michelle Harrod  
Michelle Harrod, Administrator

Approved by the County Executive Feb 9, 2022

Calvin Ball  
Calvin Ball, County Executive

NOTE: [[text in brackets]] indicates deletions from existing law; TEXT IN SMALL CAPITALS indicates additions to existing law; ~~Strike-out~~ indicates material deleted by amendment; Underlining indicates material added by amendment

1           **WHEREAS**, in accordance with Section 18.210 of the Howard County Code, the Design  
2 Manual sets forth Howard County's technical standards for the design and construction of roads  
3 and utilities in Howard County; and

4           **WHEREAS**, the last comprehensive revision of the Design Manual, Volume III (Roads  
5 and Bridges) occurred in 2017 with the passage of Council Resolution No. 138-2017; and

6           **WHEREAS**, the last comprehensive revision of the Design Manual, Volume IV  
7 (Standard Specifications and Details for Construction) occurred in 2017 with the passage of  
8 Council Resolution No. 139-2017; and

9           **WHEREAS**, since the comprehensive revision, Council has adopted Council Resolution  
10 120-2019 calling for revisions that “develop a Complete Streets Design Manual that implements  
11 Complete Streets Policy”; and

12           **WHEREAS**, these design guidance revisions, combined with new processes for  
13 community engagement and project prioritization represent an updated approach to  
14 transportation in Howard County, intended to provide a more transparent and inclusive process  
15 and safer streets for everyone; and

16           **WHEREAS**, the goal of Complete Streets is to enhance, prioritize, and incentivize the  
17 utilization of a range of transportation options in Howard County, including walking, bicycling,  
18 transit use, and accessibility for all users to improve the health, wellbeing, and sustainability of  
19 Howard County; and

20           **WHEREAS**, The Office of Transportation appointed a Complete Streets Implementation  
21 Team (CSIT) pursuant to Council Resolution 120-2019; and

22           **WHEREAS**, the CSIT met 37 times since December 2019 and submitted a Draft  
23 Advisory Document for public review and comment between October 11 and October 28, 2021;  
24 and

25           **WHEREAS**, the Office of Transportation presented documents summarizing the changes  
26 to the Design Manual at two workshops in October 2021 and has posted those documents on its  
27 website, <https://www.howardcountymd.gov/DM-updates>, along with all responses to questions

1 received during the public comment period, and made changes in response to comments by both  
2 the public and the CSIT since the draft was published on October 11, 2021; and

3 **WHEREAS**, Howard County met with the CSIT on December 1, 2021 to finalize the  
4 version that has been posted on the Howard County Office of Transportation Website since  
5 December 7, 2021; and

6 **WHEREAS**, the Director of Public Works has proposed a comprehensive rewrite of  
7 Volume III (“Roads and Bridges”) to amend the content and change the name of the volume to  
8 be “Complete Streets and Bridges”, as shown in the attached Exhibit A; and

9 **WHEREAS**, the Director of Public Works has also proposed a revision to Volume IV of  
10 the Design Manual to update various detail drawings, as shown in the attached Exhibit B; and

11 **WHEREAS**, the proposed revisions were considered by the Howard County Public  
12 Works Board at its public hearings on November 9 and December 14, 2021 and the Board  
13 recommended submission of the updates to Volume III and IV of the Design Manual for  
14 consideration by County Council; and

15 **WHEREAS**, the proposed revisions were endorsed by the Howard County Multimodal  
16 Transportation Board at its December 16, 2021 meeting; and

17 **WHEREAS**, the proposed revision of Design Manual Volume III incorporates design  
18 guidance related to Complete Streets with a focus on safety for all road users and the proposed  
19 revision of Design Manual Volume IV incorporates changes to the detail drawings; and

20 ~~**WHEREAS**, the Administration will be convening a similar Complete Streets~~  
21 ~~Implementation Team in 2022 to assist in the development of revised transportation components~~  
22 ~~for proposed Subdivision and Land Use Regulations and related additional changes to the Design~~  
23 ~~Manual Volume III Chapters 4 and 5 that are needed to support the County’s Complete Streets~~  
24 ~~Policy.~~

25 **WHEREAS**, following the adoption of this resolution, the Administration shall convene  
26 a similar Complete Streets Implementation Team in 2022 to develop comprehensive changes to



1 the Design Manual Volume III Chapters 4 and 5 that are needed to support the County’s  
2 complete streets policy and inform revisions to the Subdivision and Land Use Regulations; and

3 WHEREAS, revisions to Adequate Public Facilities Ordinance and Subdivision and  
4 Land Use Regulations must reflect a complete streets approach throughout the County that  
5 would support and encourage walking, bicycling, transit use, and accessibility for all users as per  
6 the County’s Complete Streets Policy (CR 120-2019); and

7 WHEREAS, the Complete Streets Implementation Team shall make comprehensive  
8 revisions to Chapters 4 and 5 of the Design Manual Volume III and Subdivision and Land Use  
9 Regulations and submit an updated copy of the Design Manual Volume III to the County  
10 Council for approval nine months following the adoption of the Design Manual per the Complete  
11 Streets Policy (CR 120-2019); and

12 WHEREAS, the County Council strongly encourages that the Administration take a  
13 proactive approach to incorporate Complete Streets principles and transportation mode shift  
14 goals to increase active transportation and reduce road traffic through the ongoing “HoCo By  
15 Design” General Plan process and other planning efforts

16 **NOW, THEREFORE, BE IT RESOLVED** by the County Council of Howard County,  
17 Maryland this 7 day of February, 2022, that the Howard County Design Manual,  
18 Volume III (Roads and Bridges), previously adopted by Council Resolution No. 138-2017, is  
19 hereby repealed.

20 **AND BE IT FURTHER RESOLVED**, by the County Council of Howard County,  
21 Maryland that the Howard County Design Manual, Volume III is hereby renamed to be  
22 “Complete Streets and Bridges” and the revised Volume III, attached as Exhibit A, is hereby  
23 adopted as the Howard County Design Manual Volume III.

24 **AND BE IT FURTHER RESOLVED**, by the County Council of Howard County,  
25 Maryland that the Design Manual Volume IV, previously adopted by Council Resolution No.  
26 139-2017, is amended as follows, with all substitute and newly inserted pages show in Exhibit B:

27 The following Details are removed and substituted:

- 1           1. R-1.01 through R-1.09
- 2           2. R-2.01 and R-2.02
- 3           3. R-3.05
- 4           4. R-4.01 through R-4.06 and R-4.11
- 5           5. R-5.01 through R-5.06
- 6           6. R-6.01 through R-6.04; R-6.07 and R-6.10

7           The following new Details are being inserted:

- 8           1. R-1.10 through R-1.16;
- 9           2. R-4.08, R-4.09, R-4.10, R-4.12 and R-4.13;
- 10          3. R-6.11

BY THE COUNCIL

This Bill, having been approved by the Executive and returned to the Council, stands enacted on Feb 9, 2022.

Michelle Harrod  
Michelle Harrod, Administrator to the County Council

BY THE COUNCIL

This Bill, having been passed by the yeas and nays of two-thirds of the members of the Council notwithstanding the objections of the Executive, stands enacted on \_\_\_\_\_, 2022.

\_\_\_\_\_  
Michelle Harrod, Administrator to the County Council

BY THE COUNCIL

This Bill, having received neither the approval nor the disapproval of the Executive within ten days of its presentation, stands enacted on \_\_\_\_\_, 2022.

\_\_\_\_\_  
Michelle Harrod, Administrator to the County Council

BY THE COUNCIL

This Bill, not having been considered on final reading within the time required by Charter, stands failed for want of consideration on \_\_\_\_\_, 2022.

\_\_\_\_\_  
Michelle Harrod, Administrator to the County Council

BY THE COUNCIL

This Bill, having been disapproved by the Executive and having failed on passage upon consideration by the Council stands failed on \_\_\_\_\_, 2022.

\_\_\_\_\_  
Michelle Harrod, Administrator to the County Council

BY THE COUNCIL

This Bill, the withdrawal of which received a vote of two-thirds (2/3) of the members of the Council, is withdrawn from further consideration on \_\_\_\_\_, 2022.

\_\_\_\_\_  
Michelle Harrod, Administrator to the County Council

# HOWARD COUNTY



## VOLUME III DESIGN MANUAL

COMPLETE STREETS AND BRIDGES

**The Department of Public Works  
Bureau of Engineering  
Howard County, Maryland**

**HOWARD COUNTY DESIGN MANUAL  
VOLUME III  
COMPLETE STREETS AND BRIDGES**

**Howard County Council  
Resolution No. 17-2022, February 2022**

**HOWARD COUNTY DESIGN MANUAL**  
**VOLUME III**  
**COMPLETE STREETS AND BRIDGES**

- CHAPTER 1**      **Introduction and General Information**
- CHAPTER 2**      **Street Design**
- CHAPTER 3**      **Design of Bridges, Retaining Walls, and Small Structures**
- CHAPTER 4**      **Adequate Transportation Facilities Test Evaluation Requirements**
- CHAPTER 5**      **Multimodal Traffic Studies**

# CHAPTER 1

## Introduction and General Information

### 1.1 INTRODUCTION

- A. How to Use This Manual..... 1-1
- B. How This Manual Was Developed..... 1-1
- C. Complete Streets Policy..... 1-2
- D. Equity Emphasis Areas..... 1-3
- E. Authorization..... 1-3

### 1.2 PROJECT TYPES AND DELIVERY PROCESS

- A. Capital Projects..... 1-5
- B. Land Development Projects..... 1-5
- C. Project Prioritization for Capital Projects..... 1-6
- D. Community Engagement Plan..... 1-6
- E. Pedestrian and Bicycle Master Plans..... 1-7
- F. Exceptions..... 1-7

### 1.3 STREET TYPES

- A. Land Use Context..... 1-9
- B. Transportation Classification..... 1-9
- C. Street Types..... 1-10
- D. Scenic Roadways..... 1-24
- E. Retrofit Projects..... 1-25

### 1.4 ENGINEERING REPORTS

- A. Purpose of Report..... 1-28
- B. Content of Report..... 1-28
- C. Submission for Review..... 1-28
- D. Public Meetings..... 1-28

### 1.5 CONTROL, TOPOGRAPHIC AND CONSTRUCTION SURVEYS

- A. Control Surveys..... 1-29
- B. Topographic Surveys..... 1-29

### 1.6 PREPARATION OF CONSTRUCTION PLANS

- A. General..... 1-32
- B. Purpose..... 1-32
- C. Drafting and Graphic Standards..... 1-32
- D. Computer Applications..... 1-35
- E. Standards for Depicting Existing Conditions.. 1-35

### 1.7 PREPARATION OF CONSTRUCTION SPECIFICATIONS

- A. General..... 1-36
- B. Standard Format..... 1-36
- C. Special Provisions/Technical Specifications.. 1-36
- D. Proposals..... 1-36

### 1.8 RECORD DRAWINGS

- A. General..... 1-37
- B. Electronic Files..... 1-37
- C. Replacement Drawings..... 1-37

### 1.9 DEFINITIONS..... 1-38

### 1.10 ABBREVIATIONS..... 1-39

### 1.11 REFERENCES..... 1-40

## APPENDICES

- A. Highway Classification Characteristics
- B. Standard Reference Plan
- C. Howard County Complete Streets Policy
- D. Community Engagement Plan
- E. Transportation Classification Map
- F. Street Type – Functional Classification Correlation Chart

## 1.1 Introduction

### A. How to Use This Manual

The purpose of the Howard County Complete Streets Design Manual is to provide criteria and guidance for the design of a safe, efficient, and comfortable transportation network for all modes of travel.

The fundamental design principle for transportation facilities is Complete Streets, or streets that are safe, comfortable, and convenient for people of all ages and abilities, whether they are walking, bicycling, riding transit, or driving.

The guidance contained in this manual is compatible with that of the American Association of State Highway and Transportation Officials (AASHTO) and the Maryland Department of Transportation State Highway Administration (MDOT SHA). References are made to documents and criteria published by these and other agencies where appropriate. This manual is a supplement to those documents and is intended to substantially conform to their criteria. However, where differences exist, this manual shall govern.

The engineering requirements included in this manual are intended to guide land developers and Designers in the design and construction of transportation facilities within Howard County. Both Capital Projects and Land Development Projects, defined in this chapter, must conform to the procedures, requirements and criteria set forth in this manual. Allowable exceptions, and procedures for obtaining approval of those exceptions, are described in Section 1.2.E.

The manual is not intended to restrict the Designer's opportunity to create innovative and practical designs for transportation improvements. Rather, it is intended to assist the Designer in completing the projects efficiently and economically in a manner that supports safety, quality of life, equity, economic sustainability, and the environment. In particular, the Designer should look for additional opportunities to improve safety and comfort for vulnerable travelers such as pedestrians and bicyclists.

### B. How This Manual Was Developed

The Howard County Complete Streets policy, described and included as an appendix to this chapter, established a Complete Streets Implementation Team (CSIT) composed of an equal number of County staff and external stakeholders. Updates to the Design Manual to incorporate the provisions of the Complete Streets policy were required by the policy and were undertaken by staff of the Department of Public Works (DPW), the Office of Transportation (OOT), and the Department of Planning and Zoning (DPZ) in collaboration with the CSIT. The goal of this process was to ensure the Design Manual fully addresses all modes of travel. Accordingly, street design criteria and processes in the Manual are based on national best practices.

The Design Manual reflects input from technical experts, stakeholders, and the broader community. CSIT meetings were open to the general public, and meeting materials and minutes were posted to the CSIT website for public review. Public workshops were held on October 14 and 21, 2021 to generate input. Throughout the revision process, close to 1,000 comments on the draft Design Manual were submitted by members of the CSIT, transportation professionals, advocates, and other members of the public. All the comments were considered for the submitted Design Manual. The draft Complete Streets Design Manual was also reviewed through a public process with the Public Works Board, the Multimodal Transportation Board and County Council.



### C. Complete Streets Policy

The Howard County Complete Streets policy was adopted by County Council through Resolution 120-2019 on October 7, 2019. Portions of the policy have been included below since they are fundamental principles for the Design Manual.

#### 1. Vision

The Complete Streets policy includes the following vision:

“To ensure that Howard County is a place for individuals of all backgrounds to live and travel freely, safely, and comfortably, public and private roadways in Howard County shall be safe and convenient for residents of all ages and abilities who travel by foot, bicycle, public transportation or automobile, ensuring sustainable communities Countywide.” – Council Resolution 35-2016

Volume III of the County Design Manual has been revised in support of this vision.

#### 2. Benefits

- **Safety:** fewer and less severe crashes for everyone using the street
- **Equity:** assurance that transportation projects properly serve the communities they are designed for, especially traditionally disenfranchised communities
- **Health:** greater opportunities for exercise, more independent travel for children, and more chances for older adults to stay active in their communities
- **The economy:** jobs, reduced retail vacancies, increased property values, and less household income spent on transportation
- **Quality of life**

#### 3. Speed Management and Safety as a Priority

The Complete Streets policy includes the following statement regarding conflicting and competing needs between modes of travel:

“When there are conflicting needs among users and/or modes, safety shall be the highest priority; particularly safety for the most vulnerable street users (pedestrians, bicyclists, children, seniors, and people with additional accessibility needs). Selection and quantitative weighting of performance measures shall also support investment in the most underinvested and underserved communities.

Motor vehicle speed, flow, and driver convenience shall not be prioritized over safety for vulnerable street users. Reducing excessive motor vehicle speeds on streets where vulnerable users are likely will be considered a net benefit to the community.

To the extent that current code allows, when space is a limiting factor and where vulnerable users are likely, allocating space to a mode that is not currently accommodated shall be prioritized over providing additional space to a mode that is already accommodated.”

## D. Equity Emphasis Areas

Equity is at the center of transportation decision making in Howard County. To ensure resources are directed toward traditionally underserved communities and those with the greatest need, the County evaluated Equity Emphasis Areas (EEA) using U.S. Census Bureau data to measure the percentages of the following population groups in each census tract:

- Low-income: as measured by the U.S. Census as “population in poverty,” which is defined by a set of income thresholds that vary by household size and composition
- Hispanic: as defined by the U.S. Census as a person of Mexican, Puerto Rican, Cuban, Central or South American, or other Spanish culture or origin, regardless of race
- Non-Hispanic, Non-White: “non-white” or “minority” is defined by the U.S. Department of Transportation Order (5610.2) on Environmental Justice as Black, Asian American, Native Hawaiian or Pacific Islander, American Indian and Alaskan Native, some other race alone, and two or more races
- Limited English Proficiency (LEP): as defined by the U.S. Census as people aged 5 and over who speak a foreign language at home and either speak no English or speak English “not well”
- Persons with disabilities: as measured by the U.S. Census as “disabled,” and defined by a person of any age whose hearing, vision, cognition or ambulation difficulties result in limitations of activities and restrictions to full participation at school, work, home, or in the community
- Older adults: as measured by the U.S. Census as “elderly,” and defined by a person age 75 and above
- Carless: as defined by the U.S. Census as a household with no vehicles available

When the percent of the seven population groups in each census tract is higher than the County mean, this tract is counted as an emphasis area. Tracts with even greater disparity receive additional weight. Data from each group is combined to create a composite score to measure the degree to which each tract is emphasized. This system is used in the project prioritization process, whereby priority is be given to census tracts with higher EEA scores.

The assessment shown on the following page uses American Community Survey data from 2015 five-year data. The map in this chapter is simply an illustration. A more detailed interactive EEA map, which is updated periodically as the United States Census releases new data, is available on the Howard County website for reference.

The EEA is also used to identify which population groups live near a proposed transportation improvement. Engaging with EEA populations is specified more fully in the Community Engagement Plan described in Section 1.2.D.

## E. Authorization

The Complete Streets Design Manual is Volume III of four volumes of the Howard County Design Manual authorized and required to be promulgated under the Howard County Subdivision and Land Development Regulations as formulated in Council Bill Number 41, enacted November 24, 1975, with periodic updates as approved by Howard County Council. The other volumes so authorized are:

- Volume I, Storm Drainage Design Manual
- Volume II, Water and Sewer Design Manual
- Volume IV, Standard Specifications and Details for Construction

All of these volumes may be accessed on the Howard County website.

The Design Manual is to provide "... the master technical standards required by Howard County for design, construction and inspection ..." of various public facilities. Although the Design Manual is mandated through the Subdivision and Land Development Regulations, it is nonetheless applicable to all other public works projects undertaken by the County.

Figure 1-1. Equity Emphasis Areas.

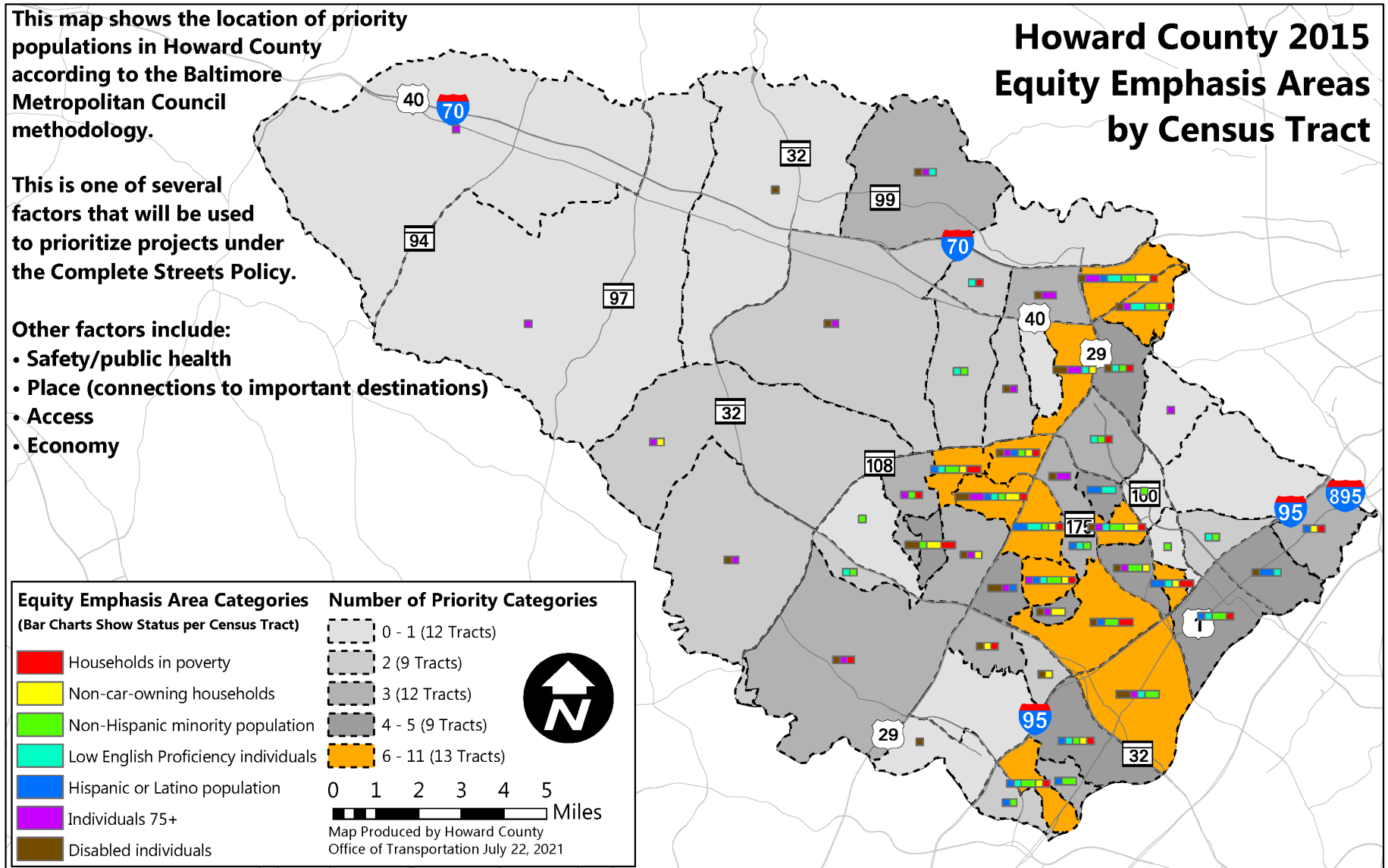

Note: This map is simply an illustration. A more detailed interactive EEA map, which is updated periodically as the United States Census releases new data, is available on the Howard County Interactive Map for reference.

## 1.2 Project Types and Delivery Process

Transportation projects in Howard County consist of two basic categories: Capital Projects and Land Development Projects. Funding for Capital Projects comes from the County's capital budget, while Land Development Projects are funded by the developer, which is often a private entity.

### A. Capital Projects

In Howard County, Capital Projects have traditionally been initiated in several ways. Residents may petition the County to undertake projects or to advance projects previously contemplated. Petitions for transportation projects are received by DPW, reviewed by DPW staff and endorsed with its recommendations, then forwarded to the Director of DPW. DPW may originate projects to alleviate existing or projected problems in the overall operation of transportation facilities. The County Council may ask the County Executive to create a Capital Project.

Regardless of who or what the originating cause is for a Capital Project, the County Executive is charged with the responsibility of annually preparing a budget of Capital Projects for adoption by the County Council.

As required by County Charter, public hearings are held prior to action by the Council. This is done for the purpose of reviewing the proposed budget items, publicly displaying all proposals for Capital Projects, and receiving citizen comments.

County Staff within DPW, often in coordination with the transportation planning staff with OOT, accomplish most of the preliminary work associated with the identification of Capital Projects. However, after the adoption and funding of Capital Projects are approved, it is normal practice for the County to engage the services of consulting engineers (designers) to provide the detailed engineering for transportation projects. Selection of a Designer is made in accordance with County regulations and policies.

Contracts with Designers on transportation projects shall stipulate the scope of work, schedule to be followed and arrangements and other details normally associated with contractual procedures. Changes in the Designer's scope of work shall be through a

change order to the engineering agreement. Unless otherwise accepted by contract, the Designer for Capital Projects shall advance a project in the same general manner as described for Developer Projects. All submissions of reports, plans and specifications shall be made directly to DPW.

The Designer shall begin the project by preparing a concise report of the project describing the purpose and extent of the work, providing a preliminary cost estimate and other items of an engineering nature. Review and approval routines as described in this manual shall be followed. When engaged in a Capital Project, the Designer's point of contact is with DPW or OOT, depending on the lead department for the project. DPW or OOT shall designate a Project Manager from its staff who shall assume responsibility for monitoring the project, coordinating details and reviewing reports, plans, specifications and other data to ensure that the engineering work satisfies the project requirements.

### B. Land Development Projects

A Land Development Project arises whenever a land developer engages in the subdivision of land or the development of a parcel of land, either of which fall under the requirements of the Subdivision and Land Development Regulations. When this is the case, the developer shall be required to completely underwrite the cost of construction of these facilities and shall prepare an engineering report, construction plans and specifications, easement documents, and stakeout and inspection of the construction work. A Developer Project is represented by a signed contract called a Developer Agreement between the developer and the County.

If the project meets the basic requirements of the Subdivision and Land Development Regulations, DPZ shall indicate to the developer the financial requirements that the developer must satisfy in order to continue with the project. If required by DPW, the developer may advance the project by developing an engineering report addressing the considerations set forth in the following chapters of this manual. The report shall be used as the basis for a Developer Agreement, which includes the financial arrangements for both engineering design and construction costs.

Upon the receipt and approval of the engineering report and the preliminary roadway plan, the engineering design of construction plans is authorized.

These plans are advanced to the preliminary plan level of completion at which time they are submitted for review to DPZ, together with a construction cost estimate. The plans are then brought to completion and resubmitted to DPZ for final review and approval. After approval by DPZ, and in coordination with other approvals under the subdivision regulations and Section 16.121 of the Howard County Code, the project may advance to the construction phase. The final action under the Developer Agreement is the financial settlement between the County and the developer in accordance with the terms of the Developer Agreement.

### C. Project Prioritization for Capital Projects

The adoption of the Complete Streets policy required Howard County to develop a project scoring mechanism for all potential capital transportation projects based on a subset of the performance measures mentioned in the policy. The intent of project prioritization is to develop a more consistent and transparent method for advancing transportation projects when funding is available to do so.

This prioritization process is called the Transportation Improvement Prioritization System (TIPS). TIPS is designed to give an objective measure of the anticipated benefits of transportation projects as they are considered for inclusion in the capital budget. Under TIPS, candidate transportation improvements are scored using four primary categories: (1) multimodal safety and access, (2) equity, (3) crash history, and (4) system preservation/maintenance. Bonus points are provided for those projects that leverage funding from non-County sources. Up to one third of the highest-scoring projects are ranked as High Priority, up to one third as Medium Priority, and the remainder as Low Priority. Those priority levels do not form the entire decision-making process; rather, they inform the decision-making process. The County Executive may determine that there needs to be a more diverse spread of projects in terms of cost, need, significant and unique funding opportunity, geographic location, or to address a significant and immediate safety need in any given fiscal year.

### D. Community Engagement Plan

Equitable community engagement is essential to the success of Complete Streets, particularly in the planning and design phases when decisions are being made. Howard County's goal for community engagement is to enable people who are affected by transportation projects, particularly groups that have been historically disinvested, to play a meaningful role in the planning and decisions about transportation projects that impact their lives. Striving for equity in engagement requires acknowledging that everyone does not start at the same place, and some people may need different resources to meaningfully participate in the transportation planning process. Howard County staff should take every opportunity to create positive relationships with all members of the community affected by a transportation project.

The Community Engagement Plan (CEP) presents a public involvement approach for transportation projects, as required by the Howard County Complete Streets policy. It is intended to illustrate procedures for how Howard County employees and others involved in development of transportation projects will engage with the general public in the transportation project development process. Engagement checklists for various types of projects are provided for the use of County Project Managers.

The purpose of the CEP is to give a voice to community members affected by transportation projects, especially those who may have been disenfranchised from participating in the civic process. To that end, the CEP is intended to advance the following goals:

- **Engagement:** Build relationships with community institutions representing community stakeholders to yield diverse public engagement with project development
- **Communications:** Increase awareness about Complete Streets and transportation projects among community stakeholders
- **Equitable Access:** Provide multiple options and formats for public engagement that encourage meaningful interaction and collaboration between Howard County staff and community stakeholders
- **Process and Outcomes:** Formalize internal processes, internal and external feedback loops, and ongoing community engagement

Community engagement is not only important for its own sake. When done correctly, it helps create public support for projects. Public support, especially when gained early in the project development process, tends to result in fewer community-driven changes during design, keeping projects on schedule and within budget.

The CEP contains the following information:

- **What is community engagement?** This section provides background on the Howard County Complete Streets policy, explains what community engagement is, and lists the public entities who are involved with the transportation decision making process.
- **Why is engagement important?** This section sets out the vision and guiding principles that guide the County's community engagement process and why engagement is important. It also sets out the goals for the process, along with objectives and performance measures that will be used to gauge the County's success in achieving those goals.
- **Who is the community?** This section defines what community means in the context of the community engagement process. It explains the importance of striving for diversity, equity, and inclusion throughout engagement, and explains how to identify the community stakeholders.
- **How do we engage the community?** This section outlines methods of communicating with the community as well as tools that will be used to interact with the community and collect public feedback.
- **How do we make decisions?** This section outlines a typical project development process and highlights the decision points where community input is critical. It suggests what tools may make sense to use during different steps of the process. County staff is responsible for making the final decision about a design after considering public feedback and technical analysis.
- **Citizen's Guide to Community Engagement:** This section provides a guide for residents and other stakeholders to engage with Howard County transportation projects.

The full CEP is included as an appendix.

## E. Pedestrian and Bicycle Master Plans

The primary purpose of Howard County's pedestrian and bicycle master plans is to provide a framework for improving conditions for people walking and bicycling in Howard County and promoting both modes as safe and convenient travel options (Ref. 1, Ref.2). Each document provides recommendations in the following categories:

- Policy
- Program
- Facility and network

Because the pedestrian and bicycle master plans include specific recommendations to promote walking and bicycling networks, Designers shall familiarize themselves with these plans and incorporate relevant recommendations into their projects. This Design Manual provides detailed design guidance for pedestrian and bicycle facilities that supports the stated goals of each master plan.

Further guidance on pedestrian facilities is provided by the "Guide for Planning, Design, and Operation of Pedestrian Facilities" (AASHTO, Ref. 3). This design manual incorporates treatment types recommended in the Bicycle Master Plan.

Further guidance on bicycle facilities is provided by the "Guide for the Development of Bicycle Facilities" (AASHTO, Ref. 4), the "Urban Bikeway Design Guide," National Association of City Transportation Officials (NACTO, Ref. 5), and the "Manual on Uniform Traffic Control Devices" (FHWA, Ref. 6).

Additional details on bicycle and pedestrian facility types are provided in Chapter 2.

The implementation of walking and bicycling infrastructure requires working with developers on land development projects and with County staff on capital projects as described in section 1.2.A and 1.2.B.

## F. Exceptions

Cases for exceptions and the process for reviewing exceptions are specified in the Complete Streets policy and are more fully described below.

Complete Streets improvements may not be appropriate in some cases due to the context. There are different exception processes for Capital Projects and Developer Projects.

For capital projects within the scope of the Complete Streets policy, the Designer must apply to the County for an exception to the design requirements. A request for an exception is to be addressed to the Chief of the Bureau of Engineering and shall, at a minimum, contain a narrative indicating the design objective and the justification for the request. Exceptions shall be reviewed and approved unanimously by the Director of Public Works, the Director of Planning and Zoning, and the Administrator of the Office of Transportation or their designees. When an exception is being considered for a particular capital project, public notice, including a description of the project and the reason for the exception, shall be given through the Office of Transportation website. The Multimodal Transportation Board shall be given the opportunity to offer an advisory opinion before an exception is granted.

For development projects, exceptions shall be considered using the development review process as specified in the Subdivision and Land Development Regulations, which provides opportunities for technical review and public input.

Exceptions may be considered for approval when the project (either capital or developer) involves:

1. An accommodation that is not necessary on corridors where specific user groups are prohibited;
2. A justifiable absence of current and future need exists and is not recommended in any existing planning documents;
3. A project of equivalent scope and schedule exists or is already programmed for funding within the next five years to provide connectivity for all users; or
4. Cost of accommodation or degree of impact is grossly disproportionate to the need or probable use.

## 1.3 Street Types

Well-designed streets take into account both the land use context in which they are located and the transportation function they are designed to serve. The combination of the two creates a street “typology,” or a compilation of street types. The design controls and criteria in Chapter 2 are based on the street types in the typology.

### A. Land Use Context

Four general land use contexts were generated based on the County’s Land Use Map, Zoning Map, and Designated Place Types from the Howard County General Plan. This map specifies four land use contexts as follows:

- Mixed use
- Suburban
- Industrial
- Rural

It is the responsibility of the Designer to identify the future land use context of the area based on the “Howard County General Plan” (Ref. 7). This will allow for selection of an appropriate street type to address future needs.

### B. Transportation Classification

Streets provide the basic transportation functions of facilitating mobility and providing access to adjacent properties. The following five classifications reflect the extent to which each of those two functions are served. These classifications are historically based on a hierarchy from the Federal Highway Administration and are primarily focused on motor vehicle throughput. Although these classifications remain in use for other purposes, street design is based on the multimodal street types in Section 1.3.C.

#### Principal Arterial (Freeway)

Principal arterials provide for efficient and uninterrupted travel between or across states and large metropolitan areas. Principal arterials include most interstate designated routes. All principal arterials in Howard County are State-maintained roads, for which MDOT SHA design guidance must be used (Ref. 8, Ref. 9). Therefore, principal arterials are not included in the typology in Section 1.3.C.

#### Intermediate Arterial

Intermediate arterials generally provide access to principal arterial highway, offering efficient but not necessarily free or uninterrupted motor vehicle traffic flow between major roads in highly developed areas. Like principal arterials, their primary function is motor vehicle through traffic.

#### Minor Arterial

Minor arterials provide a lower level of travel mobility than intermediate arterials to major towns and communities. They often provide mobility to or through area of high density residential, commercial, retail, or industrial land uses. Unlike principal and intermediate arterials, minor arterials may allow occasional access to abutting commercial, residential and industrial properties at predetermined locations. However, their primary function is for motor vehicle through traffic.

#### Collector

Collectors provide connections between mobility-oriented arterials and access-oriented local streets. They may allow a limited amount of travel through neighborhoods and non-residential areas, even when that travel does not begin or end in the neighborhood. There are two types of collectors: major and minor. Driveway access to adjacent properties is generally allowed on minor collectors but not major collectors.

#### Local Street

Local streets are focused on access to adjacent properties, allowing direct driveway access. They are generally not designed to accommodate motor vehicle through traffic, except to connect other local streets with a nearby collector.

Each street in Howard County has one of these classifications. They are defined in the Transportation Classification Map in the appendix to this chapter. Street types as defined in the next section are not always directly linked to transportation classification, but rather to the future land use context and anticipated future multimodal needs of the street. Selection of a street type for a project is described in the following section.



Although the street design guidance in this Design Manual is not applicable to State roadways, the Complete Streets policy states that “the County shall work proactively with the State of Maryland, neighboring communities and counties, and businesses and educational institutions to develop plans, facilities, and accommodations that further the County’s Complete Streets policy.” For capital projects that involve State roadways, the Designer shall work with MDOT SHA to incorporate the Complete Streets provisions of this Manual to the extent that MDOT SHA is able to do so.

### C. Street Types

Using land use contexts described in Section 1.3.A and anticipated vehicular volume, the Designer may identify the appropriate street type based on Table 1-13. Design controls and criteria for each street type are found in Chapter 2. For design controls and criteria which are related to functional classification, and where a functional classification has not yet been assigned to a new street, refer to Appendix E of this chapter to select the functional classification based on the street type.

For new construction projects, the appropriate street type can be designed based on the construction details provided in Volume IV. For retrofit projects, the street types function as a starting point for the Designer. See Section 1.3.E for more information on retrofit projects.

Street types were developed by linking land use contexts common to Howard County with accommodations for all modes of travel. Three guiding principles were used in the development of typical sections for each street type.

- People walking will have sidewalks or shared use paths in any street types where there is significant demand for walking.
- People bicycling will have bicycle facilities that operate at a Level of Traffic Stress (LTS) of 2 or better. LTS, described in detail in Chapter 5, is a measure of comfort for bicyclists (Ref. 10). As illustrated in Chapter 2, there are some areas where a higher standard of LTS 1 is appropriate.
- People driving will have sufficient space to travel at reasonable speeds that foster the safety, convenience, and comfort of all users of the street. As described in Section 1.1.C.3, “Motor vehicle speed, flow, and driver convenience shall not be prioritized over safety for vulnerable street users” such as people walking and bicycling.
- Street trees remain a desirable characteristic along County roads of all types. In circumstances where trees are not provided in the six-foot tree/buffer zone within the right of way, the Designer should incorporate tree plantings where feasible along the right of way length, within landscape buffer areas, and as stand-alone curb extensions where width and circumstances permit.

## Boulevard

The Boulevard street type is intended for high volume, higher density mixed-use areas. Volumes of people walking and riding bicycles and other micro-mobility devices like scooters are anticipated to be high due to dense residential and commercial development. Therefore, separate walking and bicycling facilities are required instead of a shared use path. Due to anticipated high parking turnover and high motor vehicle volumes, a separated bike lane is recommended instead of an unprotected on-street bike lane. While only about five feet of the sidewalk is located within the public right of way, developers can accommodate other on street amenities like restaurant seating within a privately owned frontage zone.

### Features:

- Mixed-use/higher density areas
- Four-lane divided street
- Grass or landscaped median/center turn lane
- Separated bikeways
- Sidewalks
- Privately owned frontage zone for additional street furniture and restaurant seating
- Options with and without parking

Figure 1-2. Boulevard.



TABLE 1-1. BOULEVARD DIMENSIONS AND CHARACTERISTICS

Street Type	Right of Way Width	Center Turn Lane/Median	Inside Travel Lane*	Outside Travel Lane	Shoulder/Offset from Curb	Parallel Parking	On-Street Bike Lane	Buffer Zone***	Separate Bike Lane	Sidewalk	Shared Use Path	Target Speed	Carrying Capacity
Boulevard	116'	11' **/ 16'	11' **	11'	N/A	8' **	N/A	6'	6.5'	5' min (2 sides)	N/A	25 mph	35-40k
Boulevard No Parking	100'	11' **/ 16'	11' **	11' **	N/A	N/A	N/A	6'	6.5'	5' min (2 sides)	N/A	25 mph	35-40k

\*Against center line/median; \*\* Includes 1' gutter pan; \*\*\*Dimension measured from back of curb to sidewalk/separated bike lane/shared use path

## Town Center Connector

The Town Center Connector street type is intended for moderate volume, higher density mixed-use areas. Volumes of people walking and riding bicycles and other micro-mobility devices like scooters are anticipated to be high due to dense residential and commercial development. Therefore, separate walking and bicycling facilities are required instead of a shared use path. Due to anticipated high parking turnover and moderate motor vehicle volumes, a separated bike lane is recommended instead of an unprotected on-street bike lane. While only about five feet of the sidewalk is located within the public right of way, developers can accommodate other on street amenities like restaurant seating within a privately owned frontage zone. When midblock pedestrian crossings are provided, curb extensions and median refuges should be provided to enhance pedestrian safety.

### Features:

- Mixed-use/higher density areas
- Three-lane street
- Center turn lane
- Separated bikeways
- Sidewalks
- Privately owned frontage zone for additional street furniture and restaurant seating
- Options with and without parking

Figure 1-3. Town Center Connector.



TABLE 1-2. TOWN CENTER CONNECTOR DIMENSIONS AND CHARACTERISTICS

Street Type	Right of Way Width	Center Turn Lane/Median	Inside Travel Lane*	Outside Travel Lane	Shoulder/Offset from Curb	Parallel Parking	On-Street Bike Lane	Buffer Zone**	Separate Bike Lane	Sidewalk	Shared Use Path	Target Speed	Carrying Capacity
Town Center Connector	88'	11'	N/A	11'	N/A	8' **	N/A	6'	6.5'	5' min (2 sides)	N/A	25 mph	<20k
Town Center Connector No Parking	72'	11'	N/A	11' **	N/A	N/A	N/A	6'	6.5'	5' min (2 sides)	N/A	25 mph	<20k

\*Against center line/median; \*\* Includes 1' gutter pan; \*\*\*Dimension measured from back of curb to sidewalk/separated bike lane/shared use path

## Town Center Street

The Town Center Street type is intended for moderate volume, higher density mixed-use areas. Volumes of people walking and riding bicycles and other micro-mobility devices like scooters are anticipated to be high due to dense residential and commercial development. Therefore, separate walking and bicycling facilities are required instead of a shared use path. Due to anticipated high parking turnover, a separated bike lane is recommended instead of an unprotected on-street bike lane. While only about five feet of the sidewalk is located within the public right of way, developers can accommodate other on street amenities like restaurant seating within a privately owned frontage zone. When midblock pedestrian crossings are provided, curb extensions and median refuges should be provided to enhance pedestrian safety.

### Features:

- Mixed-use/higher density areas
- Two-lane street
- Separated bikeways
- Sidewalks
- Privately owned frontage zone for additional street furniture and restaurant seating
- Options with and without parking

Figure 1-4. Town Center Street.

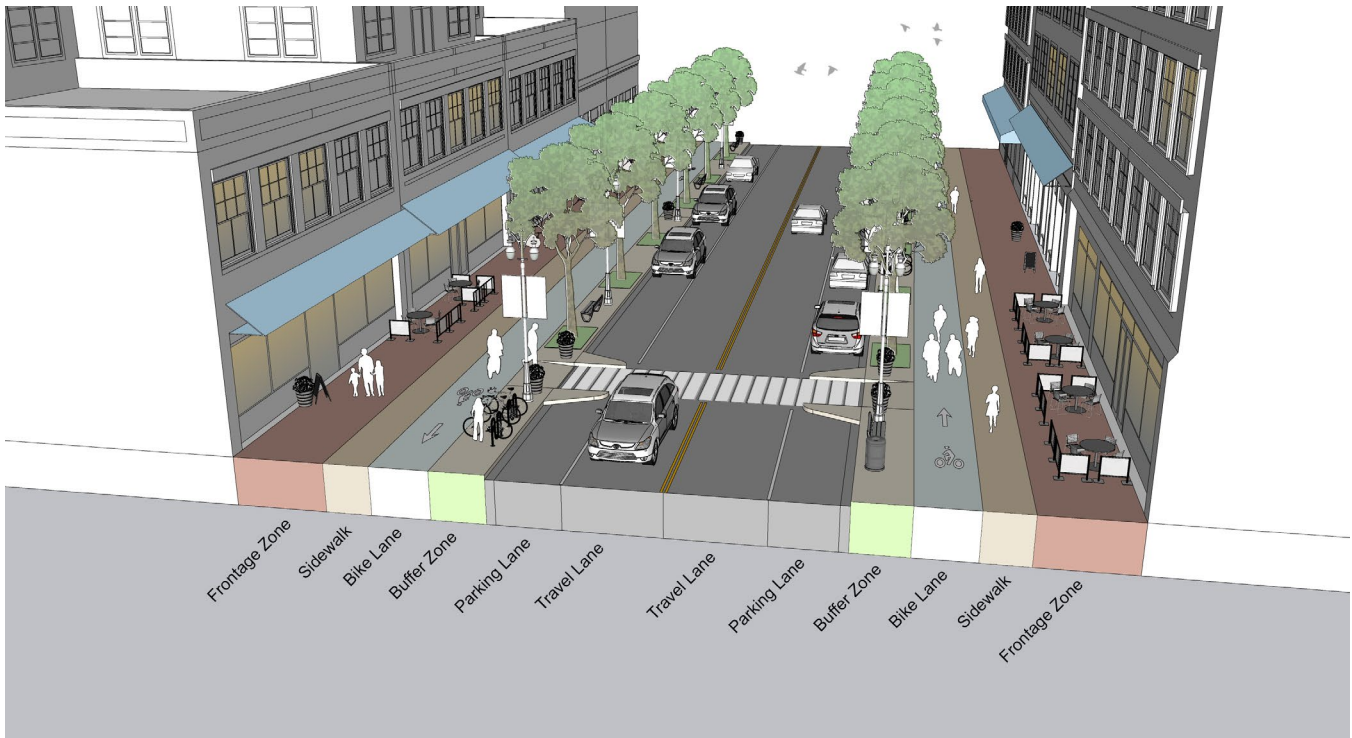

TABLE 1-3. TOWN CENTER STREET DIMENSIONS AND CHARACTERISTICS

Street Type	Right of Way Width	Center Turn Lane/Median	Inside Travel Lane*	Outside Travel Lane	Shoulder/Offset from Curb	Parallel Parking	On-Street Bike Lane	Buffer Zone***	Separate Bike Lane	Sidewalk	Shared Use Path	Target Speed	Carrying Capacity
Town Center Street	76'	N/A	N/A	10.5'	N/A	8' **	N/A	6'	6.5'	5' min (2 sides)	N/A	25 mph	<12k
Town Center Street No Parking	64'	N/A	N/A	12' **	N/A	N/A	N/A	6'	6.5'	5' min (2 sides)	N/A	25 mph	<12k

\*Against center line/median; \*\* Includes 1' gutter pan; \*\*\*Dimension measured from back of curb to sidewalk/separated bike lane/shared use path



# Parkway

The Parkway street type is intended for lower density suburban areas. Volumes of people walking and riding bicycles and other micro-mobility devices like scooters are anticipated to be lower since residential and commercial development is less dense. Therefore, a shared use path is required instead of separate bicycle and pedestrian facilities. A six foot tree zone will separate path users from high motor vehicle volumes and speeds. Due to infrequent crossing opportunities and the width of the roadway, a path is required on both sides of the street.

## Features:

- Suburban/lower density areas
- Four or six-lane divided street
- Grass or landscaped median/center turn lane
- Shared use paths
- No parking

Figure 1-5. Parkway.



TABLE 1-4. PARKWAY DIMENSIONS AND CHARACTERISTICS

Street Type	Right of Way Width	Center Turn Lane/Median	Inside Travel Lane*	Outside Travel Lane	Shoulder/Offset from Curb	Parallel Parking	On-Street Bike Lane	Buffer Zone***	Separate Bike Lane	Sidewalk	Shared Use Path	Target Speed	Carrying Capacity
Parkway (6-lane)	122'	11' **/ 16' min	12' **	11'	1'	N/A	N/A	6'	N/A	N/A	10' (2 sides)	varies	50-60k
Parkway (4-lane)	112'	11' **/ 28'	12' **	11'	1'	N/A	N/A	6'	N/A	N/A	10' (2 sides)	varies	50-60k

\*Against center line/median; \*\* Includes 1' gutter pan; \*\*\*Dimension measured from back of curb to sidewalk/separated bike lane/shared use path

## Neighborhood Connector

The Neighborhood Connector street type is intended for lower density suburban areas and will typically have consolidated or infrequent motor vehicle access points. Volumes of people walking and riding bicycles and other micro-mobility devices like scooters are anticipated to be lower since residential and commercial development is less dense. Therefore, a shared use path is required instead of separate bicycle and pedestrian facilities. A six foot tree zone will separate path users from moderate motor vehicle volumes and higher speeds (30 mph). Due to infrequent crossings and the width of the roadway, a path is required on both sides of the street. When midblock pedestrian crossings are provided, curb extensions and median refuges should be provided to enhance pedestrian safety.

### Features:

- Suburban/lower density areas
- Three-lane street
- Grass or landscaped median/center turn lane
- Shared use paths
- No sidewalks
- Options with and without parking

Figure 1-6. Neighborhood Connector.



TABLE 1-5. NEIGHBORHOOD CONNECTOR DIMENSIONS AND CHARACTERISTICS

Street Type	Right of Way Width	Center Turn Lane/Median	Inside Travel Lane*	Outside Travel Lane	Shoulder/Offset from Curb	Parallel Parking	On-Street Bike Lane	Buffer Zone**	Separate Bike Lane	Sidewalk	Shared Use Path	Target Speed	Carrying Capacity
Neighborhood Connector	86'	11'/9'	N/A	11'/12' ** at median	N/A	8' **	N/A	6'	N/A	N/A	10' (2 sides)	30 mph	<20k
Neighborhood Connector No Parking	70'	11'/9'	N/A	11' **/12' ** at median	N/A	N/A	N/A	6'	N/A	N/A	10' (2 sides)	30 mph	<20k

\*Against center line/median; \*\* Includes 1' gutter pan; \*\*\*Dimension measured from back of curb to sidewalk/separated bike lane/shared use path

## Neighborhood Street 1

The Neighborhood Street 1 street type is intended for lower density suburban areas. Volumes of people walking and riding bicycles and other micro-mobility devices like scooters are anticipated to be lower since residential and commercial development is less dense. Due to anticipated low motor vehicle volumes and low speeds (less than 35 mph), a buffered on-street bike lane is recommended instead of a shared use path. Sidewalks on both sides of the street provide adequate space for people walking, and for young children to ride bicycles.

### Features:

- Suburban/lower density areas
- Two-lane street
- On-road buffered bike lanes
- Sidewalks
- Options with and without parking

Figure 1-7. Neighborhood Street 1.

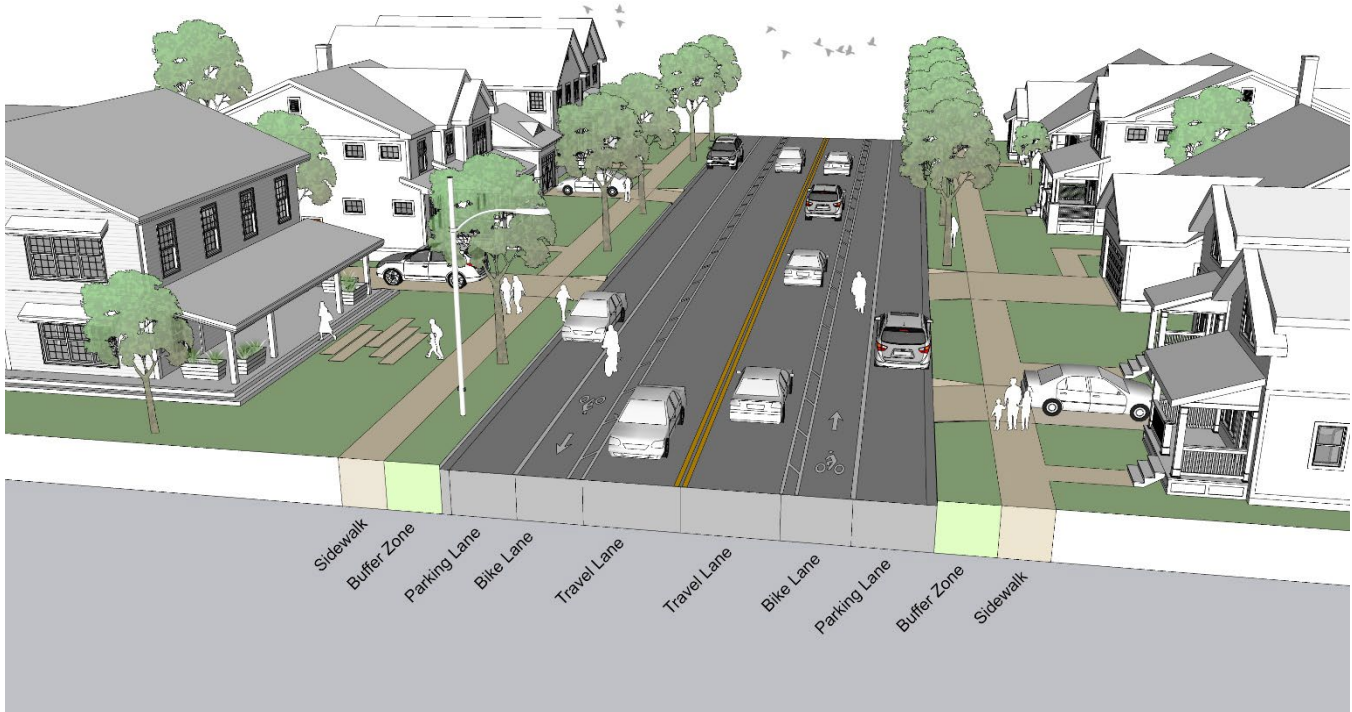

TABLE 1-6. NEIGHBORHOOD STREET 1 DIMENSIONS AND CHARACTERISTICS

Street Type	Right of Way Width	Center Turn Lane/Median	Inside Travel Lane*	Outside Travel Lane	Shoulder/Offset from Curb	Parallel Parking	On-Street Bike Lane	Buffer Zone***	Separate Bike Lane	Sidewalk	Shared Use Path	Target Speed	Carrying Capacity
Neighborhood Street 1	76'	N/A	N/A	10'	N/A	8' **	5' lane 2' buffer	6'	N/A	5' min (2 sides)	N/A	25 mph	<12k
Neighborhood Street 1 No Parking	62'	N/A	N/A	10'	N/A	N/A	6' ** lane 2' buffer	6'	N/A	5' min (2 sides)	N/A	25 mph	<12k

\*Against center line/median; \*\* Includes 1' gutter pan; \*\*\*Dimension measured from back of curb to sidewalk/separated bike lane/shared use path



## Neighborhood Street 2

The Neighborhood Street 2 street type is intended for lower density suburban areas. Volumes of people walking and riding bicycles and other micro-mobility devices like scooters are anticipated to be low due to lower density residential and commercial development. A shared use path is recommended on one side of the street, and a sidewalk on the other. This street type may be selected over Neighborhood Street Type 1 if there are local destinations that a child may need to access by bicycle such as an elementary school or library or if higher motor vehicle speeds are anticipated. Centerline markings are optional for this street type when parking is not provided, in accordance with the MdMUTCD.

### Features:

- Suburban/lower density areas
- Two-lane street
- Shared use path on one side of the street
- Sidewalk on the other side of the street
- Options with and without parking

Figure 1-8. Neighborhood Street 2.



TABLE 1-7. NEIGHBORHOOD STREET 2 DIMENSIONS AND CHARACTERISTICS

Street Type	Right of Way Width	Center Turn Lane/Median	Inside Travel Lane*	Outside Travel Lane	Shoulder/Offset from Curb	Parallel Parking	On-Street Bike Lane	Buffer Zone***	Separate Bike Lane	Sidewalk	Shared Use Path	Target Speed	Carrying Capacity
Neighborhood Street 2	74'	N/A	N/A	10.5'	N/A	8' **	N/A	6'	N/A	5' (1 side)	10' (1 side)	25 mph	<12k
Neighborhood Street 2 No Parking	60'	N/A	N/A	12' **	N/A	N/A	N/A	6'	N/A	5' (1 side)	10' (1 side)	25 mph	<12k

\*Against center line/median; \*\* Includes 1' gutter pan; \*\*\*Dimension measured from back of curb to sidewalk/separated bike lane/shared use path



## Neighborhood Yield Street

The Neighborhood Yield Street type is a local street type intended for moderate and lower density residential areas. On-street parking effectively narrows the roadway, which requires vehicles to yield to oncoming traffic and slows vehicular speeds. Volumes of people walking and riding bicycles and other micro-mobility devices like scooters are anticipated to be lower since residential development is less dense. Due to anticipated low motor vehicle volumes and low speeds, people on bikes will share the lane with drivers. Sidewalks on both sides of the street provide adequate space for people walking, and for young children to ride bicycles.

The width of the street is based on housing density and corresponding motor vehicle traffic volume as noted in Section 2.6.B.

### Features:

- Residential areas
- Low volume two-way traffic
- Shared lane
- Sidewalks
- On-street parking
- Curb-to-curb width based on density
  - 24' in low density areas
  - 26' in low-moderate density areas
  - 28' in moderate density areas

Figure 1-9. Neighborhood Yield Street.



TABLE 1-8. NEIGHBORHOOD YIELD STREET DIMENSIONS AND CHARACTERISTICS

Street Type	Right of Way Width	Center Turn Lane/Median	Inside Travel Lane*	Outside Travel Lane	Shoulder/Offset from Curb	Parallel Parking	On-Street Bike Lane	Buffer Zone***	Separate Bike Lane	Sidewalk	Shared Use Path	Target Speed	Carrying Capacity
Neighborhood Yield Street	50'	N/A	N/A	12'/13'/14' **	N/A	flexible	N/A	6'/6'/5'	N/A	5' min (2 sides)	N/A	25 mph	<2k

\*Against center line/median; \*\* Includes 1' gutter pan; \*\*\*Dimension measured from back of curb to sidewalk/separated bike lane/shared use path

## Alley

The Alley street type is intended for local access to residential and commercial areas in all land use and zoning categories. Due to very low motor vehicle volumes, this street is shared by all users including pedestrians and people riding bikes.

### Features:

- Countywide
- 1-lane driveway/garage access
- Shared lane
- No sidewalks
- No on-street parking
- Privately owned

Figure 1-10. Alley.



TABLE 1-9. ALLEY DIMENSIONS AND CHARACTERISTICS

Street Type	Right of Way Width	Center Turn Lane/Median	Inside Travel Lane*	Outside Travel Lane	Shoulder/Offset from Curb	Parallel Parking	On-Street Bike Lane	Buffer Zone***	Separate Bike Lane	Sidewalk	Shared Use Path	Target Speed	Carrying Capacity
Alley	24'	N/A	N/A	10'	N/A	N/A	N/A	N/A	N/A	N/A	N/A	15 mph	local

\*Against center line/median, \*\* Includes 1' gutter pan, \*\*\*Dimension measured from back of curb to sidewalk/separated bike lane/shared use path

## Industrial Street

The Industrial Street type is intended for industrial areas. Volumes of people walking and riding bicycles and other micro-mobility devices like scooters will vary. Due to anticipated high truck volumes, a shared use path is recommended instead of an unprotected on-street bike lane. A shared use path is recommended on one side of the street, and a sidewalk on the other. The 40-foot curb to curb width accommodates multiple configurations, including on street parking on both sides of the street or a three lane roadway with a center turn lane.

### Features:

- Industrial areas
- Marked centerline
- Shared use path
- Sidewalk
- Flexible configuration
  - 40' curb to curb
  - Could be striped as two lanes with outside used for parking (shown)
  - Could be striped as three lanes if needed

Figure 1-11. Industrial Street.



TABLE 1-10. INDUSTRIAL STREET DIMENSIONS AND CHARACTERISTICS

Street Type	Right of Way Width	Center Turn Lane/Median	Inside Travel Lane*	Outside Travel Lane	Shoulder/Offset from Curb	Parallel Parking	On-Street Bike Lane	Buffer Zone***	Separate Bike Lane	Sidewalk	Shared Use Path	Target Speed	Carrying Capacity
Industrial Street	76'	N/A	N/A	12'	N/A	8' **	N/A	6'	N/A	5' (1 side)	10' (1 side)	25 mph	10-15k

\*Against center line/median; \*\* Includes 1' gutter pan; \*\*\*Dimension measured from back of curb to sidewalk/separated bike lane/shared use path

## Country Road

The Country Road street type is intended for low density rural areas. Volumes of people walking and riding bicycles and other micro-mobility devices like scooters are anticipated to be low since residential and commercial development is spread out. Eight-foot shoulders are wide enough to accommodate people walking and bicycling. The open section drains to buffers adjacent to the roadway which capture run-off. In places where there is an existing shared use path network or a network is planned in *BikeHoward*, a shared use path could be provided in place of shoulders at the discretion of the County.

### Features:

- Rural/low density areas
- Collector
- Two-lane street
- On-road bike lanes
- No sidewalks
- No on-street parking

Figure 1-12. Country Road.

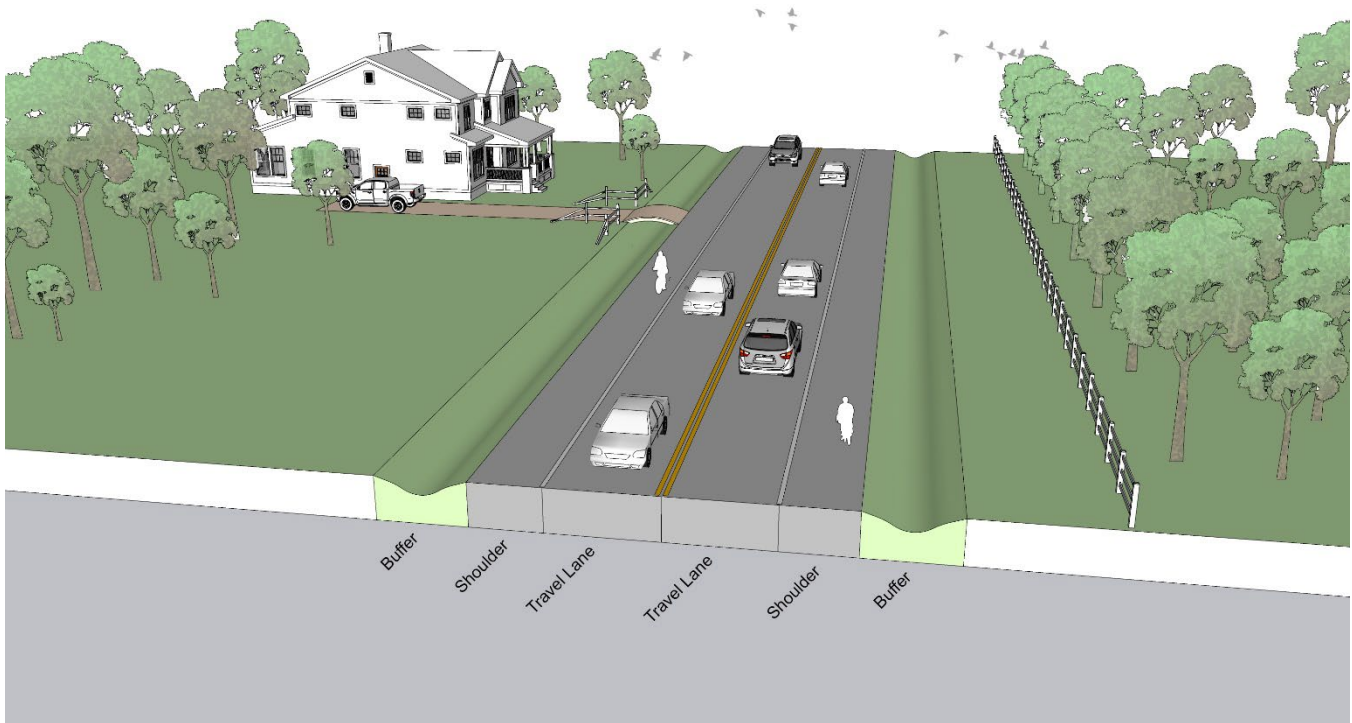

TABLE 1-11. COUNTRY ROAD DIMENSIONS AND CHARACTERISTICS

Street Type	Right of Way Width	Center Turn Lane/Median	Inside Travel Lane*	Outside Travel Lane	Shoulder/Offset from Curb	Parallel Parking	On-Street Bike Lane	Buffer Zone***	Separate Bike Lane	Sidewalk	Shared Use Path	Target Speed	Carrying Capacity
Country Road	60'	N/A	N/A	12'	8'	N/A	shoulder	10' buffer	N/A	N/A	N/A	varies	10-15k

\*Against center line/median; \*\* Includes 1' gutter pan; \*\*\*Dimension measured from back of curb to sidewalk/separated bike lane/shared use path



## Rural Development Street

The Rural Development Street type is intended for low density rural residential areas. On-street parking effectively narrows the roadway, which requires vehicles to yield to oncoming traffic and slows vehicular speeds. Volumes of people walking and riding bicycles and other micro-mobility devices like scooters are anticipated to be low since residential development is less dense. Due to anticipated low motor vehicle volumes and low speeds, this street is shared by all users including pedestrians and people riding bikes. The open section drains to buffers adjacent to the roadway which capture run-off.

### Features:

- Rural/low-density residential areas
- Low volume two-way traffic
- Shared lane
- No on-street parking

Figure 1-13. Rural Development Street.



TABLE 1-12. RURAL DEVELOPMENT STREET DIMENSIONS AND CHARACTERISTICS

Street Type	Right of Way Width	Center Turn Lane/Median	Inside Travel Lane*	Outside Travel Lane	Shoulder/Offset from Curb	Parallel Parking	On-Street Bike Lane	Buffer Zone**	Separate Bike Lane	Sidewalk	Shared Use Path	Target Speed	Carrying Capacity
Rural Development Street	50'	N/A	N/A	12'	N/A	flexible	N/A	13'	N/A	N/A	N/A	25 mph	local

\*Against center line/median; \*\* Includes 1' gutter pan; \*\*\*Dimension measured from back of curb to sidewalk/separated bike lane/shared use path

TABLE 1-13. HOWARD COUNTY STREET TYPES FOR NEW CONSTRUCTION

Type	ROW Width	Center Turn Lane/Median	Inside Travel Lane*	Outside Travel Lane	Shoulder/Offset from Curb	Parallel Parking	On-Street Bike Lane	Buffer Zone***	Separated Bike Lane	Sidewalk	Shared Use Path (SUP)	Carrying Capacity	Target Speed
Boulevard	116'	11' **/16'	11' **	11'	N/A	8' **	N/A	6'	6.5'	5' min. (2 sides)	N/A	35-40k	25 mph
Boulevard No Parking	100'	11' **/16'	11' **	11' **	N/A	N/A	N/A	6'	6.5'	5' min. (2 sides)	N/A	35-40k	25 mph
Town Center Connector	88'	11'	N/A	11'	N/A	8' **	N/A	6'	6.5'	5' min. (2 sides)	N/A	<20k	25 mph
Town Center Connector No Parking	72'	11'	N/A	11' **	N/A	N/A	N/A	6'	6.5'	5' min. (2 sides)	N/A	<20k	25 mph
Town Center Street	76'	N/A	N/A	10.5'	N/A	8' **	N/A	6'	6.5'	5' min. (2 sides)	N/A	<12k	25 mph
Town Center Street No Parking	64'	N/A	N/A	12' **	N/A	N/A	N/A	6'	6.5'	5' min. (2 sides)	N/A	<12k	25 mph
Parkway (6-lane)	122'	11' **/16' min.	12' **	11'	1'	N/A	N/A	6'	N/A	N/A	10' (2 sides)	50k-60k	varies
Parkway (4-lane)	112'	11' **/28'	12' **	11'	1'	N/A	N/A	6'	N/A	N/A	10' (2 sides)	35-40k	varies
Neighborhood Connector	86'	11'/9'	N/A	11'/12' ** at median	N/A	8' **	N/A	6'	N/A	N/A	10' (2 sides)	<20k	30 mph
Neighborhood Connector No Parking	70'	11'/9'	N/A	11' **/12' ** at median	N/A	N/A	N/A	6'	N/A	N/A	10' (2 sides)	<20k	30 mph
Neighborhood Street 1	76'	N/A	N/A	10'	N/A	8' **	5' lane 2' buffer	6'	N/A	5' (2 sides)	N/A	<12k	25 mph
Neighborhood Street 1 No Parking	62'	N/A	N/A	10'	N/A	N/A	6' lane ** 2' buffer	6'	N/A	5' (2 sides)	N/A	<12k	25 mph
Neighborhood Street 2	74'	N/A	N/A	10.5'	N/A	8' **	N/A	6'	N/A	5' (1 side)	10' (1 side)	<12k	25 mph
Neighborhood Street 2 No Parking	60'	N/A	N/A	12' **	N/A	N/A	N/A	6'	N/A	5' (1 side)	10' (1 side)	<12k	25 mph
Neighborhood Yield Street	50'	N/A	N/A	12'/13'/14' **	N/A	flexible	N/A	6'/6'/5'	N/A	5' (2 sides)	N/A	<2k	25 mph
Alley	24'	N/A	N/A	10'	N/A	N/A	N/A	N/A	N/A	N/A	N/A	local	15 mph
Industrial Street	76'	N/A	N/A	12'	N/A	8' **	N/A	6'	N/A	5' (1 side)	10' (1 side)	10-15k	25 mph
Country Road	60'	N/A	N/A	12'	8'	N/A	shoulder	10' buffer	N/A	N/A	N/A	10-15k	varies
Rural Development Street	50'	N/A	N/A	12'	N/A	flexible	N/A	13'	N/A	N/A	N/A	local	25 mph

\* Against center line/median; \*\* Includes 1' gutter pan; \*\*\* Dimension measured from back of curb to sidewalk/separated bike lane/shared use path.

## D. Scenic Roadways

Scenic roadways are designated by County Council Resolution in accordance with Section 16.1403 of the Howard County Code. They are typically local, collector, or minor arterial roads. Although their function varies, they generally carry low motor vehicle traffic volumes and often have no facilities for pedestrians or bicyclists.

Carefully designed localized improvements to improve safety for motorists and people bicycling are allowable provided that they retain the scenic quality of the road.

The following principles should be used in the maintenance of scenic roadways to retain their aesthetic characteristics:

1. Do not alter the existing width of the pavement or shoulders or the roadway alignment during road, utility, or drainage maintenance. Pavement restriping, removal of vegetation and signage installation is permitted to improve safety.
2. Maintain roadway embankments to be a natural characteristic of the road. Mitigate erosion and similar problems by plantings.
3. Limit tree trimming and removal to work necessary to improve sight distance and safety and for prudent forest management. Minimize disturbance to mature trees.
4. Control vegetation as necessary by mowing or selective cutting. Allow natural vegetation to become established as close to the shoulder-edge as possible, while allowing for adequate sight distance.
5. If street lights are installed, they should be installed at the lowest height feasible for the location. Fixtures should be directed downwards onto the road. Lights should be of a material and style compatible with the neighborhood.
6. Materials to repair bridges and walls should match existing materials.

Accommodation of people walking and bicycling is as important along scenic roadways as it is on other streets in the County. As an example, scenic roadways, and especially bridges along those roadways, may provide scenic views for people walking and bicycling along the roadway. The Designer must apply creativity in the selection of appropriate walking and bicycling facilities for a scenic roadway to maintain both the comfort of all users of the roadway and the roadway's scenic characteristics.

The LTS goals in Section 1.3.C apply to all streets, including scenic roadways. Options available to the Designer include, but are not limited to, the following:

- Provision of pedestrian facilities and LTS 2 or better bicycle facilities on a parallel route that provides walking and bicycling access to the same destinations that facilities on the scenic roadway would serve.
- Provision of a shared use path along the scenic roadway, sited in a manner that complements the scenic characteristics of the roadway for all road users while still providing high-quality walking and bicycling access.
- Reduction of prevailing motor vehicle speeds along the scenic roadway to allow LTS goals to be achieved without separate bicycle facilities. Speed management (see Chapter 2, Section 2.2.E.10) must not only be effective in reducing prevailing motor vehicle speeds, but must also be designed to complement the roadway's scenic character.

## E. Retrofit Projects

The Street Types in Section 1.3.C are ideal for new construction. In retrofit situations, either for capital projects or for developer improvements to existing streets and roads, limited right of way and other constraints may make provision of the ideal street type less feasible. This section provides guidance for retrofits.

### 1. Preferred Cross Section

The first step in this process is to establish the preferred cross section for the street. In most cases, this will be as defined in Section 1.3.C, with corresponding dimensions in Volume IV. The number of motor vehicle lanes for street types with more than one lane in each direction (e.g. Boulevard and Parkway) must be determined by accommodation of anticipated motor vehicle traffic volumes at an acceptable level of service. Similarly, in circumstances where numbers of people walking and bicycling along shared use paths are expected to be high, the Federal Highway Administration's (FHWA's) "Shared-Use Path Level of Service Calculator," available online, shall be used to determine if a shared use path should be wider than the ten feet shown in the typical street types (Ref. 11). Methods for conducting the multimodal traffic studies needed for these analyses are described in Chapter 5.

If the preferred cross section can be accommodated based on site conditions and the scope of the project, it shall be designed and constructed accordingly. The County (in the case of capital projects) or the Developer (in the case of land development projects) shall make a good faith effort to acquire any right of way needed to construct the preferred cross section.

In some cases, right of way to accommodate the preferred cross section cannot be obtained, or physical constraints (steep slopes, wetlands or other environmental resources, proximity to buildings, etc.) don't allow for the practical construction of the preferred cross section. Similarly, in the case of resurfacing and minor retrofit projects, where the scope and budget of the project are not sufficient to move curbs or drainage, it may not be feasible to implement the preferred cross section. In those circumstances, trade-offs must be considered.

### 2. Trade-Offs

Because every retrofit situation is different, it is incumbent upon the Designer to consider guidance in this section, along with site constraints, to determine the appropriate typical section. There are many options available to reallocate available space to accommodate facilities for all modes of travel. The FHWA "Bikeway Selection Guide" shall be consulted, as it provides clear direction that is consistent with the County's Complete Streets policy (Ref. 12). The Guide states, "One user's convenience or mobility should not be prioritized over another user's safety." Furthermore, "When evaluating safety trade-offs, options that reduce serious injuries and fatalities should be prioritized over options that may reduce property damage or minor injuries." In many cases, this approach will dictate that facilities for the most vulnerable users of the streets – people walking and bicycling – be prioritized over other goals that may have been established by the County for motor vehicle level of service thresholds.

For projects where trade-offs are difficult, the Designer shall develop multiple alternatives for consideration by the community. See Section 1.2.D for the role of community engagement in the project development process.

The following options, listed in no particular order, are available to the Designer to fit a street section into a constrained area. As stated in the Complete Streets policy, "when space is a limiting factor and where vulnerable users are likely, allocating space to a mode that is not currently accommodated shall be prioritized over providing additional space to a mode that is already accommodated." Creativity is required on the part of the Designer to address the particular circumstances of the project, as every project is unique. Examples of creative design solutions may include, but are not limited to, the following:



- **Reduce median width.** Medians are an important safety treatment for higher-volume streets to separate directions of motor vehicle travel. For that reason, removal of medians on four- or six-lane streets is not recommended. However, a reduction in median width may be appropriate. Median widths for Boulevard and Parkway street types are designed to accommodate passenger car U-turns. If it is possible to prohibit U-turns or accommodate them through alternative movements in the street network, the curb-to-curb width of the median may be reduced to as little as six feet. Six feet is the minimum width to allow the median to serve as a pedestrian refuge. A wider refuge may be beneficial where there are higher volumes of people walking and bicycling across the street, or to accommodate larger bicycles such as tandems, cargo bikes, and bikes with trailers.
- **Reduce width of motor vehicle lanes.** At prevailing motor vehicle speeds of 45 mph or less, lane widths may be reduced to ten feet unless high volumes of buses or trucks are present. It is preferred for a lane adjacent to a curb to be 11 feet wide (ten feet of pavement plus the one-foot gutter pan).
- **Eliminate on-street parking.** If sufficient off-street parking and loading areas are provided, it may be feasible to eliminate on-street parking.
- **Reduce width of the tree zone.** The six-foot tree zones provided in each street type are designed for three purposes: to provide sufficient width for tree roots while minimizing root damage to adjacent sidewalks and curbs, to accommodate signs, and (in mixed-use areas) to accommodate street furniture. For retrofit projects, the tree zone may also provide an opportunity for micro-scale stormwater management practices. In circumstances where trees are not provided, larger signs are not anticipated, and street furniture is not needed, the width of the tree zone may be reduced.
- **Combine sidewalk-level separated bike lane with sidewalk to create a shared use path.** Street types in mixed-use land use contexts specify a sidewalk-level separated bike lane adjacent to a sidewalk. This additional width is provided because higher volumes of people walking and bicycling are expected in mixed-use areas. In areas where those high volumes are not anticipated, it may be feasible to combine the two to create a shared use path. In general, the shared use path should be at least ten feet wide. The Shared-Use Path Level of Service Calculator may recommend a wider path.
- **Reduce number of motor vehicle lanes.** The Designer should consider the impact of reducing the number of motor vehicle lanes, including turn lanes, on traffic operations. See the FHWA “Road Diet Informational Guide” for additional guidance (Ref. 13).
- **Locate some elements of the typical section outside the right of way.** It may be desirable to place the outside elements of the typical section (generally sidewalks or shared use paths) in easements outside the right of way where right of way cannot be acquired. Providing these facilities outside the right of way shall be prioritized over eliminating those facilities from the design.
- **Reduce shared use path width.** A shared use path width of ten feet is the minimum generally recommended to minimize conflicts between people walking and bicycling. As noted above, the Shared-Use Path Level of Service Calculator may recommend an even wider path in areas with high walking and bicycling activity. By contrast, in constrained areas, a narrower path width may be considered. The AASHTO Guide for the Development of Bicycle Facilities provides the following guidance for consideration of narrower shared use paths: “In very rare circumstances, a reduced width of 8 ft (2.4 m) may be used where the following conditions prevail:
  - Bicycle traffic is expected to be low, even on peak days or during peak hours.

- Pedestrian use of the facility is not expected to be more than occasional.
- Horizontal and vertical alignments provide frequent, well-designed passing and resting opportunities.
- The path will not be regularly subjected to maintenance vehicle loading conditions that would cause pavement edge damage.

“In addition, a path width of 8 ft (2.4 m) may be used for a short distance due to a physical constraint such as an environmental feature, bridge abutment, utility structure, fence, and such.”

- **Eliminate sidewalk or shared use path on one side of the street.** In unusual circumstances, there may be a street segment that has no destinations for people walking or bicycling on one side. One example would be a natural area that does not have walking or bicycling access. If that circumstance exists, and if those destinations are not planned in the future, it may be feasible to eliminate the sidewalk or shared use path on that side of the street. The opportunity to walk or bike in both directions along the street must be preserved. This means that at each end of the segment where a sidewalk or shared use path is not provided on one side, a low stress crossing of the street must be provided.
- **Downgrade bicycle facility type.** One guiding principle of street design in this Manual is provision of bicycle facilities that operate at LTS 2 or better (or LTS 1 in the vicinity of specific destinations). In some constrained locations, it may be feasible to provide a higher stress bicycle facility where a lower stress facility does not fit. For example, conventional striped bike lanes may fit in an area where separated or buffered bike lanes do not.

In locations where the road width only supports the addition of one bike lane, a “climbing lane” can be provided in the uphill direction, and a shared lane marking can be provided on the downhill portion of the road. “Bicycles May Use Full Lane” (R4-11) signs may be used in the downhill direction.

In cases where the bicycle facility type must be downgraded due to site constraints, the Designer shall consider what measures can be provided to reduce motor vehicle speeds. Because LTS depends on both facility type and prevailing motor vehicle speed, it may be possible to maintain a desirable LTS by implementing a combination of narrower bicycle facilities and traffic calming to reduce speeds.

- **Provide lower-stress bicycle connectivity on an alternate route which provides similar access.** While a more common approach in urban areas with a grid network of streets, Howard County’s street patterns often do not lend themselves to providing multiple parallel routes. This option should only be considered in situations that are so constrained that a bicycle facility simply cannot be provided without extraordinary impacts, or when the parallel route is shorter, has more favorable grades or provides other advantages to the cyclist. In cases such as this, the Designer should identify what alternative route is available to bicyclists and, if it can be accommodated within the scope of the project, include bicycle facility improvements on the parallel route to obtain an acceptable LTS.

## 1.4 Engineering Reports

### A. Purpose of Report

All capital improvement projects which involve significant expenditure of construction funds shall require the preparation of a preliminary engineering report. The purpose of the report is to consider the feasibility of the various alternatives for solving a given problem and establishing the basis for selecting the most feasible solution to the problem and the recommended course of action to affect the solution.

### B. Content of Report

Engineering reports vary in their complexity and subject matter based on the type and the particular circumstances of the project being studied. However, all reports shall contain at least the following information:

- Purpose and scope of the study performed
- Description of existing conditions, problems and project history in general
- Establishment of appropriate design criteria on which the study is based
- Description of all feasible alternatives that were studied
- Description of public engagement process and input that was received
- Comparison of alternatives including cost estimates (construction, right-of-way, utility relocation, etc.), environmental impacts, design characteristics, serviceability, impacts to all modes of travel, accommodations for all modes of travel, and impacts to utilities during construction and other pertinent features.
- Conclusions
- Recommendations

Appropriate exhibits such as vicinity and location maps, sketch plan layout of the alternative designs, profiles, typical sections of details and tables shall be included to support and depict the written material in the report.

### C. Submission for Review

All reports shall be submitted on 8-1/2 inch by 11-inch bond paper from approved word processor, suitable for reproduction and bound in a booklet with a suitable cover. Maps, plans, profiles, tables, etc. shall be either 8-1/2 inches by 11 inches or folded to that size for binding in the report booklet unless otherwise approved by DPW. The scale of the maps may vary to meet their intended purpose.

Preliminary draft of the report shall be submitted to DPW for review.

After incorporating any modifications or revisions made during the review, the final report shall be signed by a Professional Engineer and submitted to DPW.

### D. Public Meetings

The Department of Public Works shall schedule all public meetings concerning proposed projects and shall coordinate all preparation of exhibits, scripts and brochures and conduct the public meeting presentation. The Designer shall assist in the preparation of the public meeting and the presentation as requested by DPW.

## 1.5 Control, Topographic and Construction Surveys

### A. Control Surveys

1. All survey controls of capital project for the design and construction of road and bridges shall be established based upon the Howard County DPW Procedures 501.7, "Specifications for Surveying Procedures and Documents," latest edition.
2. Horizontal control shall be established by conventional closed traverse or Global Positioning System (GPS) surveys. All horizontal control shall be tied to the Maryland State Plane Coordinate System, utilizing the monumentation of the National Geodetic Survey (NGS) or the Howard County Geodetic Survey Stations. The State Plane Coordinate System Datum shall be specified (i.e. NAD. 83 or NAD. 83/91).
3. Conventional traverses shall have a minimum closure ratio of 1:15,000. GPS control points shall be established in accordance with the specifications and requirements of the Federal Geodetic Control Committee (FGCC) for using GPS relative positioning techniques as amended. All control points shall be referenced in detail on the plans to permanently fixed objects that shall not be disturbed during construction of the proposed project or other projects. Traverse points shall be clearly identified, and coordinates of each point shall be either shown at the traverse point in a neat manner, or in tabulation form on each plan sheet for which the traverse points occur. Bearings and distances between traverse points shall be shown. The traverse shall be assigned continuous stationing, with stations shown every 100 feet and at traverse points, and equalities shown at each intersecting point for spur lines and loops.

4. Vertical control for all projects shall be referenced to the North American Vertical Datum of 1988 (NAVD 88) as projected by Howard County Geodetic Survey Stations. If NAVD 88 control is not available in a one (1) mile radius the project area, the Designer may contact DPW for vertical control. The Designer shall clearly indicate on all plans the datum used. Project benchmarks shall be of a permanent nature and shall be spaced at a maximum distance of 1,000 linear feet. All project benchmarks shall be established by traverse as part of a closed vertical control loop. Benchmarks shall be clearly shown and referenced in detail on the plans. A minimum of two (2) benchmarks shall be shown on each plan sheet.
5. Survey baselines shall be extended for the full length of the project and a minimum of 400 linear feet beyond anticipated limits of work. Station equalities shall be shown for all common intersecting control points. Bearings and distances between control points shall be shown. Coordinates of all control points shall be either shown at the control point in a neat manner or in tabulation form on each plan sheet for which the control points occur.

### B. Topographic Surveys

#### 1. Limits of Area Covered

The limits of the area to be shown on the plans may vary to some degree on various types of projects, and in general for Capital Projects, the area covered is usually a continuous strip of a minimum of 100 feet outside of the proposed limits of disturbance on each side of the facility and 400 feet beyond the anticipated limits of work (for Developer Projects, limits of work shall be as required on a case by case basis or in accordance with Subdivision and Land Development Regulations).

#### 1. Items to Include in Topographic Surveys

- a. All buildings and other structures within and immediately adjacent to the project limits, together with all improvements, including wells, springs, septic tanks, drain fields, dry wells, etc.

- b. Property and right-of-way lines (proposed and existing) including right-of-way widths and identifying road names.
- c. Property information:
  - 1) Owner name(s)
  - 2) Front foot distances of each property along the facility
  - 3) Deed and recording references, including parcel number, lot number, subdivision name and record plat reference(s)
  - 4) Property pipes, monuments or markers
  - 5) Street address
- d. Roadway pavement, curb lines, driveway entrances, walkways, fences, walls, etc., including types of materials, widths, heights, and all other descriptive data.
- e. Horizontal and vertical location of all water mains, valves, fire hydrants, meters, sanitary sewer mains, manholes, clean-outs, storm drain inlets and culverts.
- f. Horizontal and vertical location of all existing and proposed overhead, surface and subsurface gas, electric, telephone and cable utilities as determined by field surveys, or other proposed plans, and fully coordinated with existing record drawings and applicable utility companies.
- g. Trees:
  - 1) Trees 12-inches in diameter and larger within proposed rights-of-way shall be individually located and identified by type. All trees, regardless of size, shall be located and identified by size and type that exist on the landscaped area of the property, including hedges, shrubs, flower beds, etc.
  - 2) For trees whose foliage overhangs the right-of-way or construction strip, the extent and diameter of the foliage (fall line) shall also be indicated.
  - 3) Tree stands or woods line shall be located and general characteristics of the wooded area given including approximate average size of the trees, density and general type of trees represented.
  - 4) Brush and dense undercover areas shall be so noted as applicable.
- h. Water courses, such as streams, swales and ditch areas, shall be shown and located including width, depth and water depth data, if applicable. Water courses shall be contoured from field data together with the 100-year flood plain and elevations shown on the plans. Contours shall be shown on both sides of the water course and extended at least 100 feet beyond the parallel alignment of the proposed facility. The flood plain data shall be determined by the Designer with criteria based on existing zoning and full future development of the drainage area.
- i. Embankments and other irregularities of terrain including roadside drainage ditches shall be shown and spot elevations of top and bottom of the bank given every 50 feet.
- j. Stormwater management facilities shall be shown and located including inlet and outlet structure(s), size and inverts of pipe(s), water level elevation, if applicable, clean outs, observation wells. Contours of the facilities shall be shown and extend 100 feet beyond the limits of the facility.
- k. Limits of existing wetlands and Waters of the U.S. including buffers.
- l. Vehicular access routes for off road or undeveloped areas shall be identified for use during construction.
- m. Identify and reference contract numbers and project numbers of all existing and proposed facilities within and adjacent to the project limits.
- n. In new developments where the terrain is being transformed, most of the information shall be obtained directly from approved plans prepared to satisfy proposed improvements including curbs, storm drains, street rights of way and lots as taken from the record plat and construction plans and shall show all existing features that are to remain undisturbed.



2. Method of Locating Topography

- a. The method of locating topography shall be by field surveys utilizing the radial survey method, the GPS Real Time Kinematic (RTK) method or the right angle plus offset method. Survey field notes may be kept in the classical method (handwritten notes) or by the electronic data collection method as per the Howard County DPW Departmental Procedures 501.7, "Specifications for Surveying Procedures and Documents", latest edition.
- b. Topography may be provided by aerial photogrammetry for engineering studies and drainage area maps. All vertical survey requirements for preliminary and final design shall be acquired by actual field surveys, unless otherwise approved by DPW.
- c. The Howard County Survey Division will furnish field books for classical methods.

3. Existing and Proposed Contour Lines

If required, existing and proposed contour lines shall be shown on the plans. Sufficient information shall be obtained in order to allow the contours to be shown at 2-foot intervals or less. In areas of steep slopes (greater than 20%), contours may be shown at 5-foot intervals with the approval of DPW.

4. Cross-sections

Cross-sections shall be taken at fifty (50) foot stations and at intersecting roads, driveways, entrances, rivers, streams, and railroads. Cross-sections shall be at right angles or radial to the proposed alignment and extend a minimum of 100 feet beyond each side of the proposed facility and a minimum of 200 feet beyond anticipated project limits. The minimum distances shown herein shall be extended accordingly in order to provide sufficient information to established profile grade lines beyond the actual project limits or to locate other topography or topographic relief, relative to the design or construction of the proposed improvements. Cross sections shall be plotted on standard cross-section sheets of a quality that will provide acceptable prints.

5. Property Corners

Property corners within the construction area shall be referenced such that they may be reset after construction.

6. Howard County Survey Control Stations

Howard County Survey Control Stations that will be affected by the proposed construction shall be noted on the plans as being protected or to be relocated accordingly. Where there is a need to protect or relocate Control Stations, DPW shall be notified by the Designer in writing prior to the approval of the plans.

## 1.6 Preparation of Construction Plans

### A. General

Contract documents for construction of County or Developer Projects in Howard County are commonly comprised of construction plans and the construction specifications. Taken together, these documents form the basis for the construction contract between the Owner and Contractor. Contract documents are prepared by the Designer, who is responsible for a complete description of all work to be performed, in accordance with the Standard Specifications, Volume IV. The Designer remains responsible for adequately designing, detailing, and specifying through the Special Provisions and the Technical Specifications, all contract-specific materials and methods of construction not described in the Standard Specifications, Volume IV.

### B. Purpose

1. The primary purpose of construction plans is to show the size, horizontal and vertical location and type of materials and structures to be installed as part of a highway facility. The construction plans must be developed in sufficient detail to depict the improvements and their spatial relationship with both existing conditions and planned future improvements.
2. This section sets forth requirements for information to be placed on construction plans. When completed according to County standards and properly implemented in construction, the original highway facility forms a permanent record of the completed work and the materials employed on the project.

### C. Drafting and Graphic Standards

#### 1. Sheet Size, Borders and Materials

All highway construction projects shall be prepared on 24" x 36" Mylar drafting film (minimum thickness 0.004 inches, matted both sides). Borders shall be ½-inch on all sides with the exception of the left side, which shall be 1¾ inches, with standard title block. All drafting and lettering shall be performed directly on the original plans and no reproductions, rub-on or adhesive materials shall be used.

#### 2. Computer-aided Drafting (CAD)

Computer-aided drafting may be used on any project if the Designer so desires. All requirements of this section, "Drafting and Graphic Standards," must be met. Plotters used for CAD must be equipped with technical ballpoint pens or standard drafting pens or any electronic printer device. Electronic deliverables to the County (i.e. CAD disks, CDs, etc.) must be in software formatting compatible with existing County systems. The format to be used will be decided at the pre-design meeting.

#### 3. Scale

Highway plans shall be drawn on a scale of 1" = 50'. Roadway profiles are typically drawn to accompany the plan layout and shall be shown below the applicable plan layout on each sheet. Profiles shall be drawn to a horizontal scale of 1" = 50' and a vertical scale of 1" = 5'. The scale to be used for details on any one set of drawings shall be 1/4", 3/8", 1/2", 3/4", 1", or 1 ½" = 1' - 0".

#### 4. Use of Standard Symbols and Abbreviations

The "Standard Symbols and Abbreviations" shown in the Standard Specifications, Volume IV shall be used wherever possible. Non-standard symbols and abbreviations deemed necessary shall be clearly defined in a legend on the title sheet.

#### 5. Lettering

Vertical lettering shall be used throughout. Lettering shall be uniform, neat in appearance, free of stylization, and large enough to be read when reduced for County filing. Lettering for titles, sub-titles and notes placed on the drawings shall be the size approved by DPW and as shown in the "General Drafting Standards" in the Standard Specifications, Volume IV. All notes, descriptions, etc. shall be minimum of No. 4 (4/32-inch) in size and shall be either all upper case or all lower case. Proper names only shall be capitalized. Construction notes shall not be placed in shaded areas. Crowding of notes into a small space shall be avoided. Leaders shall be used to identify the object to which each note refers. All lettering in the same contract shall be of the same style.

## 6. Vicinity Map and Initial Drawing

- a. The first sheet of all projects shall include a 1" = 600' scale vicinity map with three unique sets of grid coordinates, sufficient road names and other features to allow easy recognition of the site. When a set of contract plans contain only one or two sheets the vicinity map shall be placed at the upper right portion of the first plan sheet in a space measuring 8½-inches vertically by 11-inches horizontally. If the vicinity map cannot fit in the 8½ x 11-inch space or whenever there are three (3) or more sheets to the contract, then the first sheet shall be designed as a title sheet with the vicinity map centered on the plan. When the 1" = 600' scale location map exceeds the size of the sheet, the map shall be drawn at a scale of 1" = 1,000'.
- b. In addition to the vicinity map, the initial plan shall show the contract title, contract number and project number. If the project is divided into two or more contracts, each associated contract shall be identified on the vicinity map. Likewise, the plan coverage of each sheet of the construction plans shall be shown on the vicinity map with its corresponding sheet number for ready reference. For projects with more than three plans (total), a complete sheet index shall also be provided on the title sheet indicating the data shown on each sheet.
- c. When space permits, the first plan of a set shall also show the General Notes pertaining to the contract. If the notes cannot be placed on the initial sheet, a note shall be included on the initial sheet indicating on which sheet the General Notes appear.

## 7. Information Required on Each Construction Plan

## a. General

The purpose of the contract plans is to portray graphically to the review agencies, project engineer and contractor the nature and extent of the proposed work and the conditions under which the work is to be performed. All information that can best be shown by plans and their accompanying dimensions and notes should be shown on the contract plans or appropriate reference to the County's Standard Details, Volume IV made where applicable. Lengthy written descriptions or requirements regarding the work are best included in the specifications, and therefore, shall not be repeated on the plans.

## b. Title Block

Each sheet shall have a title block along the lower border of the sheet. The title block shall show the project name, sheet title, contract number, scale, 1" = 600' scale reference map number and block numbers, date, sheet number and signature blocks for DPW and/or DPZ. Sheets shall be numbered sequentially 1 through X, where X is the total number of sheets in the contract. Each discipline shall also number each sheet in its group sequentially and prefix the sheet number with a letter abbreviation representing the discipline, e.g. C1 through CX for Civil, where X is the number of plan sheets in the discipline. See Appendix B, "Standard Reference Plan," for specific format.

## c. Seal and Signature

The professional engineer's seal, original signature and registration number belonging to the Designer responsible for the design, registered in the State of Maryland, shall be shown on the title block of the first sheet and each finished sheet of the set of plans. The date on which seal and signature were affixed to the plans shall be shown in the same location on all the sheets.

The Designer's seal, signature, registration number and date of signature shall also be shown on the first page of the project specifications.

d. Revision Box

Each sheet shall have a revision box in the title block. The revision box shall document all revisions after the Designer's seal and signature has been affixed to the plan and the plan has been signed by the approving authority. See Appendix B, "Standard Reference Plan", for location of revision box.

e. Benchmarks and Traverse Points

A tabulation of benchmark descriptions and elevations shall be shown on the sheet that the benchmark occurs. A minimum of two benchmarks shall be shown on each plan sheet. Traverse point recovery diagrams with dimensions shall be shown for each traverse point on the sheet where the traverse point occurs. Traverse referencing shall be made to permanently fixed objects that will not be disturbed during construction of the proposed project or other projects. Where ever possible, permanently fixed objects used to locate traverse points shall appear on the plan. Traverse points shall be clearly identified and coordinates of each point shall be either shown at the traverse point in a neat manner, or in tabulation form, on each plan sheet for which the traverse points occur. Bearings and distances between traverse points shall be shown. The traverse shall be assigned continuous stationing, with stations shown every 100 feet and at traverse points, and equalities shown at each intersecting point for spur lines and loops.

f. North Arrow and Grid Ticks

Each plan sheet and location map shall have a north arrow. Plan sheets shall be oriented so that the north arrow points toward the top or toward the right side of the sheet, or toward the upper right quadrant of the sheet.

Each plan sheet shall show a minimum of three coordinated grid ticks based on the Maryland State Plane Coordinate System and all bearings shall be related to grid north. Two of these grid ticks shall be on the same N-S or E-W line, forming a right-angle arrangement. The coordinated grid ticks shall be at multiples of 250 feet.

g. Contract Limits

The limits of the contract shall be clearly shown on all plans.

h. Match Lines and Cross-references

All plans in the same contract shall be cross-referenced by ascending numbers. Match lines with a minimum length of 4 inches shall be used wherever the plan is to be continued on the same or another sheet. Data shall be cut off at the match line; duplication of data on matching sheets is not permitted.

i. Sediment and Erosion Control Sheets

1) Approval and Certificate Blocks: Sediment and erosion control sheets shall contain developer's and engineer's certifications. The Designer shall contact the Howard Soil Conservation District for current certification blocks.

2) All road and bridge construction projects that require sediment control shall have detail sheets with required notes dedicated exclusively to sediment control. Existing and proposed contour lines shall be shown on the erosion and sediment control plans in accordance with the requirements of the Howard Soil Conservation District. Contours shall be displayed as required on separate erosion and sediment control plans. If approved by DPW/DPZ, the contours may be screened to a 50% level. All sediment and erosion control plans and specifications are reviewed and approved by the Howard Soil Conservation District.

#### j. Checklists

The Designer shall fully complete the "Preliminary Plan" and "Final Construction Plans" checklist(s). The Designer shall verify that all information detailed on the checklist is shown on the plans. A copy of the checklists may be provided to the Designer together with his notice to proceed, or the Designer may request a copy from the County, as applicable. The appropriate checklist shall be completed and attached to each set of plans submitted for review. This shall apply to all Capital Projects as well as Developer Projects. Land development checklists are also available on the County Internet Site.

#### D. Computer Applications

Computer programs in the public domain and proprietary computer programs may be used by the Designer with the approval of the appropriate County department. Submittal of the programs to be used shall be made at the pre-design meeting. The currently approved computer programs may be identified by contacting the County. To secure approval for the use of additional computer programs, program documentation, especially computational methodology, must be submitted to the County for review prior to the use of the program design.

#### E. Standards for Depicting Existing Conditions

All construction plans shall be drawn to scale and must clearly and completely depict all existing topography and man-made features. In order to develop the required information to scale, the Designer is required to conduct field surveys to accurately establish horizontal and vertical control points along the route of the project based on the system of coordinates adopted by the County. This coordinate system is, in fact, based on the Maryland State Plane Coordinate system and is represented with sufficient accuracy in most cases by monuments and benchmarks interposed by DPW through its aerial and ground mapping program.

Maps based on aerial photogrammetry may not be used for the preparation of construction plans unless sufficient fieldwork is done to make any necessary adjustments to obtain satisfactory accuracy in both the horizontal and vertical planes.

In surveying, plotting and drafting of existing features onto the construction plans, the inclusion or elimination of information must be carefully evaluated in the interest of efficiency of work, clarification of plans and sufficiency of representative information. A complete listing of required survey and as-built information to be included on the base plans is given elsewhere in this chapter. On projects requiring more detailed information, it is the responsibility of the Designer to recognize the extent and detail of information necessary to show a complete picture of the project area. However, in no case shall the Designer show less than the requirements given elsewhere in this chapter.

Instructions for conducting and coordinating field surveys together with the requirements for accuracy, note keeping, placing of monuments and benchmarks and other details are set forth in the Department Procedures 501.7, "Specifications for Surveying Procedures and Documents", latest edition.

As previously indicated, existing natural and man-made topographical features as developed through field survey activities are drawn onto the construction plans using standard notes, symbols and established drafting techniques to present a clear representation of the area.

## 1.7 Preparation of Construction Specifications

### A. General

1. Howard County's Standard Specifications are set forth in Volume IV of the Design Manual, "Standard Specifications and Details for Construction." Non-standard specifications, special provisions, proposal form, contract and bond forms and other designated items shall be developed by the Designer specifically for each project and shall be published in booklet form. These requirements apply to Capital Projects only.
2. Upon completion of the construction plans, the Designer is required to provide the necessary non-standard specifications to accompany the plans. A draft of the project specifications shall be submitted with each set of the final plans for review by the County. At this stage of the project, the Designer should be able to finalize most of the non-standard portions of the specification. When all details of the specifications are completed, the Designer shall submit three completed copies of the non-standard portions of the specifications for Developer Projects and the stipulated number of copies of the complete and bound specifications for Capital Projects. The final specification shall have the Designer's Professional Engineer's seal, signature and date of signature on the title page.

### B. Standard Format

Howard County Design Manual Volume IV, Standard Specifications format is to be used in the preparation of the non-standard portions of the specifications.

### C. Special Provisions/Technical Specifications

This section is vitally important to the contract as it contains additions and/or modifications to the Standard Specifications, Volume IV as applicable to each particular contract. The Designer is to contact DPW for advice on those items normally placed in the Special Provisions and/or Technical Specifications. However, it is incumbent on the Designer to include in this section all conditions to the contract and the work required not otherwise covered, such as special construction methods, materials, measurement and payment, etc., so as to provide a complete contract document.

### D. Proposals

1. The proposal form may be designed for a single lump sum payment, a series of unit priced items or a combination of the two. Howard County employs a combination type of proposal where some items of work are bid and paid without regard to measurement. Other items are bid and paid on the basis of a unit of actual measurement multiplied by the corresponding unit price bid by the Contractor or fixed by the contract. The basis of measurement and payment is described in the Standard Specifications, Volume IV and/or in the project specifications.
2. Proposals are often divided into parts to facilitate cost accounting procedures required to allocate costs by projects, administer charges and account for cost participation by various parties involved in the financing.
3. The period of time in calendar days (to be determined by the Designer) permitted for the Contractor to complete the work is stated on the form. The amount of liquidated damages to be charged per day, in the event the work is not completed within the prescribed time period, shall also be given.
4. There are a number of contingent items of work or materials to be employed, which may develop during the course of construction that cannot always be anticipated or that can be anticipated without being qualified. To facilitate the employment of additional materials and the authorization of incidental items of work, all contracts contain a list of fixed price contingent items which are not bid items, which have an assigned unit price and quantity as applicable. These fixed price items are utilized to enable the Contractor to be paid an equitable sum of money when the particular item of work or the furnishing of materials is authorized and directed during the course of construction. Modifications of this list or modification of the fixed prices shall not be made by the Designer except with the full concurrence of DPW.



## 1.8 Record Drawings

### A. General

After the contract plans have been signed by the County, the original contract plans and prints thereof become the property of Howard County. During construction, the Contractor and the County's inspector, acting together, will maintain a set of "as-built" or redlined contract plans. Following construction, the original contract plans shall be revised to reflect the as-built conditions.

By submitting the original contract plans for signature, the Designer agrees to allow the County or its representative to modify the contract plans to reflect the as-built conditions. At the County's option, the County may require the Designer to complete the modifications to the plans to reflect the as-built conditions. The County will hold harmless the Designer for as-built information if added to the drawings by others.

Incorrect information shall be deleted and replaced with the as-built information. The revision block shall be completed, initialed and dated by the individual making the modifications. Each plan in the set shall bear the words "AS-BUILT" in bold letters above the title block on the lower right-hand corner of the plan along with the date that the as-built modifications were completed. All as-built information and lettering shall be of the same style and quality as the original contract drawing.

### B. Electronic Files

If the plans are prepared in electronic format, in addition to the modifications to the original construction plans, the County may require that the electronic files be modified to reflect the as-built conditions and delivered to the County.

### C. Replacement Drawings

Plans bearing original signatures and dates of approval are important for DPW's historical records. However, there may be rare instances where extensive modifications to a plan may render the plan illegible. In order to ensure that the plans are clear and legible, DPW may require that a completely new plan with modifications be developed for the as-built plan. The plan shall be noted as "AS-BUILT Replacement Sheet" above the title block on the lower right-hand corner of the plan and dated. Each new plan sheet shall be circulated for all required signatures.

## 1.9 Definitions

Designer: A professional engineer (or, in some cases, a professional land surveyor or professional landscape architect), registered in the State of Maryland, who is responsible for the design of the project.

Multimodal Transportation Board: An appointed Howard County Board that advises the County Executive and County Administration on transportation matters including public transit (both fixed route and paratransit), bicycle transportation, pedestrian transportation, road networks that promote all modes of transportation, and transportation demand management.

SHA Standard Specifications: Maryland Department of Transportation, State Highway Administration, Standard Specifications for Construction and Materials.

SHA Standard Details: State of Maryland, Department of Transportation, State Highway Administration, Book of Standards, Highway and Incidentals Structures.

Standard Specifications or Standard Details: Howard County Volume IV Design Manual, Standard Specifications and Details for Construction.

## 1.10 Abbreviations

Whenever in this chapter or other chapters, the following abbreviations are used, they will represent:

- AASHTO American Association of State Highway and Transportation Officials
- ACI American Concrete Institute
- ACP Asbestos Cement Pipe
- ADA Americans with Disabilities Act
- ADT Average Daily Traffic
- AISC American Institute of Steel Construction
- ANSI American National Standards Institute
- ASCE American Society of Civil Engineers
- ASHE American Society of Highway Engineers
- ASME American Society of Mechanical Engineers
- ASTM American Society for Testing and Materials
- BOCA Building Officials Conference of America
- CAD Computer-Aided Drafting
- CADD Computer-Aided Design & Drafting
- CIP Cast Iron Pipe
- COMAR Annotated Code of Maryland
- DILP Howard County Department of Inspections, Licenses and Permits
- DIP Ductile Iron Pipe
- DIPRA Ductile Iron Pipe Research Association
- DPZ Howard County Department of Planning and Zoning
- DPW Howard County Department of Public Works
- ENR Engineering News Record
- FCP Forest Conservation Plan
- FGCC Federal Geodetic Control Committee
- FHWA Federal Highway Administration
- FSD Forest Stand Delineation
- GPS Global Positioning System
- HDD Horizontal Directional Drilling
- HDPE High Density Polyethylene
- HGL Hydraulic Grade Line
- HLSD Headlight Sight Distance
- HSCD Howard Soil Conservation District
- HS-20, H-20 Truck Loading Designations
- LRFD Load and Resistance Factor Design
- MDE Maryland Department of the Environment
- MDOT SHA Maryland Department of Transportation State Highway Administration
- MSHA Maryland State Highway Administration
- MTBM Micro-Tunnel Boring Machine
- MUTCD Manual on Uniform Traffic Control Devices for Streets and Highways
- NACTO National Association of City Transportation Officials
- NAD North American Datum
- NAVD North American Vertical Datum
- NGS North Geodetic Survey
- NOI Notice of Intent
- OOT Howard County Office of Transportation
- OSHA Occupational Safety and Health Administration
- PC Point of Curvature
- PCA Portland Cement Association
- PCCP Pre-Stressed Concrete Cylinder Pipe
- PCF Pounds Per Cubic Foot
- PGL Profile Grade Line
- PI Point of Intersection
- PSI Pounds Per Square Inch
- PT Point of Tangency
- PVC Polyvinyl Chloride, Point of Vertical Curve
- PVT Point of Vertical Tangency
- RCP Reinforced Concrete Pipe
- ROW Right of Way
- RQD Rock Quality Designation
- SE Superelevation
- SSD Stopping Sight Distance
- SPT Standard Penetration Test
- SWM Storm Water Management
- VCP Vitrified Clay Pipe
- TCP Traffic Control Plan

## 1.11 References

- (1) “Howard County Pedestrian Master Plan,” Howard County, 2020 or latest version
- (2) “Howard County Bicycle Master Plan,” Howard County, 2016 or latest version
- (3) “Guide for the Planning, Design, and Operation of Pedestrian Facilities,” American Association of State Highway and Transportation Officials (AASHTO), 1<sup>st</sup> Edition (2004) or latest edition
- (4) “Guide for the Development of Bicycle Facilities,” American Association of State Highway and Transportation Officials (AASHTO), 4<sup>th</sup> Edition (2012) or latest edition
- (5) “Urban Bikeway Design Guide,” National Association of City Transportation Officials (NACTO), 2<sup>nd</sup> Edition (2014) or latest edition
- (6) “Manual on Uniform Traffic Control Devices,” Federal Highway Administration (FHWA), 2009 Edition with Revision Numbers 1 and 2 (2012) or latest edition
- (7) “Howard County General Plan,” Howard County, 2012 or latest version
- (8) “Book of Standards – For Highway & Incidental Structures” Maryland Department of Transportation, State Highway Administration (MDOT SHA), (2020) or latest edition
- (9) “Structural Detail Manual,” Maryland Department of Transportation, State Highway Administration (MDOT SHA), (2020) or latest edition
- (10) “Level of Traffic Stress Criteria for Road Segments,” Dr. Peter Furth (Northeastern University), Version 2 (2017) or latest edition
- (11) “Shared-Use Path Level of Service Calculator,” Federal Highway Administration (FHWA), (2006) or latest version
- (12) “Bikeway Selection Guide,” Federal Highway Administration (FHWA), (2019) or latest edition
- (13) “Road Diet Informational Guide,” Federal Highway Administration (FHWA), (2014) or latest edition

## Appendices

- A. Highway Classification Characteristics
- B. Standard Reference Plan
- C. Howard County Complete Streets Policy
- D. Community Engagement Plan
- E. Transportation Classification Map
- F. Street Type – Functional Classification Correlation Chart

## HIGHWAY CLASSIFICATION CHARACTERISTICS

CLASSIFICATION	VOLUME CHARACTERISTICS (ADT)	SERVICE FUNCTION MOVEMENT	SERVICE FUNCTION ACCESS	INTERSECTING ROAD TRAFFIC CONTROL	PUBLIC AND PRIVATE ACCESS CONTROL (1)
Principal Arterial (Freeways)	20,000-100,000 and above	Primary	None	Interchange	Full Control (2)
Intermediate Arterial (Multi-Lane Divided or Un-Divided)	5,000-42,000	Primary	Secondary	Interchange, Signals, Stop Sign, Roundabout	Full (2) or Partial Control (3)
Minor Arterial	2,500-15,000	Primary	Secondary	Signals, Stop Sign, Roundabout	Partial Control (3)
Major Collector	1,500-6,000	Primary	Secondary	Signals, Stop Sign, Roundabout	Partial Control (3)
Minor Collector	1,000-2,000	Secondary	Primary	Stop Sign, Roundabout	None
Local Road (4)	1,000 or Less	Secondary	Primary	Stop Sign, Roundabout	None
Scenic Roadway	Varies	Varies	Varies	Stop Sign, Roundabout	Partial or No Control

**Notes:**

- (1) Control of Access – The condition where the right of abutting owners to access in connection with a highway is fully or partially controlled by public authority.
- (2) Full Access Control – The authority is exercised to give preference to through traffic by providing access connections with selected public roads only by prohibiting crossing at grade or direct private driveway connections.
- (3) Partial Access Control – The authority to control access is exercised to give preference to through traffic to a degree that, in connections with selected public roads there may be some crossings at grade and some private driveway connections. A highway with partial access control has the same characteristics but includes some control of access along all or most of the length but lacks the complete grade separation treatment.
- (4) Local Roads consist of Access Place, Access Street, or Cul-de-sac Roads.

\* This table is to be used as a guide for design purposes but not as a means for classifying roads. Classification shall be established by function as defined in the General Plan. Reference Table 2.01 for related design criteria.

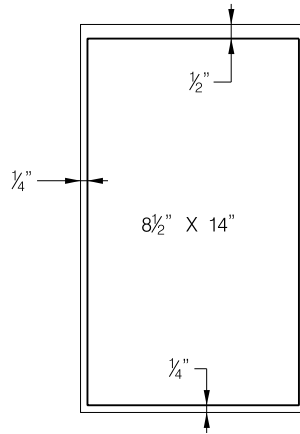

8-1/2" X 14" SHEET FOR RIGHT-OF-WAY AND EASEMENT PLATS ONLY.

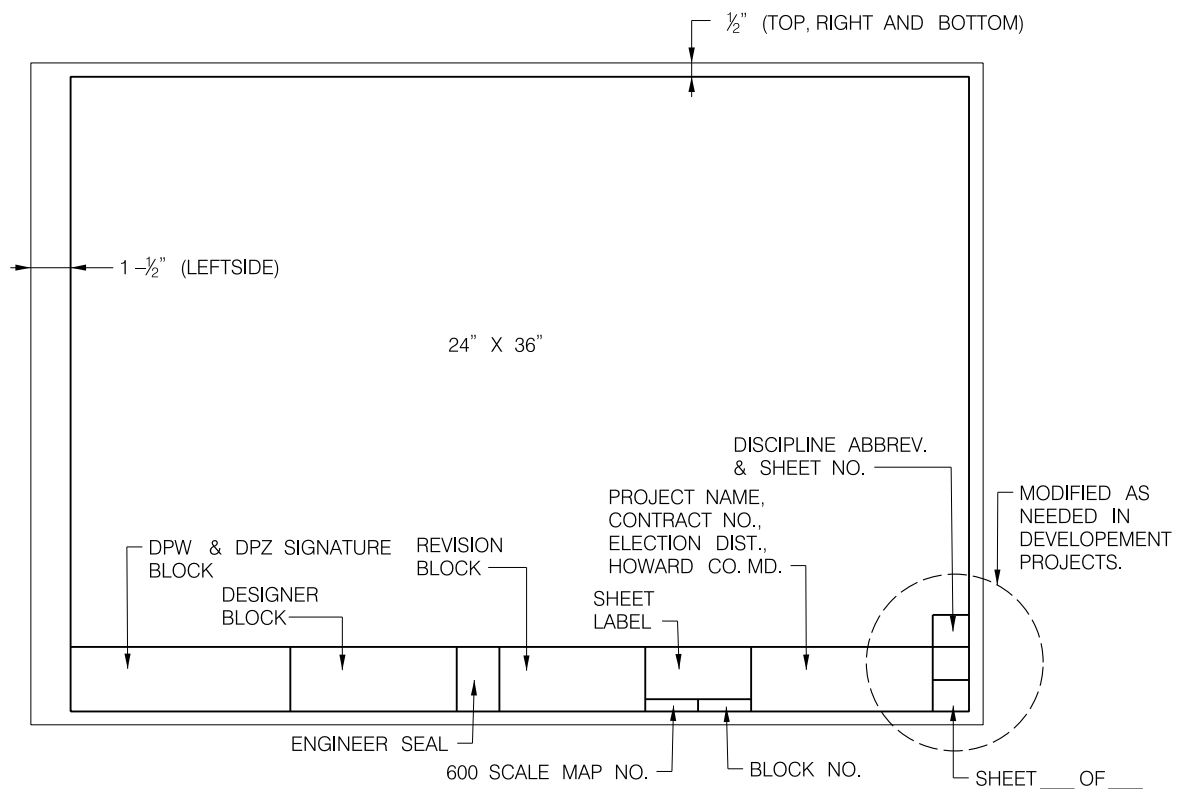

24" X 36" STANDARD SHEET SIZE FOR ALL DRAWINGS

**NOTES:**

ALL DESIGN DRAWINGS COVERED IN THESE STANDARDS SHALL BE ORIGINAL DRAWINGS SUBMITTED ON POLYESTER DRAFTING FILM (MINIMUM THICKNESS 0.004 INCHES) OF THE SIZES INDICATED ABOVE. THE DIMENSIONS SHOWN ARE THE OVERALL DIMENSIONS OF THE DRAWINGS. MATERIAL NOT FURNISHED BY DEPARTMENT OF PUBLIC WORKS. TITLE BLOCK SHALL BE SHOWN IN AREA AS OUTLINED ABOVE.

APPENDIX B

HOWARD COUNTY, MARYLAND  
DEPARTMENT OF PUBLIC WORKS

STANDARD REFERENCE  
PLAN

DRAWN BY:	WRA
CHECKED BY:	WRA
SCALE:	NO SCALE
DEC. 2017	



## Howard County Complete Streets Policy

### - As Adopted 10/7/19 By Council Resolution 120-2019

#### 1. Vision

*“To ensure that Howard County is a place for individuals of all backgrounds to live and travel freely, safely, and comfortably, public and private roadways in Howard County shall be safe and convenient for residents of all ages and abilities who travel by foot, bicycle, public transportation or automobile, ensuring sustainable communities Countywide.” - Council Resolution 35-2016.*

#### 2. Scope

The scope of this policy covers every transportation project, whether new or retrofit, capital improvement, or subdivision and land development. Certain operations, repair, and maintenance activities also create an opportunity for safer, more accessible streets for users of all ages and abilities, who walk, bike, take the bus, and drive cars, motorcycles, and trucks. Project phases within the scope of the policy include: planning, programming, design, land acquisition and rights of way, construction engineering, construction and reconstruction.

Provision of temporary accommodations during periods of facility disturbance must also be considered. Capital projects in the early stages of design will be included if possible. If opportunities arise for Complete Streets improvements to be incorporated into projects that have another primary purpose, the scale of Complete Streets improvements should be appropriate to the scale of the project. The Design Manual will provide guidance on the appropriate scale of improvements. County operations and maintenance procedures must take into account the needs of all street users. Emergency repairs and similar situations that require an immediate response are excluded from this policy.

The continuous, connected network of Complete Streets that will result from this policy will have significant benefits for the residents of Howard County, including improved safety, more travel options, reduced transportation costs, improved access to goods and services, enhanced equity, and even better health.

#### 3. Exceptions

Complete Streets improvements may not be appropriate in some cases due to the context. There are different exception processes for capital projects and developer projects.

For capital projects within the scope of this policy, exceptions to this policy shall be reviewed and approved unanimously by the Director of Public Works, the Director of Planning and Zoning, and the Administrator of the Office of Transportation or their designees. When a Complete Streets exception is being considered for a particular project, public notice, including a description of the project and the reason for the exception, shall be given through the Office of Transportation website. The Multimodal Transportation Board shall be given the opportunity to offer an advisory opinion before an exception is granted.

For development projects, exceptions will be considered using the development review process, which provides opportunities for technical review and public input.

Exceptions may be considered for approval when the project (either capital or developer) involves:

- i. An accommodation that is not necessary on corridors where specific user groups are prohibited;
- ii. A justifiable absence of current and future need exists and is not recommended in any existing planning documents;
- iii. A project of equivalent scope and schedule exists or is already programmed for funding within the next five years to provide connectivity for all users; or
- iv. Cost of accommodation or degree of impact is grossly disproportionate to the need or probable use.

#### **4. Conflicting or Competing Needs**

When there are conflicting needs among users and/or modes, safety shall be the highest priority; particularly safety for the most vulnerable street users (pedestrians, bicyclists, children, seniors, and people with additional accessibility needs). Selection and quantitative weighting of performance measures shall also support investment in the most underinvested and underserved communities.

Motor vehicle speed, flow, and driver convenience shall not be prioritized over safety for vulnerable street users. Reducing excessive motor vehicle speeds on streets where vulnerable users are likely will be considered a net benefit to the community.

To the extent that current code allows, when space is a limiting factor and where vulnerable users are likely, allocating space to a mode that is not currently accommodated shall be prioritized over providing additional space to a mode that is already accommodated.

#### **5. Creating a network**

To connect people to the places they want to go, the entire trip should be safe and comfortable. This requires a seamless, connected street network, regardless of mode, including safe and convenient pedestrian crossings and access to transit. Even a small interruption in the connection or one hazardous section can make a trip challenging.

Every street does not necessarily need to provide separate accommodations for every mode, but a network should be in place so that likely trips can be made by walking, biking, and taking public transit, as well as driving. The street network is also complemented by pathway connections in many locations.

The County shall require developers to implement Complete Streets as per this policy. Furthermore, the County shall work proactively with the State of Maryland, neighboring communities and counties, and businesses and educational institutions to develop plans, facilities, and accommodations that further the County's Complete Streets policy. Such coordination should result in continuing such infrastructure beyond the County's borders to the extent feasible.

## **6. Coordination and Engagement**

Many organizations, agencies, and entities have a role to play in implementing Complete Streets. Coordination and commitment from all agencies involved are required for success. Howard County is committed to being a leader in this effort. Some of the groups involved include:

- Howard County Government
- Howard County Public School System
- Community associations
- State Highway Administration
- Developers
- Property owners
- Engineering companies
- Construction contractors
- Advisory groups such as the Multimodal Transportation Board and Public Works Board
- Advocacy groups
- Groups working with those with limited English proficiency

Community engagement is also essential to the success of Complete Streets, particularly in the planning and design phases. Regular engagement should occur prior to the planning and design of specific capital projects. For each capital project within the scope of this policy, input shall be sought from affected stakeholders prior to setting the scope and budget of the project.

Furthermore, resources should be allocated to proactive efforts to interact with the community to identify and communicate their experience regarding existing transportation facilities and identify areas of need and opportunity. At a minimum, this should be tied to the annual Complete Streets report or preparation of the County's MDOT priority letter. Local meetings or other opportunities for input should provide easy access for all members of the community.

Different types of projects benefit from different types of public engagement. Therefore, specific procedures for initiating public engagement, focusing on traditionally disenfranchised and underserved communities, shall be developed and made available to the public on the County website by agencies responsible for implementation of this policy within 12 months of County Council's vote to approve this policy.

## **7. Design Guidelines**

This policy shall provide the policy context, themes and tone for Howard County Design Manual Volume III, Complete Streets and Bridges. Design of Complete Streets in Howard County shall draw on established state of the art street design guidelines including but not limited to national guidance from the Federal Highway Administration (FHWA), the American Association of State Highway and Transportation Officials (AASHTO), and the National Association of City Transportation Officials (NACTO). In addition to reliance on established street design guidelines, the design of Complete Streets in Howard County will be flexible and responsive to the evolving nature of transportation needs and innovation in design practice.

## **8. Context Sensitivity**

Context sensitivity allows for flexible evaluation of the community's needs with respect to existing streets and planned land use. The level of improvements should take into consideration the classification of the existing roadway as defined in the Design Manual, adjacent land use, type of community, and plans and guidelines, in particular, The Howard County General Plan. Improvements should consider the scale and character of the community and strive for connectivity between communities based on the expected transportation needs.

Context sensitivity also reflects the desires of communities affected by implementation of transportation improvements. At the planning phase of a capital project, before scope and budget are finalized, the County will obtain public input to identify transportation needs related to all modes of travel. Input will explicitly be sought from traditionally underrepresented populations in the project area. Unintended consequences to those populations, including potential gentrification and/or involuntary displacement, will be considered and mitigated.

## **9. Performance Measures**

Performance measures shall be used to track Complete Streets implementation progress, prioritize projects, and evaluate designs. *Evaluating Complete Streets Projects: A Guide for Practitioners* by AARP, Smart Growth America, and the National Complete Streets Coalition provides guidance for municipalities implementing Complete Streets policies. The performance measures listed below fit into several categories as listed in the guide and prioritized by Howard County stakeholders: access, equity/safety (tied), public health, place, and economy. Specific measures for each goal were evaluated by the Complete Streets Implementation Team in consideration of stakeholder feedback, staff feedback, and measurability.

The Complete Streets Implementation Team, in conjunction with the Office of Transportation, shall maintain a publicly-available list of performance measures on the County website and prepare an annual report documenting the County's progress with respect to these performance measures as described in Section 10 of this policy. The following performance measures shall be used:

- Safety/Public Health: Number and location of fatalities by road type and mode of travel, and by age and gender as data are available
- Safety/Public Health: Number and location of serious injuries by road type and mode of travel, and by age and gender as data are available
- Access: Miles of sidewalk, trail, and bicycle infrastructure installed or repaired
- Access: Number of curb ramps installed or repaired
- Access: Number of crosswalks installed or repaired
- Access: Number of transit stops with sidewalk access installed or repaired
- Access: Percentage of transit stops with marked crosswalks within 150 feet
- Access: Percent of Bike Howard short term network completed
- Access: Percent of Walk Howard network completed
- Access: Percent of the population with direct access to a low-stress bike network
- Access/Place: Connections to important destinations, including schools, libraries, parks, community centers, village centers, social service centers, significant health care facilities, and government centers
- Access/Economy: Connections to employment centers
- Equity: Percentage of new roadway projects or roadway repairs in priority communities

Equity shall be incorporated into every performance measure listed above to the extent data are available. Equity will be measured using the Vulnerable Population Index method, a system developed by the Baltimore Metropolitan Council which is compliant with the requirements of Title VI of the Civil Rights Act of 1964 and Executive Order 12898, "Federal Actions to Address Environmental Justice in Minority and Low-Income Populations."

The Vulnerable Population Index uses U.S. Census Bureau data to measure the percentages of the following population groups in each census tract:

- Poverty
- Non-Hispanic, Non-White
- Hispanic
- Limited English Proficiency (LEP)
- Disabled
- Elderly
- Carless

When the percent of the seven population groups in each census tract is higher than the County mean, this tract is counted as vulnerable. Tracts with even greater disparity receive additional weight. Data from each group is combined to create a composite score to measure the degree to which each tract is vulnerable.

Priority shall be given to projects in census tracts that are within the top 20-25 percent of scores on the Howard County Vulnerable Population Index.

## **10. Implementation**

**Responsibility:** It shall be the responsibility of the Office of Transportation to convene a Complete Streets Implementation Team, consisting of an equal number of internal and external stakeholders, to guide and track implementation of this policy. Initial composition of the Team shall be determined within 60 days of County Council's vote to approve this policy.

**Update of Regulations, Standards, and Plans:** The County shall incorporate this policy into all county-developed land use and transportation plans and policies.

The County shall review this policy every five years to ensure the policy is in line with current best practices.

The County shall establish a routine process for project delivery that reflects the Complete Streets policy. The Department of Public Works, Department of Planning and Zoning, Office of Transportation, and all other relevant County departments and agencies will review, seek and incorporate public input and amend current design standards, including the Design Manual and the portions of the Subdivision and Land Development Regulations that apply to roadway and bridge construction or reconstruction, to ensure that they reflect the best available standards and effectively implement this policy. Updates to the Design Manual shall be finalized by the County Executive and submitted to Council within 24 months of County Council's vote to approve this policy. The County will issue interim updates to design guidance while the Design Manual is being updated.

The County shall review Subdivision and Land Development Regulations concurrently with the Design Manual updates. The County shall make recommended updates to the Regulations, including public engagement procedures, as soon as possible but not more than 9 months after the Design Manual is updated.

**Establishing Priority Projects:** Projects shall be prioritized quantitatively on an annual basis using the project performance measures listed in this policy. The County shall establish a detailed project prioritization process within 12 months of the County Council's vote to approve this policy.

**Education and Training:** The County shall provide training to all staff in all County departments who are responsible for site and road improvements on the content of this policy and the County's new standards for using the policy for project development and review. Training shall also be provided for staff who are responsible for street maintenance and operations to offer an understanding of how maintenance and operations activities affect the experience of all street users. The County shall also encourage staff professional development and training on non-motorized transportation issues through attending conferences, classes, seminars and workshops, as appropriate.

The County shall provide training to citizens serving on relevant boards and commissions on the content of this policy and best practices for implementing the policy. Education for the public on Complete Streets concepts, the policy, and the implementation process shall also be provided. Demonstration projects can be used as educational opportunities to build familiarity with new street designs.

The County shall provide educational opportunities to developers, civil engineering firms, land use attorneys, and similar parties to understand the policy and subsequent changes to regulations, standards, and plans.

**Tracking and Reporting:** Tracking progress with Complete Streets project implementation will facilitate coordination and transparency. The Office of Transportation – with the support of the Complete Streets Implementation Team, the Department of Public Works, and the Department of Planning and Zoning – shall track and document progress made in implementing this policy in the form of a semiannual report. The annual report shall include:

- Progress made on each performance measure during the previous year;
- Public engagement undertaken;
- A description of the Complete Streets related education or training undertaken by the County;
- Exceptions granted to incorporating Complete Streets into transportation projects, citing specific reasons; and
- The measures listed below:
  - Journey to work by mode
  - Percentage of urban/suburban roadway mileage with sidewalks on one or both sides
  - Transit ridership
  - Number (or percentage) of students within the recognized Howard County Public School walk zones (safe walk or bike route to school within the minimum distance set by HCPSS)



**Communication:** Project plans and objectives shall be clearly communicated to stakeholders and the public at large. As more fully described in Section 6 of this policy, the public shall be given ample opportunity to provide input to the annual tracking and reporting process for the policy as a whole, as well as to capital projects before scopes and budgets are set. The Department of Public Works, the Department of Planning and Zoning, and the Office of Transportation shall develop department-specific outreach procedures and present them at a monthly meeting of County Council within 12 months of County Council’s vote to approve this policy.

**Maintenance:** Transportation facilities shall be maintained until they are decommissioned or replaced. All forms of transportation shall be equitably maintained, including during times of repair, upkeep or construction. “Maintenance of traffic” shall be applied to all modes. To the extent possible, maintenance of facilities for one mode should not disadvantage another.

The County shall update or establish maintenance procedures as follows:

- Roads and streets shall be kept clear of debris through regular sweeping.
- Spot repair shall keep surfaces smooth and manholes or access covers flush with the pavement.
- Snow plowing should, to the extent that conditions allow, keep sidewalks, bicycle facilities, and bus stops clear of snow.
- Property owner responsibilities to keep sidewalks passable should be enforced.

**Funding sources:** Funding for construction, operations, and maintenance is expected to come from a variety of areas including County budgets, developer projects, state, federal and other grants.

## **11. Conclusion**

A Complete Streets approach will make the street network safer and more convenient for those who drive, bicycle, walk, or take the bus – improving quality of life and making Howard County a better and more equitable place to live, work, and play.

# Community Engagement Plan for Transportation Projects



# Contents

<b>How to use this document</b>	1
<b>What is community engagement?</b>	2
Why Now?	4
Entities & Acronyms	5
Department of County Administration	5
County Council	5
Office of Transportation (OoT)	5
Department of Public Works (DPW)	6
Department of Planning and Zoning (DPZ)	6
Complete Streets Implementation Team (CSIT)	6
<b>Why is engagement important?</b>	7
Vision	7
Guiding Principles	7
Goals, Objectives, & Performance Measures	8
<b>Who is the community?</b>	10
General Public	10
Importance of Diversity, Equity, and Inclusion	11
Community Stakeholders	13
Vulnerable Population	14
Neighborhood Population	15
Project Adjacent Population	15
Community Organizations	15
Advocates	16
<b>How do we engage the community?</b>	17
A Note on Online Engagement	17
Methods of Communication	18
Email	18
Social Media	18
First-Class Mail	18
Newspaper Notices	18
On-Site Signage	18
Via Community Stakeholders	18
Communication Format	19
Collecting Public Feedback	22
Events	22
Tools	23

<b>How do we make decisions?</b>	24
Transportation Planning	24
County Capital Transportation Projects	25
Major Capital Projects	26
Minor Capital Projects	26
Private Development Projects	30
Development Technical Review	30
Major Subdivisions and Commercial Site Development Plans	30
<b>Citizen’s Guide to Community Engagement</b>	32

## Figures

Figure 1. Spectrum of public engagement, adapted from the International Association for Public Participation	2
Figure 2. Opportunity curve for meaningful stakeholder engagement	3
Figure 3. Community engagement decision making flowchart	3
Figure 4. Community Engagement Plan guiding principles	7
Figure 5. Equality vs. Equity from the Robert Wood Johnson Foundation Achieving Health Equity Collection	11
Figure 6. Howard County demographics	12
Figure 7. Defining community stakeholders, adopted from the Collective Impact Forum Community Engagement Toolkit	13
Figure 8. Howard County Equity Emphasis Area	14
Figure 9. Community engagement events	22
Figure 10. Complexity of decision matrix for designating a project major or minor for purposes of public engagement, adapted from Hurley-Franks Associates, 2009	25
Figure 11. Overview of public engagement process for major and minor capital projects	27
Figure 12. Detailed public engagement process for major and minor capital projects	28
Figure 13. Public engagement process for private development projects	31

## Appendices

Appendix A: Stakeholder List
Appendix B: Project Prioritization and Funding Checklists
Appendix C: Major Capital Project Checklists
Appendix D: Minor Capital Project Checklists
Appendix E: Private Development Project Checklists



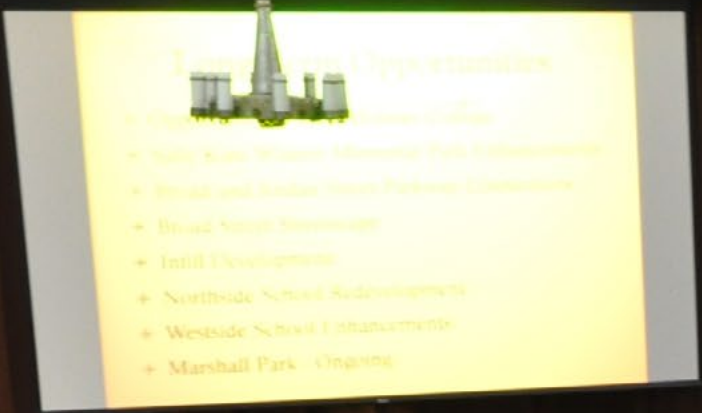

- ### City Opportunities
- + City Center Redevelopment
  - + Valley View Station - Mountain Park Redevelopment
  - + Broad and Jordan Street Parking Expansion
  - + Broad Street Renovation
  - + Infill Developments
  - + Northside School Redevelopment
  - + Westside School Enhancements
  - + Marshall Park - Ongoing



# How to use this document

This plan presents a community engagement approach for transportation projects as required by the Howard County Complete Streets policy. It is intended to illustrate procedures for how Howard County employees and others involved in development of transportation projects will engage with the general public in the transportation project development process.

These resources should be used in support of the requirements detailed in the Subdivision and Land Development Regulations, the Howard County Design Manual, and the Complete Streets policy.

This plan consists of the following sections:

## **What is community engagement?**

This section provides background on the Howard County Complete Streets policy, explains what community engagement is, and lists the public entities who are involved with the transportation decision making process.

## **Why is engagement important?**

This section sets out the vision and guiding principles that guide the County's community engagement process and explains why engagement is important. It also sets out the goals for the process, along with objectives and performance measures that will be used to gauge the County's success in achieving those goals.

## **Who is the community?**

This section defines what community means in the context of the community engagement process. It explains the importance of striving for diversity, equity, and inclusion throughout engagement, and explains how to identify community stakeholders.

## **How do we engage the community?**

This section outlines methods of communicating with the community as well as tools that will be used to interact with the community and collect public feedback.

## **How do we make decisions?**

This section outlines a typical project development process and highlights the decision points where community input is critical. It suggests what tools may make sense to use during different steps of the process. County staff is responsible for making the final decision about a design after considering public feedback and technical analysis.

## **Citizen's Guide to Community Engagement**

This section provides a guide for residents and other stakeholders to engage with Howard County transportation projects.



# What is community engagement?

Equitable community engagement is essential to the success of Complete Streets, particularly in the planning and design phases when decisions are being made. Howard County's goal for community engagement is to enable people who are affected by transportation projects, particularly groups that have been historically disinvested, to play a meaningful role in the planning and decisions about transportation projects that impact their lives. Striving for equity in engagement requires acknowledging that everyone does not start at the same place, and some people may need different resources to meaningfully participate the transportation planning process. Howard County staff should take every opportunity to create positive relationships with all members of the community affected by a transportation project.

Successful community engagement requires using a variety of techniques and tools because the public consists of a wide range of people who travel using different modes, have different perspectives and life experiences, and prefer different ways to communicate. Additionally, different types of information and feedback are necessary at different points of transportation project development. Sometimes the need for public input is limited, and at other times it is critical to determine the overall direction of a project.

Community engagement occurs on a spectrum, ranging from relatively low levels of engagement to high levels of engagement, as depicted in Figure 1.

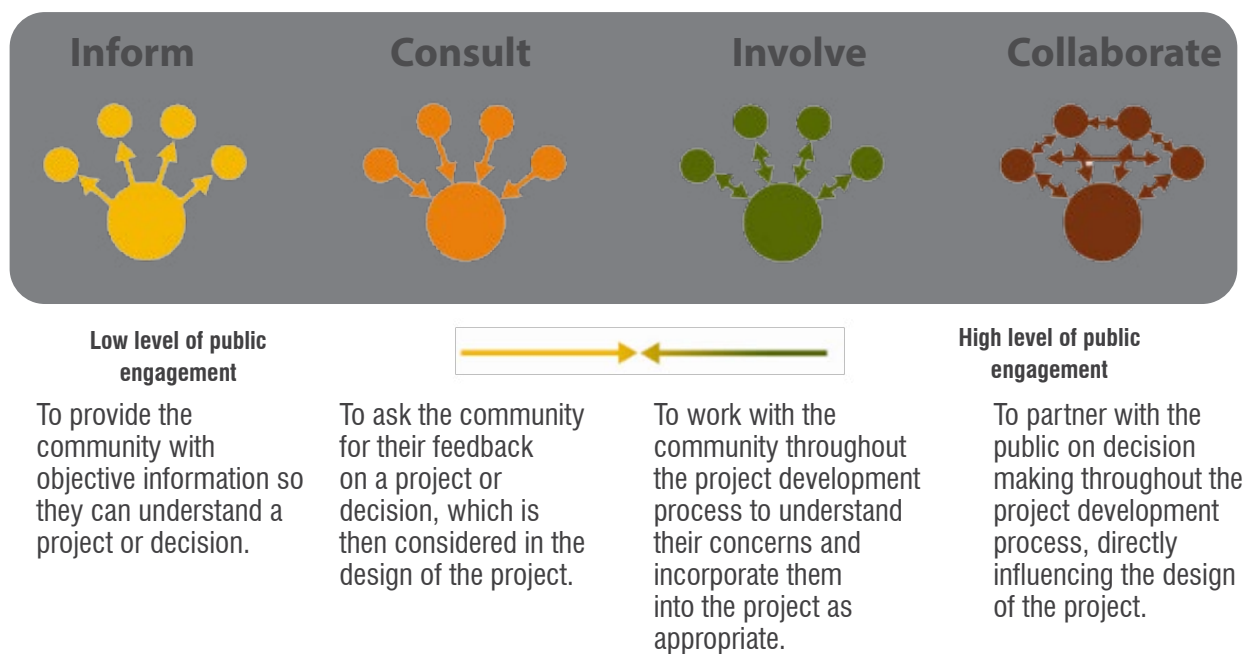

Figure 1: Spectrum of public engagement, adapted from the International Association for Public Participation

Most transportation projects go through a multi-step project development process that includes:

- Project initiation,
- Planning,
- Design, and:
- Plans, specifications, and estimate (PS&E), or final documents for bidding and construction.

Decisions made at early stages of the process are built upon in subsequent stages. For that reason, the opportunity for a high level of community engagement tends to be higher at the beginning of the project development process and decreases as the process goes on and decisions are made, as reflected by the chart in Figure 2.

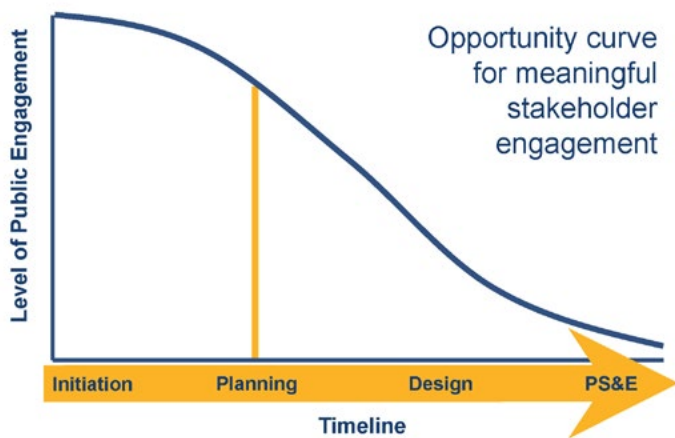

Figure 2. Opportunity curve for meaningful stakeholder engagement

The correct type of community engagement may depend upon the size and scope of the project and the extent to which decisions are informed by technical analysis and the Howard County Design Manual. When selecting the appropriate form of engagement for a project, consider the flowchart in Figure 3.

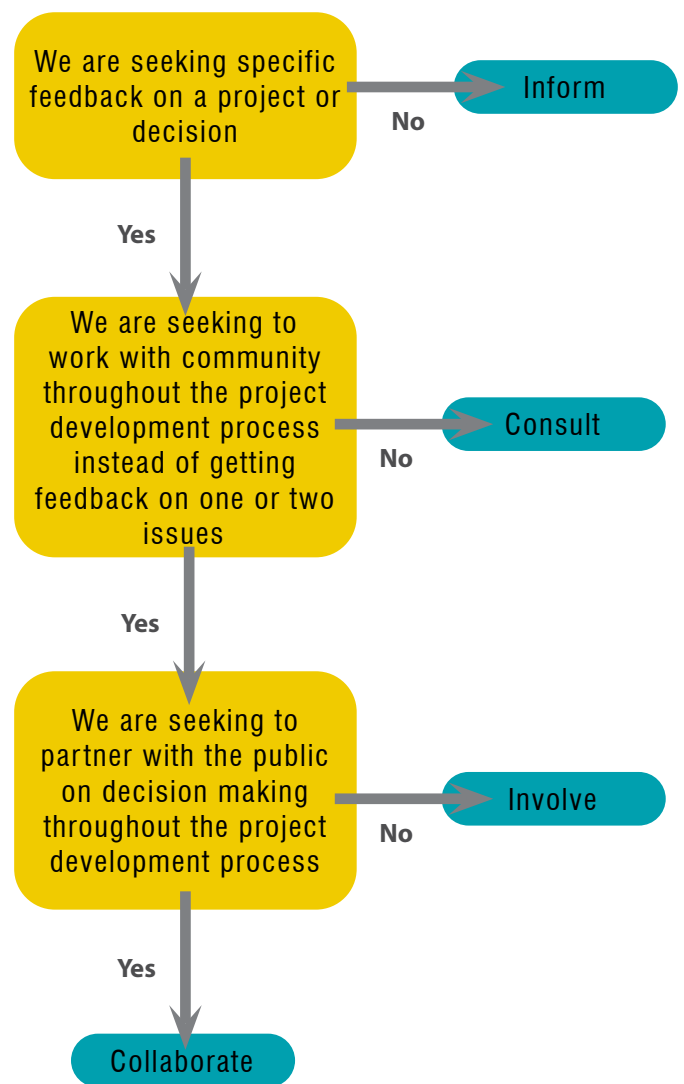

Figure 3. Community engagement decision-making flowchart

## WHY NOW?

Howard County Council adopted a Complete Streets policy, Council Resolution 120-2019, on October 7, 2019. It states that "To ensure that Howard County is a place for individuals of all backgrounds to live and travel freely, safely, and comfortably, public and private roadways in Howard County shall be safe and convenient for residents of all ages and abilities who travel by foot, bicycle, public transportation or automobile."

Section 6 of the Complete Streets policy, Coordination and Engagement, identifies community engagement as essential to the success of Complete Streets, particularly in the planning and design phases of transportation projects. The policy also acknowledges that different types of projects benefit from different types of public engagement and calls for the development of specific procedures for initiating public engagement, focusing on traditionally disenfranchised and underserved communities.

The processes and procedures outlined in this document only apply to County- and developer-led\* transportation projects in Howard County. Although they do not apply to State-led transportation projects in the County, the County will work closely with the Maryland Department of Transportation to ensure that the goals of Complete Streets are addressed by State projects.

Community engagement with the project identification and prioritization phases is discussed in this document. Public engagement with project identification is primarily handled by the transportation master planning process, which resulted in WalkHoward and BikeHoward. Project prioritization is addressed in the Transportation Improvement Prioritization System (TIPS).





## ENTITIES & ACRONYMS

Multiple Howard County governmental entities are involved with the initiation, planning, design, construction, and maintenance of the County's transportation network. A description of the role of those entities and the acronyms used to refer to them is provided below.

### **Department of County Administration**

The Department of County Administration fosters interdepartmental coordination and provides day-to-day administrative and technical support to ensure efficient operation of government and effective use of tax dollars in delivering services. The Department is responsible for the annual preparation of an operating and capital budget for the review and approval by the County Council.

- The operating budget provides funding and appropriation for the day-to-day operation of all County public services provided to residents and businesses. This includes: annual County appropriation to education entities including Howard County Public School System (HCPSS); funding of County employee salaries and benefits, contractual services, and supplies and equipment for various day-to-day services; and principal and interest payments for existing and new loans borrowed to finance public infrastructure (capital projects).
- The capital budget provides funding and appropriation for the construction or acquisition of physical assets and covers many different projects, from construction of schools, libraries, and roads to renovations of recreation centers and bridges. Capital projects are primarily funded through issuing debt, typically 20-year General Obligation bonds, with annual principal and interest payments paid from the operating budget (similar to a home mortgage).

### **County Council**

The County Council consists of five members who serve four-year terms. Since 1986, County Council members have been elected from five separate districts. There is a three-term limit for Council members. The elected members of the Council serve as the County's legislative branch, Zoning Board, and Liquor Board. They also provide constituent services for residents in their districts. County Council also reviews, provides public comment opportunities, discusses, and endorses the County's annual operating and capital budgets.

### **Office of Transportation (OoT)**

The Office of Transportation's primary focus is to increase the efficiency and effectiveness of public transit, walking, bicycling, and micromobility transportation services in and around Howard County and to ensure that connectivity is front and center in land use planning and site development. OoT also staffs the Multimodal Transportation Board, the Bicycle Advisory Group, and Transit and Pedestrian Advisory Group, which are comprised of members of the public that represent multiple areas of expertise.

#### ***Multimodal Transportation Board (MTB)***

The Howard County Multimodal Transportation Board shall: Initiate, advise, encourage, and assist in providing a safe, well-connected, equitable and sustainable transportation network for Howard County residents, businesses, and visitors, including, but not limited to: Public transit, including fixed-route, paratransit, or micromobility; Active transportation, including bicycle and pedestrian transportation; Road networks that safely promote all modes of transportation; Transportation demand management; and ADA compliance and underserved populations.

#### ***Bicycle Advisory Group***

The Bicycle Advisory Group advises the County Executive and County Administration on matters of bicycle transportation, particularly the implementation of the Bicycle Master Plan.

Public Works.

## **Department of Public Works (DPW)**

Howard County Department of Public Works is composed of the Director's Office, Bureau of Engineering, Bureau of Environmental Services, Bureau of Facilities, Bureau of Highways, and Bureau of Utilities. The Bureau of Highways and Bureau of Engineering are both involved with transportation infrastructure.

- The Bureau of Highways is responsible for addressing issues concerning pavement, sidewalks, storm drains, and trees along more than 1,000 miles of County roads for the convenience and safety of the public. This work includes preservation efforts such as road crack-sealing and tree trimming, and remedial efforts such as County road snow removal and filling potholes.
- From concept to construction, the Bureau of Engineering is committed to quality project management of Howard County's Capital Improvement Program. Projects include: bridges, parks, roads, sidewalks, storm drain systems, water and wastewater facilities. Their role with the developer sector includes quality control of construction methods and materials, to allow dedication of privately constructed facilities into the public system.

### ***Public Works Board***

The Public Works Board is required by Howard County Code to make recommendations to the County Executive and to the County Council relating to plans and policies on matters under the jurisdiction of the Department of Public Works. At the directive of the County Executive or by resolution by the County Council, the Board of Public Works shall review and make recommendations on any matter related to

## **Department of Planning and Zoning (DPZ)**

The Department of Planning and Zoning helps shape the growth and future of Howard County by facilitating the development of safe, healthy, equitable, connected, and sustained communities, concurrently respecting individual rights and protecting the County's natural environment, its historical integrity, and character. Among other activity, DPZ oversees the development review process, which includes reviewing private development plans for compliance with County regulations governing infrastructure, including transportation infrastructure.

### ***Planning Board***

The Planning Board makes recommendations to the County Council and the Zoning Board on all matters relating to planning and zoning in the County. They also make decisions with respect to matters pursuant to the laws, rules, regulations, and ordinances of the County, and general plan guidelines. Particularly relevant to the implementation of the Complete Streets Policy, the Planning Board makes recommendations on capital programs and capital budgets and reviews private development for compliance with County Code and planning documents.

### **Complete Streets Implementation Team (CSIT)**

The Complete Streets Implementation Team consists of an equal number of internal and external stakeholders that guide and track the implementation of Complete Streets policy. Internal stakeholders include representatives from the Howard County Executive's Office, the Office of Transportation, the Department of Public Works Highways Bureau, the Department of Public Works Engineering Bureau, the Department of Planning and Zoning, the Department of Recreation and Parks, and Howard County Council. External stakeholders include representatives from Howard County Public School Systems (HCPSS) Transportation Office, Columbia Association, Multimodal Transportation Board, Howard County General Hospital, a private sector engineer, and the Horizon Foundation.

# Why is engagement important?

## VISION

The Howard County Complete Streets Policy vision is:

- *To ensure that Howard County is a place for individuals of all backgrounds to live and travel freely, safely, and comfortably, public and private roadways in Howard County shall be safe and convenient for residents of all ages and abilities who travel by foot, bicycle, public transportation or automobile, ensuring sustainable communities Countywide.*

- Howard County Complete Streets policy passed by Council Resolution 120-2019

Howard County has identified community engagement as the best way to create a transportation network that is safe and convenient for Howard County residents, and acknowledges that:

- Community engagement during the planning and design phases of transportation projects is essential to the successful implementation of the Complete Streets policy in Howard County.

## GUIDING PRINCIPLES

Howard County pledges to act according to the guiding principles in Figure 4 during the community engagement process.



Figure 4. Community Engagement Plan guiding principles

## GOALS, OBJECTIVES, & PERFORMANCE MEASURES

Howard County will lead the community engagement process for transportation projects with the following goals and objectives in mind:

Goals	Objectives	Performance Measures
<p><i>Engagement</i></p> <p>Build relationships with community institutions representing community stakeholders to yield diverse public engagement with project development*</p> <p>*Community institutions are listed in Appendix A of this document. How to identify which community institutions should be engaged for a given project is described on page 10 of this plan.</p>	<ul style="list-style-type: none"> <li>• Consult with community institutions in advance of project scoping to gain historical perspectives and experiences with location under consideration and provide background information on project history and project development process</li> <li>• Collaborate with community to determine appropriate public engagement approach, including where and when meetings should be held and the preferred format</li> <li>• Proactively include community institution representatives on Complete Street email list and project email list for projects in their area</li> </ul>	<ul style="list-style-type: none"> <li>• Number and types of community institutions, organizations and stakeholders consulted and contacted</li> <li>• Community meeting decisions documented on project website</li> <li>• Number and types of organizations represented on Complete Streets and project specific listservs</li> </ul>
<p><i>Communications</i></p> <p>Increase awareness about Complete Streets and transportation projects among community stakeholders</p>	<ul style="list-style-type: none"> <li>• Develop messaging that resonates with community stakeholders for use across multiple platforms, including emails, websites, social media, and signage</li> <li>• Increase subscribers to Complete Streets and project specific listservs in affected communities</li> <li>• Increase social media usage to promote educational content, events, surveys, by geo-targeting community stakeholders</li> <li>• Increase online traffic annually to Howard County Complete Streets website and project specific website</li> </ul>	<ul style="list-style-type: none"> <li>• Utilize various communications channels to distribute messaging based on Community Engagement Checklists</li> <li>• Number of Complete Streets and project specific listserv subscribers; Percentage of emails opened</li> <li>• Number of social media shares, likes and comments for each post</li> <li>• Number of unique visits to Complete Streets and project specific websites</li> </ul>



<p><i>Equitable Access</i></p> <p>Provide multiple options and formats for public engagement that encourage meaningful interaction and collaboration between Howard County staff and community stakeholders</p>	<ul style="list-style-type: none"> <li>• Hold in-person and online opportunities to educate attendees and collect feedback throughout project development</li> <li>• Provide in-person and online feedback opportunities that include survey and open-ended options</li> <li>• Advertise participants can request special accommodations if they have accessibility challenges</li> <li>• Where requested, provide project materials in alternative formats for individuals with barriers to access (disability, vision, hearing, language)</li> </ul>	<ul style="list-style-type: none"> <li>• Number of people attending in-person workshops and meetings and/or participating online</li> <li>• Document and publish summary of any survey results and other feedback; note which feedback is being incorporated into the design</li> <li>• Percentage of engagement materials that include special accommodation notice</li> <li>• Track percentage of requests met for accessible project materials</li> </ul>
<p><i>Process and Outcomes</i></p> <p>Formalize internal processes, internal and external feedback loops, and ongoing community engagement</p>	<ul style="list-style-type: none"> <li>• Endorse and implement this Community Engagement Plan</li> <li>• DPW, DPZ, OoT staff, and County consultants representing the County participate in annual training in equitable public engagement and the principles supporting the Complete Streets policy</li> </ul>	<ul style="list-style-type: none"> <li>• Conduct annual review of Community Engagement Checklists to ensure completion and assess how effective engagement initiatives have been</li> <li>• Percentage of completed and published public engagement tracking sheets</li> <li>• Number of staff participating in Community Engagement annual training</li> </ul>

### Tracking and Reporting

Tracking and reporting on the above performance measures will be completed during the preparation of the Complete Streets Annual Report by the Office of Transportation as mandated by the Howard County Complete Streets policy. The reports will be used to analyze trends over time, with a goal of seeing equal or improved measures year over year. Trends that do not improve will be analyzed and strategies will be adjusted accordingly.

# WHO IS THE COMMUNITY?

The County will use a variety of communication channels to distribute information and solicit feedback about a project from community stakeholders. The methods used to communicate with the community depend on the type of stakeholder group.

The County will develop and maintain a Complete Streets Stakeholder List that includes contact information for key County institutions, homeowners associations, village boards, places of worship, schools, community organizations, and vulnerable populations. This list will be used for general outreach, and function as a starting point for project managers who are conducting outreach for a specific, geographically located project.

## GENERAL PUBLIC

Demographic and socioeconomic data provides insight into the character of Howard County and its diverse communities. By better understanding the people and places of Howard County and their unique characteristics we can better plan and provide services.

Howard County has a diverse and growing population. Located between Washington, D.C. and Baltimore, Howard County is in the heart of one of the largest regional economies in the United States. There is much activity and movement with commuters and commercial freight coming into and leaving the County every day. The diverse economy attracts jobs and industries of all types, from basic services and retail, to manufacturing and warehousing, to high-tech employment. Despite being the center of all this activity and regional growth, a large portion of Howard County remains rural, with its western half made up of low-density housing and acres of farmland and natural resources, much of which is permanently preserved. The County's eastern half consists of higher density housing, including many apartment and townhome communities, and a significant number of jobs. The diversity of housing draws a diverse population made up of many races speaking a variety of languages. Given the high quality of



its school system Howard County attracts many families with children. As a result, it has a higher proportion of families with children compared to Maryland and the nation. However, like most places around the country, Howard County's population is rapidly aging, with increasing numbers of residents living alone and with disabilities.

The 2020 Vision for Health in Howard County produced by the Horizon Foundation acknowledges this diversity, but adds, "For decades, Howard County has been known for its forward-thinking approach to creating the highest quality of life, serving as a national example of how people of diverse backgrounds can create a thriving community." As a community that strives for the best, we must also acknowledge that not everybody has the same access to the county's resources and opportunities, and inequities are evident across a variety of outcomes in Howard County, including education, health, housing, and transportation.

## IMPORTANCE OF DIVERSITY, EQUITY, AND INCLUSION

Given the diversity of Howard County, it is critical that public engagement strategies are designed with equity in mind. Striving for equity in engagement requires acknowledging that everyone does not start at the same place, and some people may need different resources to achieve the same outcome. There are persistent inequities across a variety of outcomes in the County – education, health, housing, and transportation among them – and these inequities need to be overcome. The various public engagement strategies outlined in this document are intended to ensure that everyone has the tools they need to engage in the transportation project development process in Howard County.

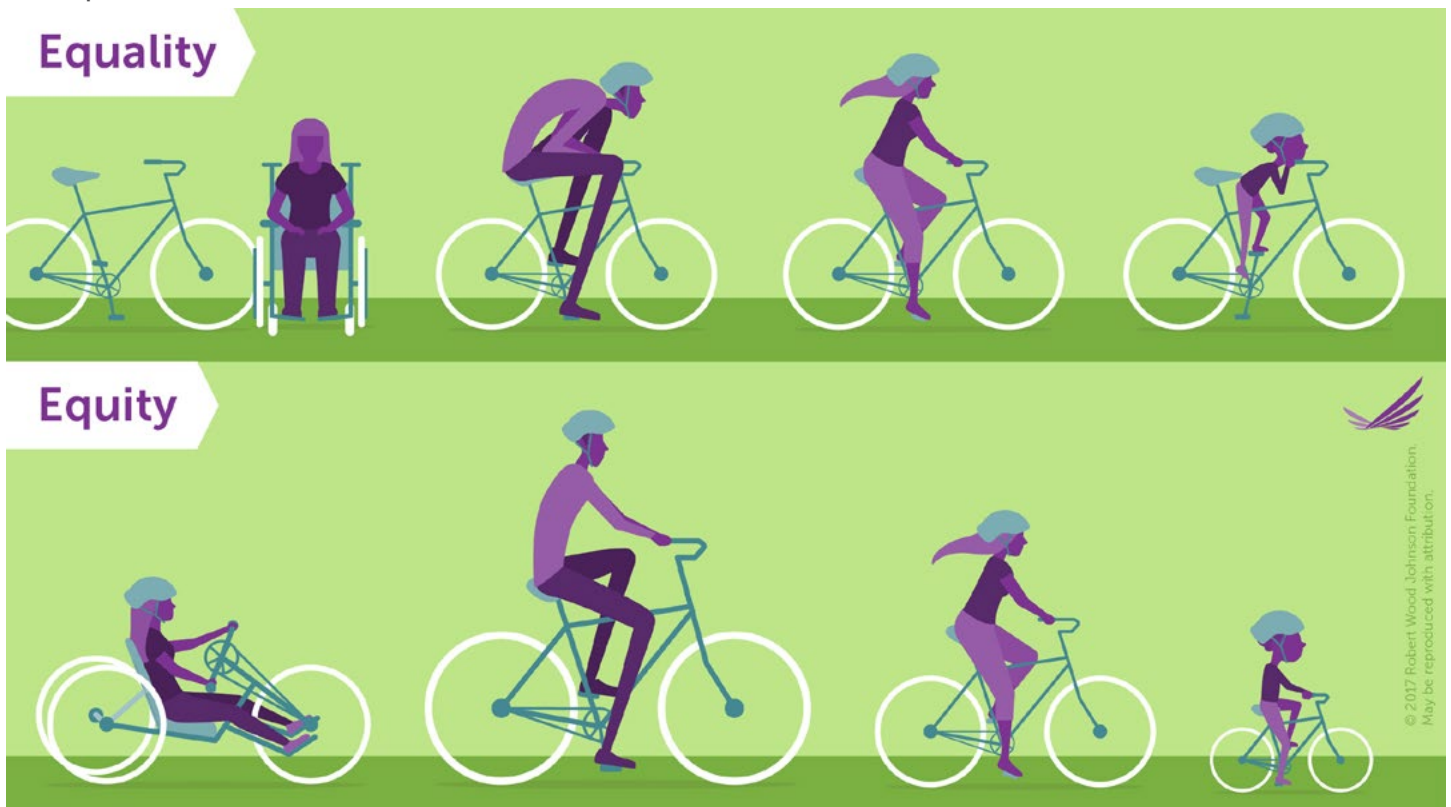
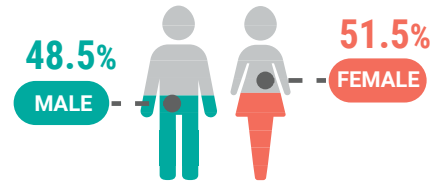
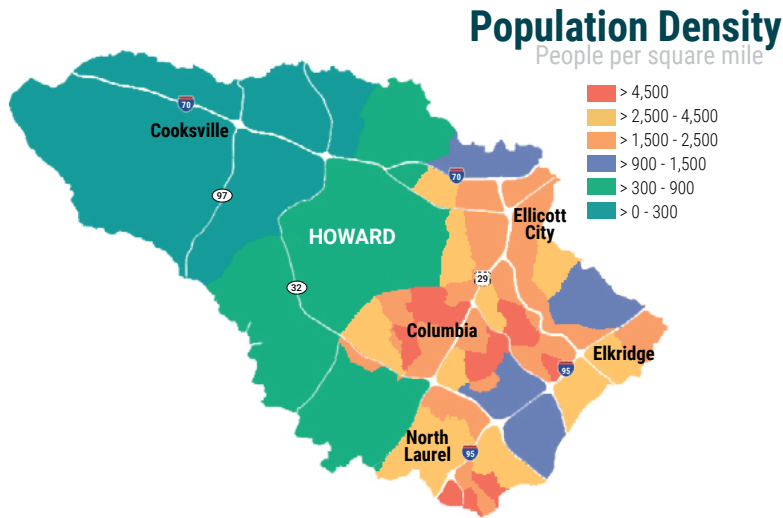

Figure 5. Equality vs. Equity from the Robert Wood Johnson Foundation Achieving Health Equity Collection



# HOWARD COUNTY DEMOGRAPHICS



### 321,100+ People of All Ages

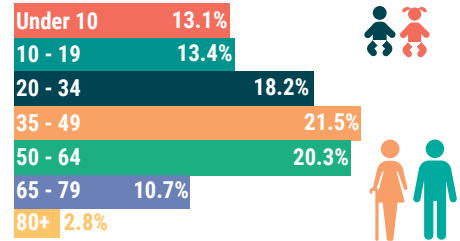

### A Diverse County

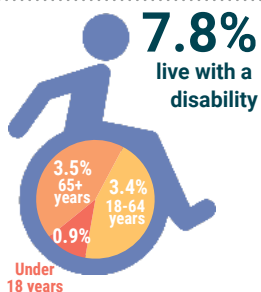
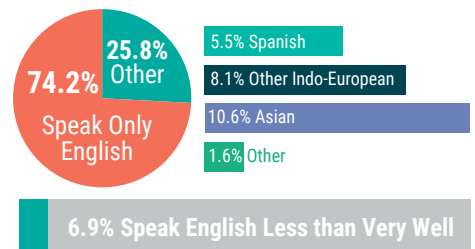
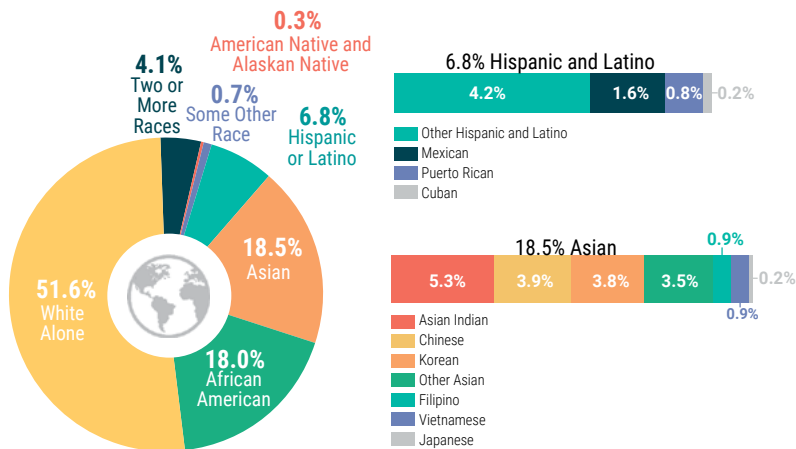

### 170,300+ Commuters

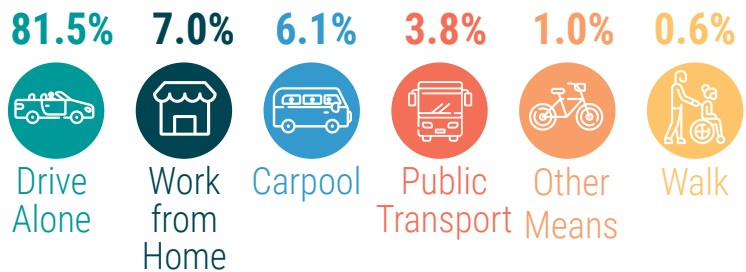

74,600+ residents work in Howard County

### 169,000 jobs in the County



Source: 2017 American Community Survey, US Census Bureau

Figure 6. Howard County demographics

## COMMUNITY STAKEHOLDERS

This section defines the different types of community stakeholders who may be interested in a Complete Streets project, or those that are affected by the project. Individuals may fall into multiple stakeholder categories. It is important to identify which stakeholders should be involved at the beginning of the project. When facing a decision on whom to include, it is best to err on the side of being more inclusive to create a comprehensive stakeholder list. The below chart provides a useful way to identify that populations that should be included in outreach efforts.

Some things to keep in mind when identifying which stakeholder perspectives are critical to the success of a project are which people:

- Will be affected by the decision, either directly or indirectly
- Would like to be engaged or are already engaged
- Can directly influence project decision-making
- Must provide support for the project to be implemented successfully
- May be concerned if they don't feel they've been heard
- Represent others who may not otherwise be heard



Figure 7. Defining community stakeholders, adopted from the Collective Impact Forum Community Engagement Toolkit

## Vulnerable Population

Equity is at the center of transportation decision making in Howard County. To ensure resources are directed toward traditionally underserved communities and those with the greatest need, the County evaluated Equity Emphasis Areas (EEA) using U.S. Census Bureau data to measure the percentages of the following population groups in each census tract:

- Low-income: as measured by the U.S. Census as "population in poverty," which is defined by a set of income thresholds that vary by household size and composition
- Hispanic: as defined by the U.S. Census as a person of Mexican, Puerto Rican, Cuban, Central or South American, or other Spanish culture or origin, regardless of race
- Non-Hispanic, Non-White: "non-white" or "minority" is defined by the U.S. Department of Transportation Order (5610.2) on Environmental Justice as Black, Asian American, Native Hawaiian or Pacific Islander, American Indian and Alaskan Native, some other race alone, and two or more races Limited English Proficiency (LEP): as defined by the U.S. Census as people aged 5 and over who speak a foreign language at home and either speak no English or speak English "not well"

- Persons with disabilities: as measured by the U.S. Census as "disabled," and defined by a person of any age whose hearing, vision, cognition or ambulation difficulties result in limitations of activities and restrictions to full participation at school, work, home, or in the community
- Older adults: as measured by the U.S. Census as "elderly," and defined by a person age 75 and above
- Carless: as defined by the U.S. Census as a household with no vehicles available

When the percent of the seven population groups in each census tract is higher than the County mean, this tract is counted as an emphasis area. Tracts with even greater disparity receive additional weight. Data from each group is combined to create a composite score to measure the degree to which each tract is emphasized. This system is being used in the project prioritization process, whereby priority shall be given to census tracts with higher EEA scores. The current assessment shown below uses American Community Survey data from 2015 5-year data. The EEA and map will be updated periodically as the United States Census releases new data.

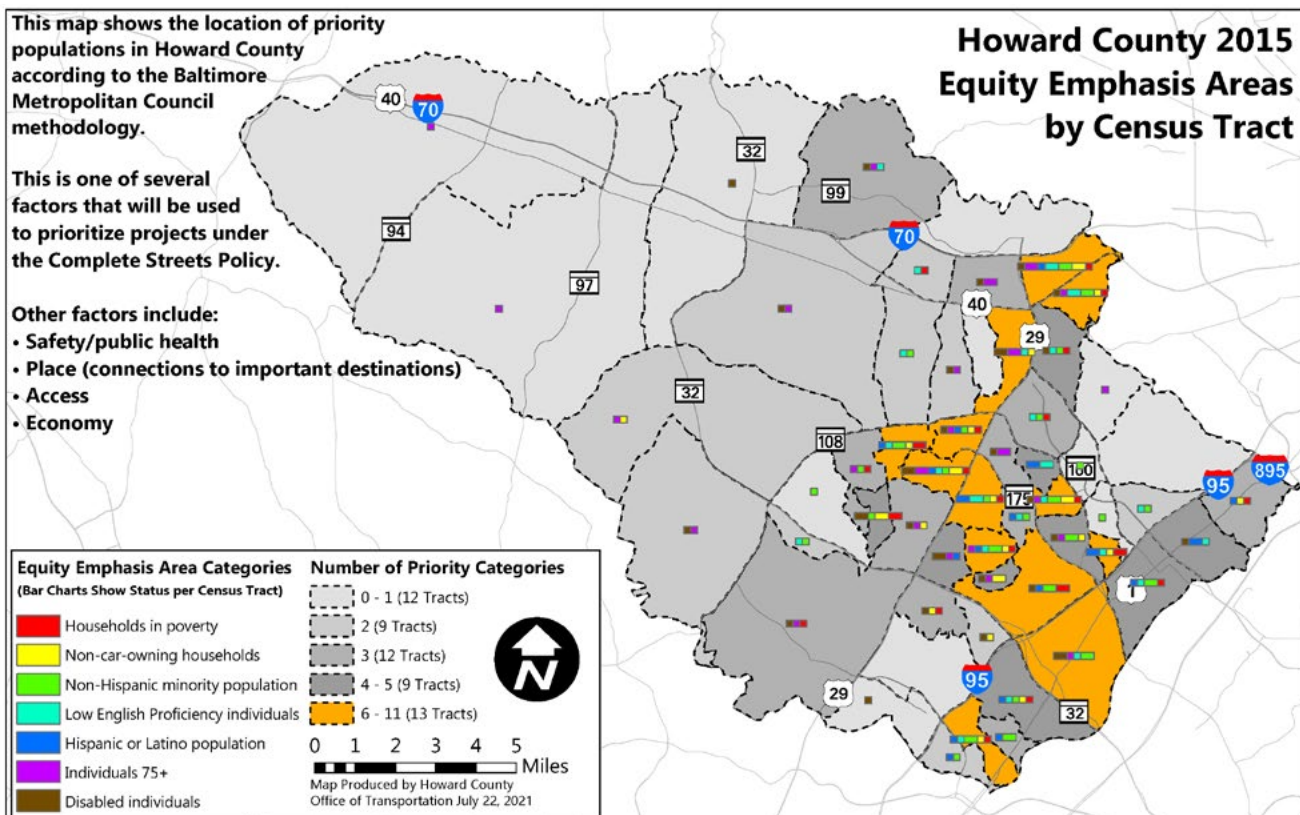

Figure 8. Howard County Equity Emphasis Area

The EEA should also be used to identify which under-resourced populations, if any, live near a proposed transportation improvement. Engaging with vulnerable populations may require different communication techniques than engaging with other stakeholder groups. Seniors may not be as comfortable utilizing technology to learn about a project or provide feedback. People with limited English proficiency may not be able to understand project information that is posted or distributed in English. People with disabilities may not be able to readily travel to attend a public meeting. Efforts should be made to identify social service organizations who work as intermediaries between Howard County government and the under-resourced population to develop an appropriate engagement approach.

### **Neighborhood Population**

People who live, work, play, or access services in a neighborhood that is slated for a transportation improvement will likely be impacted by decisions made during the project development process. This may happen either directly, as regular users of the transportation corridor, or indirectly, by changes in how their neighbors use the transportation network. Educational efforts may be necessary to help people understand the impact transportation changes have on their daily life and their community and encourage them to engage in the public engagement process. Regardless, it is important to invite people to participate and have input to the decision-making process. Often there are existing community groups, including civic associations, homeowners associations, and elected officials, that can assist with outreach to the neighborhood population.

If a project is located wholly within an established community, it may be easy to determine which organizations to contact. For projects located on the boundary of multiple communities, or projects that connect multiple communities, be sure to engage the community organizations representing each geographic area.

### **Project Adjacent Population**

People who live, work, play, or access services adjacent a corridor that is slated for transportation improvements will be directly impacted by decisions made during the project development

process. At a minimum, the construction of a project may negatively impact quality of life in the short-term. In the long-term, changing circulation patterns may alter the character of the corridor or fail to provide opportunities for transportation choices that are inherent to Complete Streets. Those living directly adjacent to the project are likely to be the most upset if they feel they do not have input to the decision making process. They may also feel they have greater standing than regular users of the corridor. It is critical that people who live or own property adjacent to the project are invited to every step of the public engagement process and informed of decisions made along the way to improve community/governmental relations to develop a transportation project that works for the local population.

### **Current and Potential Project Users**

People who are current or potential users of a corridor slated for a transportation improvement will be directly impacted by the decisions made during the project development process, even if they do not live or work in the project area. These stakeholders can offer critical input on the design of the project because they have the best understanding of the community's transportation needs and how those needs might not be currently met. Current corridor users can be reached by posting project information at the site. Post information along low-stress places to walk or bike that people currently use to travel through the area in order to reach potential users.

### **Community Organizations**

Community based stakeholders such as Village Boards, Homeowners Associations, and local service providers including places of worship, schools, cultural institutions, libraries, community centers, and non-profit organizations have extensive ties to the communities they serve and are committed to improving the quality of life for their constituents. Some community stakeholders work within specific geographic areas and some work County-wide. Community stakeholders can distribute information about transportation projects to their networks. The County should maintain a comprehensive list of community stakeholders to reference when developing stakeholder lists for specific projects. Organizations that work County-wide should receive announcements about each project regardless of location.



## **Advocates**

There are several organizations actively advocating for Complete Streets in Howard County. These groups tend to be highly engaged with transportation projects. Advocacy organizations are directly connected to people who care about transportation issues and can use their communications channels to increase participation in public engagement around transportation projects. Examples include:

### ***Streets for All in Howard County***

According to its website, “Streets for All is a coalition of 20 groups advocating for Complete Streets in Howard County. We support a robust investment in sidewalks, crosswalks, bike lanes, bus stops and other infrastructure projects. We want everyone in Howard County, no matter who they are or where they live, can feel like they can safely, easily and comfortably bike, walk or take public transportation anywhere they need to go. Advocacy for Streets for All in Howard County is led by the Horizon Foundation, AARP Maryland and the American Heart Association.”

### ***Horizon Foundation***

According to its website, “The Horizon Foundation is Howard County’s community health foundation. We are committed to improving health through innovative initiatives, collaborative partnerships, strategic grantmaking and thoughtful advocacy. Our work is driven by community needs and is shaped around strategic solutions that promise a significant lasting impact on physical and mental health in Howard County. As the largest independent health philanthropy in Maryland, we are driven to help everyone in our community – especially those facing the greatest challenges.”

### ***AARP Maryland***

AARP is a national organization whose mission is “to empower people to choose how they live as they age.” One of its nationwide initiatives is AARP Livable Communities, which, “supports the efforts of neighborhoods, towns, cities and rural areas to be great places for people of all ages. We believe that communities should provide safe, walkable streets; age-friendly housing and transportation options; access to needed services; and opportunities for residents of all ages to participate in community life.” AARP Maryland advocates for Howard County Complete Streets because Complete Streets will allow seniors to travel around their communities without relying on a personal automobile.

## ***American Heart Association***

The American Heart Association (AHA) is an international organization. The AHA has an office that serves the greater Baltimore area, including Howard County. Its mission is “to create a world free of heart disease and stroke – a world where everyone can achieve the best possible health – and it starts right here in Baltimore. That’s why we must come together to solve complex issues that effect this generation and generations to come.” One major policy area that AHA focuses on is Active Living, which is supported by transportation systems that include options for people who walk and bicycle.

### ***Bicycling Advocates of Howard County***

According to its website, “the Bicycling Advocates of Howard County (Bike HoCo) is a 501(c)4 non-profit organization founded in 2008 as a coalition of cycling clubs and bicycle riders in Howard County, Maryland. Bike HoCo advocates to improve the visibility and safety of bicycling, supports bicycling education programs for adults and children, and promotes a vision of bicycling and sharing the road as part of a healthy, energy efficient, and environmentally sound transportation system to help achieve a sustainable future for Howard County and for Maryland.”

# How do we engage the community?

After developing a comprehensive stakeholder list, the next step is to determine a reliable way to communicate with each stakeholder group. The section below discusses methods of communication, or how we reach out to the community. The following section reviews different communication formats, or what media we use.

## **A NOTE ON ONLINE ENGAGEMENT**

Historically, public engagement has been conducted mostly in person at public meetings or workshops. However, online communications and engagement opportunities are increasingly becoming important elements of the community engagement process. The Internet makes it possible to reach a broader audience and achieve higher levels of participation than traditional methods. According to Pew Research Center, as of 2021:

- 93% of adults are online
- 72% of adults use at least one social media site; and
- 85% of adults own a smart phone

Online engagement also presents new challenges. When communicating online or preparing materials for online engagement, make sure to account for:

- **Mobile compatibility:** many people will be accessing information with their cell phone or tablet
- **Language:** Translation should always be available, based on County demographics, to ensure people with limited English proficiency can provide input to the project
- **WCAG 2.0 Certification (Web Content Accessibility Guidelines):** The goal of WCAG is to provide a single shared standard that makes web content more accessible to people with disabilities
- **Privacy Protection:** Controls need to be in place to protect the personal information of

individuals who are participating in online engagement opportunities

- **Third party moderation:** If an online platform offers opportunity for interactive comment, it is important to monitor the space and moderate if necessary
- **Rich media:** Rich media includes things like audio, video, or other elements that encourage people to interact with online content
- **Technical guidance:** create a document to assist the public in how to participate in a virtual meeting

Expanding online public engagement does not mean that traditional forms of communication and engagement can or should be abandoned. Instead, both online and in-person methods should be used in tandem to ensure that all stakeholder groups are engaged throughout the project process. As project materials are developed, the County should create both print and digital versions that can be used in-person and online. All materials should include a link to the project website.

## METHODS OF COMMUNICATION

Different methods of communication can be utilized depending on the target audience. Marketing and communications attract the community to participate - whether it be a meeting, a survey or comment opportunity, or visiting the project website to learn more about the project. Whatever method of communication is used, be sure to remain in regular contact with interested stakeholders with project status updates, especially if there are challenges that impact the original project schedule. Communications will be coordinated with the County Office of Public Information.

Some common methods of communication are described below.

### Email

Email is a great way to keep stakeholders informed about a project. Most – though not all – stakeholders have ready access to email and use it frequently. It is important to collect and maintain email lists for individual projects, as well as a separate list consisting of members of the public broadly interested in transportation improvements. Some best practices for using email to communicate include:

- Use an electronic sign-in at community meetings and events to avoid mis-spellings of names or email addresses and save staff time in entering data
- Build a transportation email listserv by sharing sign-in sheets/attendance records interdepartmentally
- Send out an email to the County Complete Streets listserv at least 14 days in advance of any public meeting and a second email a day or two prior to the meeting as a reminder
- Encourage email recipients to forward information to others who may be interested in the project
- Include a link to the project website in all email correspondence, as well as a reason to click the link
- Include a clear description of the purpose of any upcoming meeting
- Include a description of benefits to the public to participation in the process
- Include contact information to facilitate request for special accommodations, assistance with access
- Send a thank you for participant's interest and participation

### Social Media

Social media platforms including Facebook and Twitter offer a way to get in touch with people who live in proximity to a proposed transportation project. Some best practices for using social media to communicate include:

- Establish a minimum radius, say one to two miles, from a prospective project location to target social media outreach and community engagement
- Begin “boosting” targeted social media posts (cost: \$30-\$50/post) at least 30 days in advance of a meeting or when feedback is due
- If engagement is low, buy digital ads featuring graphics, including gifs, memes, and other innovative media to attract interest
- Encourage community stakeholders to post or cross post project information directly from County agency social media pages

### First-Class Mail

First-class mail should only be used selectively in order to meet County Code requirements since it has not been proven to be an effective engagement technique in many jurisdictions.

### Newspaper Notices

Print and digital notices or ads in the Howard County Times or Columbia Flyer should be used selectively to advertise annual or special one-time only events. Advertisements are especially appropriate for events with a county-wide audience such as the annual Active Transportation Open House or projects that may attract users from across the County.

### On-Site Signage

Posting a sign on-site that shares project information, opportunities for input, or notice of a community meeting is a good way to reach members of the public who regularly use a corridor, especially by foot or by bicycle. Signs should be ADA compliant and posted at least 30 days ahead of meetings. Signs should be oriented and sized to ensure community members can see the signs while passing the project site.

### Via Community Stakeholders

Howard County Village Boards, Homeowners Associations, and elected officials are in regular communication with members of their community. Local service providers like places of worship, schools, cultural institutions, libraries, community centers, and non-profit organizations are also in regular communication with the populations they serve. These organizations can share project information with their constituents via emails, social media channels, in-person gatherings, and

flyers or other information posted at their facilities. County representatives should meet with community stakeholders at the start of the project development process to inform them about the project and public engagement process and learn about any existing conditions that would impact the project. County representatives should also identify which stakeholders work with the vulnerable population and meet with them to discuss and modify the public engagement strategy to ensure equitable public participation.

## **COMMUNICATION FORMAT**

Different communication formats are best suited for sharing different types of information. Communication formats can be distributed via one of the methods of communication listed above, but they can also be used during the in-person or online engagement events discussed in the next section. Selecting the right type of communication format is important because engaging content brings the community back to subsequent engagement opportunities and encourages individuals to tell their neighbors and friends to get involved in the project. Some best practices for common communication formats are included below. Communications will be coordinated with the County Office of Public Information.

### **Project Website**

A project website should document the full history of the project including any planning studies, all outreach to date, all project materials, an overview of the project schedule, an invitation to interested community members to participate in public engagement, the benefits to participation, and methods of communicating with the sponsoring department. All other project materials should include a link to the project site, with a goal of driving as much traffic to the site as possible. Larger transportation projects should have a standalone website, and smaller projects can share the same webpage. The project website will include links to digital versions of all other communication formats distributed over the course of the project.

### **Project Graphics**

Any graphics developed for the project – whether diagrams, plans, or renderings – should be easy for the general public to read and understand. Make sure nearby landmarks and streets are clearly labeled so people can orient themselves. Include figures for scale wherever possible. Cross sections are generally easier for the public to understand than plan views, so they should always accompany plan views of a project. Photorealistic or artistic renderings may be appropriate for larger projects or projects that are more difficult to understand in

section or plan.

### **Informational Video**

Sometimes, no matter how well-designed project graphics are, they may benefit from extra explanation from a project manager or other County representative. It is easy for someone to explain graphics while in person at a meeting, but that means the graphics are not as useful to someone perusing them on their own time. Consider creating short – less than two minutes – videos that explain a design. Short videos can boost online engagement, can be distributed via multiple communication channels, can be televised, and can be used at an in-person workshop to supplement conversations.

### **Project Flyer**

A well-designed project flyer with interesting graphics is a great way to advertise a project meeting or opportunity for project input. An effective flyer should include: project name, project purpose, project number, project website, date, place, time of meeting, contact information, listserv signup information, note special accommodations available, alternate way(s) to provide input, and registration link (if applicable). It should:

- Include the project website, listserv signup information, and registration link (if applicable)
- Meet accessibility standards (WCAG 2.0)
- Be easy to distribute digitally (develop pdf for email distribution and versions appropriate for social media)
- Be easy to print and distribute as a hand-out (full color and black & white versions)
- Be distributed at least 30 days in advance of scheduled event or input opportunity; send out reminders as often as weekly leading up to the event, and every couple of days the week of the event
- Include a registration link for online meeting (if applicable)

### **County Press Release**

Press releases are official communications sent to members of the news media that provide information, an official statement, or an announcement. Press releases should include media contact information, a headline, and basic information about the project including who, what, when, where, and why. Press releases are a useful tool to get information out to the general public because they are generally covered by multiple news sources, ensuring broad distribution. Press releases can be used to announce the kick-off of a large process, a public meeting, or the start or completion of construction. They should include where to find more information about the project

(project website), and how to sign up to receive regular project updates (project email listserv).

### **On-Site Signage**

On-site signage offers a way to engage people who are regular users of the transportation corridor. Traditionally, on-site signage had only been used to provide public notice of developer projects, but in 2019 the Department of Public Works began using signage to increase public awareness and participation in public meetings for capital projects. Signs are 30'x60" and yellow in color, and are required to include public meeting date, time, and location, the project number, a link to receive additional information, and a contact phone number. Signs are posted at all roadway approaches to the site.

On-site signage can also be used to solicit public input on project design or inform people of a proposal. A sign soliciting public input can be succinct, perhaps just posing a basic question and asking residents to text their response to a number.





# Rebuilding Resilience

Help and planning public spaces to be closer throughout like games, street art, other activities make the rich and making

Great City Park is a vibrant place with history, play and unique natural features. We're excited about Great City Park plans to be a place to make an exciting park for all who play and live at the park!

**Temporary Parklets**



**Other Amenities**



**Water Fountain**



**Play Park**



**Interpretation**



**Access to Water**



**Interpretation**



## COLLECTING PUBLIC FEEDBACK

When deciding which engagement process to use, it is important to consider what tactics have worked in the past, how to ensure that all voices will be heard, how community stakeholders can engage in activities, how to balance technology versus traditional approaches, and cost.

### Events

Events should be scheduled for times and at locations that are convenient and accessible for community members. An open house format where participants can attend as they are able is preferred to a format where mandatory attendance over multiple hours is required. Multiple events held at different times should also be considered to increase accessibility. Timing should consider the Howard County Public School System schedule, as well as federal and cultural holidays. Partner with key institutions in the project area to host community events and meetings. All engagement opportunities provided in-person should also be provided online in order to ensure maximum participation and accessibility. Online feedback should be given the same weight as in-person feedback when making decisions.



Figure 9. Community engagement events



## Tools

Different tools can be used to collect feedback during in-person or online engagement events. Tools can be very controlled, in that they allow limited interaction between participants, or very open, in that they can allow participants to freely engage with each other. One type of environment is not better than the other; each has value when used at the appropriate time. Some common tools and best practices for their use are included below.

### Controlled Environment

Participants cannot interact with each other. Information collected is only visible to County staff.

#### Surveys

Surveys are convenient and familiar, and allow participants to document their opinions. Structured questions ensure that project managers are getting the information they want.

#### Polls

Polls are quick and allow participants to give their response to one or two targeted questions. Participants can see aggregate poll results which can stimulate conversation around a decision.

### Mixed Environment

Participants can see the contributions from other participants, but cannot interact with each other.

#### Q&A

An open question and answer session gives the public the opportunity to ask outstanding questions. Questions can be moderated, and responses can be given publicly or privately.

#### Storytelling

Creating a forum for storytelling allows the community to better empathize with one another's transportation challenges and connect with project goals.

### Open Environment

Participants can interact with each other. All comments and ideas are visible.

#### Maps

Using maps is a great way to collect place-based feedback on issues. Participants can see where others are also having issues and begin to think creatively about solutions building off each other's ideas.

#### Idea Boards

Participants can add their ideas to a board via virtual or in-person "sticky notes". People can indicate ideas they agree with, and concepts can evolve as participants brainstorm solutions that work for the whole community.

# How do we make decisions?



The purpose of this section of the document is to explain each step of the transportation project process with a focus on when and how public engagement can impact the project design. County staff is responsible for making the final decision about a design after considering public feedback and technical analysis.

## **TRANSPORTATION PLANNING**

The Office of Transportation coordinates closely with the Department of Planning and Zoning and the Department of Public Works on several transportation planning initiatives in Howard County. Transportation plans, including WalkHoward and BikeHoward, were created with extensive community engagement.

For BikeHoward, public engagement was facilitated through six public workshops, an online survey, and an online interactive map. More than 750 people were engaged in the process and provided comments and ideas on every aspect of bicycling in the county.

For WalkHoward, public engagement consisted of three open houses, online and printed surveys, and various opportunities that allowed the public to identify challenges and opportunities related to the accessibility and comfort of walking.

Transportation projects can also be identified outside of the formal planning process by members of the public or County staff, especially if there is a documented safety issue.

There are two ways a transportation project can advance out of the planning phase. A project can be funded by the County as a Capital Project or funded by a private developer as part of a Private Development Project. The Transportation Improvement Prioritization System (TIPS) document describes the process that County staff follows to evaluate and prioritize project ideas for funding through the County Capital Budget. Projects funded by a private developer occur when a parcel is proposed for redevelopment and is not based on the merit of the project.

Transportation projects must meet the requirements of the Subdivision and Land Development Regulations, the Howard County Design Manual, and the Complete Streets policy, which was adopted by resolution.

## COUNTY CAPITAL TRANSPORTATION PROJECTS

Once a project is prioritized for inclusion in the County's Capital Budget, it is included in the Capital Improvement Master Plan or C.I.M.P for Transportation. Section 18.212 of the county code defines the C.I.M.P. for Transportation as:

"...a plan proposed by the County Executive upon the recommendations of the Director of Public Works and the Director of Planning and Zoning and adopted by the County Council pursuant to the provisions of section 22.405 of the Howard County Code. The plan indicates the capital improvements to the County's road and bridge network and public transportation system to be constructed during the next ten years in order to implement the housing and employment growth projections of the County's general plan. The C.I.M.P. for Transportation includes the roads, bridges, traffic lights, and public transportation system projects included in the Howard County Capital Budget and Capital Program and Extended Capital Program and the Maryland Consolidated Transportation Program."

The Capital Budget includes many types of transportation projects including bridge, road construction or reconstruction, road resurfacing, sidewalk/curb projects, and traffic/intersection projects. More complex projects generally cost more money and require more public engagement to develop a solution that works for community stakeholders. Less complex projects generally cost less money and require less public engagement to develop an appropriate design solution. For the purposes of the Community Engagement Plan, we are referring to these projects as "Major" and "Minor."

Simple (Minor Projects)	Complex (Major Projects)
Decision already made	Decision still needs to be made
Implementation stage, when government can implement on its own	Design and development stage
Routine	Potentially controversial
Based on accepted, known values	Based on values in conflict
Technical analysis provides clear answer	Technical analysis does not provide clear answer
Stakeholders: small number, defined/known, homogenous	Stakeholders: large number, undefined/unknown, diverse



Figure 10: Complexity of decision matrix for designating a project major or minor for purposes of public engagement, adapted from Hurley-Franks Associates, 2009



All potential Major and Minor Capital Projects are reviewed as a group during the “Potential Improvement Identification” and “Funding” steps, those checklists are included as Appendix B of this document. Letters are used as an abbreviation to describe the project type in the County Capital Budget as indicated in parentheses after the project type.

**Major Capital Transportation Projects include:**

- All bridge construction or reconstruction projects (B),
- All road construction or reconstruction projects (J),
- Sidewalk/curb projects (K), and;
- Some traffic/intersection projects (T).

Staff checklists for each phase of the Major Capital project process are included as Appendix C of this document.

**Minor Capital Transportation Projects include:**

- Some major road resurfacing (H),
- Some sidewalk/curb projects (K), and;
- Some traffic/intersection projects (T).

Whether an H, K, or T project is considered a Major or Minor project is determined by Howard County staff based on the complexity of the project. Once a project is determined to be Major or Minor by County staff, it follows the project development and engagement process outlined on the next two pages.

Staff checklists for each phase of the Minor Capital project process are included as Appendix D of this document.

The checklists provided in Appendix B-D are for public reference only. OOT and DPW maintain dynamic versions of the checklists that they use for project management purposes.

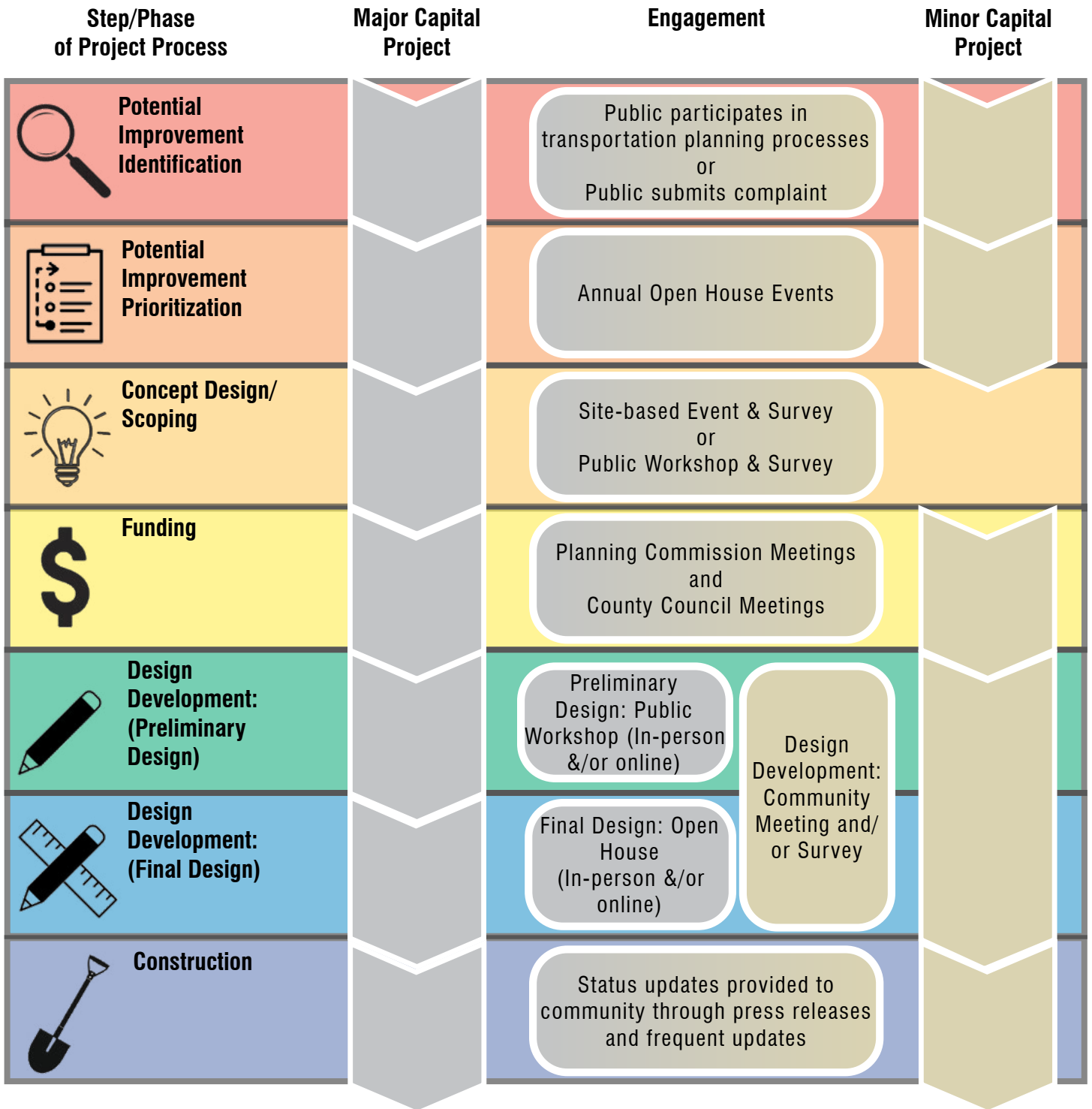

Figure 11: Overview of public engagement process for major and minor capital projects



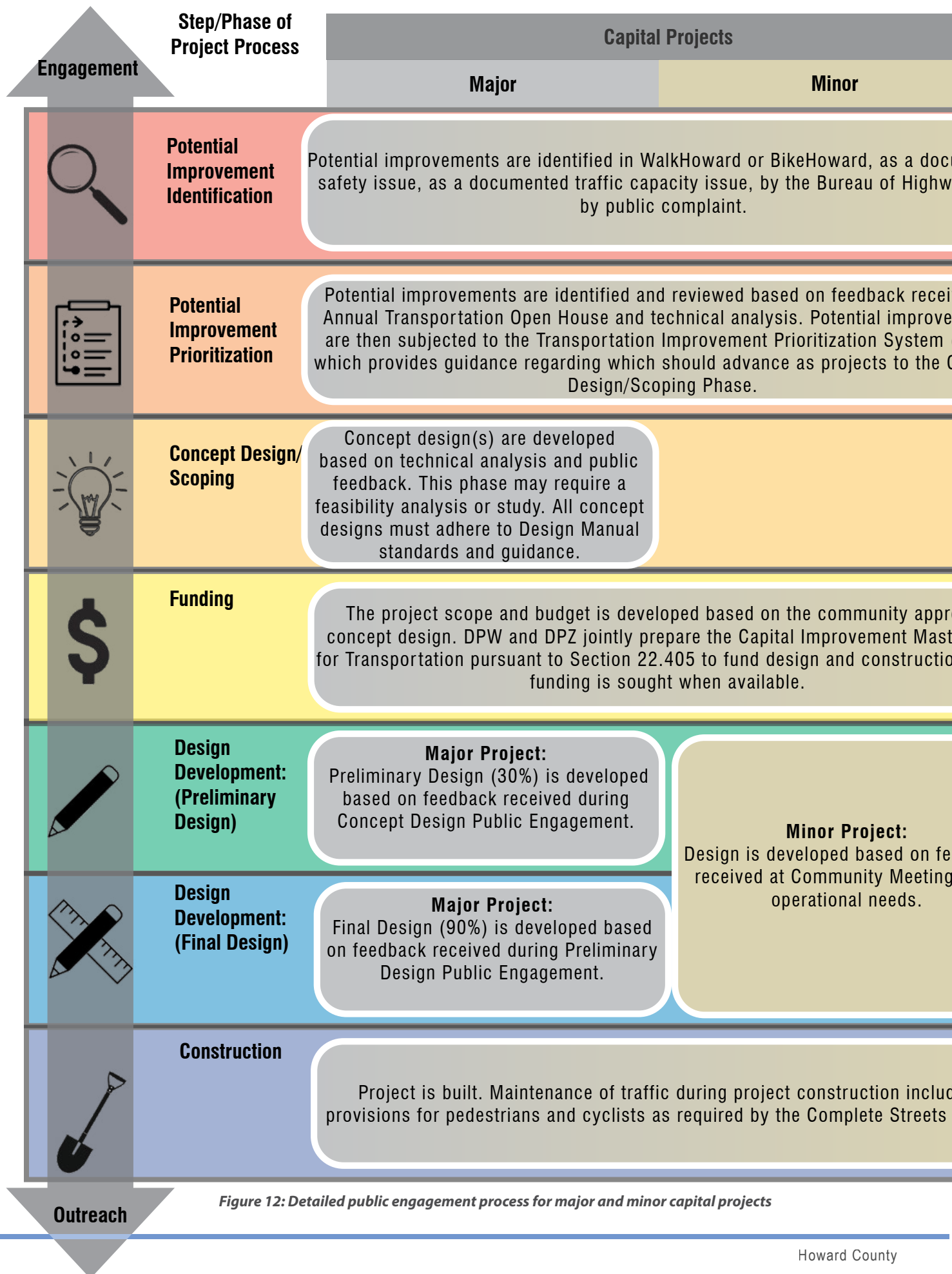

Figure 12: Detailed public engagement process for major and minor capital projects

Public Engagement Process		Lead Agency
Major	Minor	
Documented ways, or	The public can identify potential improvements by participating in the transportation planning process, or by submitting a complaint to the Howard County Department of Public Works about an issue in their neighborhood.	
Involved at meetings (TIPS) Concept	The purpose of the <b>Annual Open House</b> is to provide the general public with information about the Complete Streets program in Howard County and create an opportunity for the public to provide feedback on which transportation improvements should be prioritized by the County for funding.	Office of Transportation
	The purpose of scheduling a <b>Workshop</b> or <b>Site-Based Event</b> for a high-priority Major Capital Project is to ensure that community priorities are understood in order to develop the scope and budget.	Office of Transportation
Approved Inter Plan n. Grant	The purpose of this phase is to provide members of the Complete Streets email list and other interested stakeholders with the information they need to meaningfully participate in the Transportation Capital Project budget process.	Office of Transportation
Feedbacks and	<p><b>Major Project:</b> The purpose of the Preliminary Design Public Workshop is to present capital project concept designs to the public in-person and/or online for review and to collect feedback that may be incorporated into the final design of the project.</p> <p><b>Minor Project:</b> The purpose of the Community Meeting is to present capital project concept designs to the public in-person and/or online for review and to collect feedback that may be incorporated into the final design of the project.</p>	Department of Public Works
	<p><b>Major Project:</b> The purpose of the Final Design Open House is to present capital project final designs to the public in-person and/or online for public review.</p>	Department of Public Works
Policy.	Regular updates build trust between community stakeholders and the County, especially if there is a significant delay between Final Design completion and construction.	Department of Public Works

## PRIVATE DEVELOPMENT PROJECTS

The Division of Land Development within the Department of Planning and Zoning administers the development plan review process in an efficient and consistent manner to ensure that proposed development plans conform to all County regulations and are functional. Additionally, the Division helps property owners, business owners, community associations, realtors, prospective homeowners, and others obtain the information they need on development regulations and or plan approvals.

### Development Technical Review

The Development Engineering Division (DED) is tasked with ensuring that commercial and residential development projects meet current State and County design requirements, including requirements relating to the transportation network. In addition, development projects must meet the requirements of the Complete Streets policy, which was adopted by resolution and states, "The County shall require developers to implement the Complete Streets policy as per this policy." DED is tasked with making sure that new subdivision roads and frontage improvements to existing roads are constructed with any new development. Improvements are governed by the requirements as set forth in the Howard County Design Manual, Volume III, Roads and Bridges, and the Howard County Design Manual, Volume IV, Standard Specifications and Details for Construction and the Howard County Design Manual - Volume IV, May 1, 2014 Revisions Only.

DED is tasked with evaluating whether developments impact existing road intersections by increasing traffic flow to unacceptable levels as prescribed in the current Howard County Code and Howard County Design Manual, Volume III. DED evaluates whether mitigation is required through construction of road improvements, intersection modifications, or whether a fee-in-lieu is to be paid into a Capital Project to correct the deficient intersection.

## Major Subdivisions and Commercial Site Development Plans

Major Subdivisions and Commercial Site Development Plans are large projects that provide significant opportunity to make critical connections within the bicycle and pedestrian network; community engagement is an important part of this process.

A Major Subdivision is when a private development project proposes splitting an existing parcel into five or more parcels, usually for construction. The County reviews approximately 89 residential subdivisions and 22 commercial subdivisions a year according to the April 2020 Development Monitoring System Report.

A Commercial Site Development Plan is a detailed engineered drawing of a commercial development project on a single parcel, showing existing site conditions and proposed improvements with sufficient detail for agency review, approval, and subsequent construction. The Major Subdivision process also requires the completion of a Site Development Plan for the resulting parcels. The County reviews approximately 21 Commercial Site Development plans each year according to the April 2020 Development Monitoring System Report.

Major Subdivisions and Commercial Site Development Plans follow the project development and engagement process outlined on the next page. The process does not apply to Minor Subdivisions or Non-Commercial Site Development Plan submissions.

Staff checklists for the for the Multimodal Transportation Board and Planning Board meetings are included as Appendix E of this document.

The checklists provided in Appendix E are for public reference only. OOT and DPZ maintain dynamic versions of the checklists that they use for project management purposes.

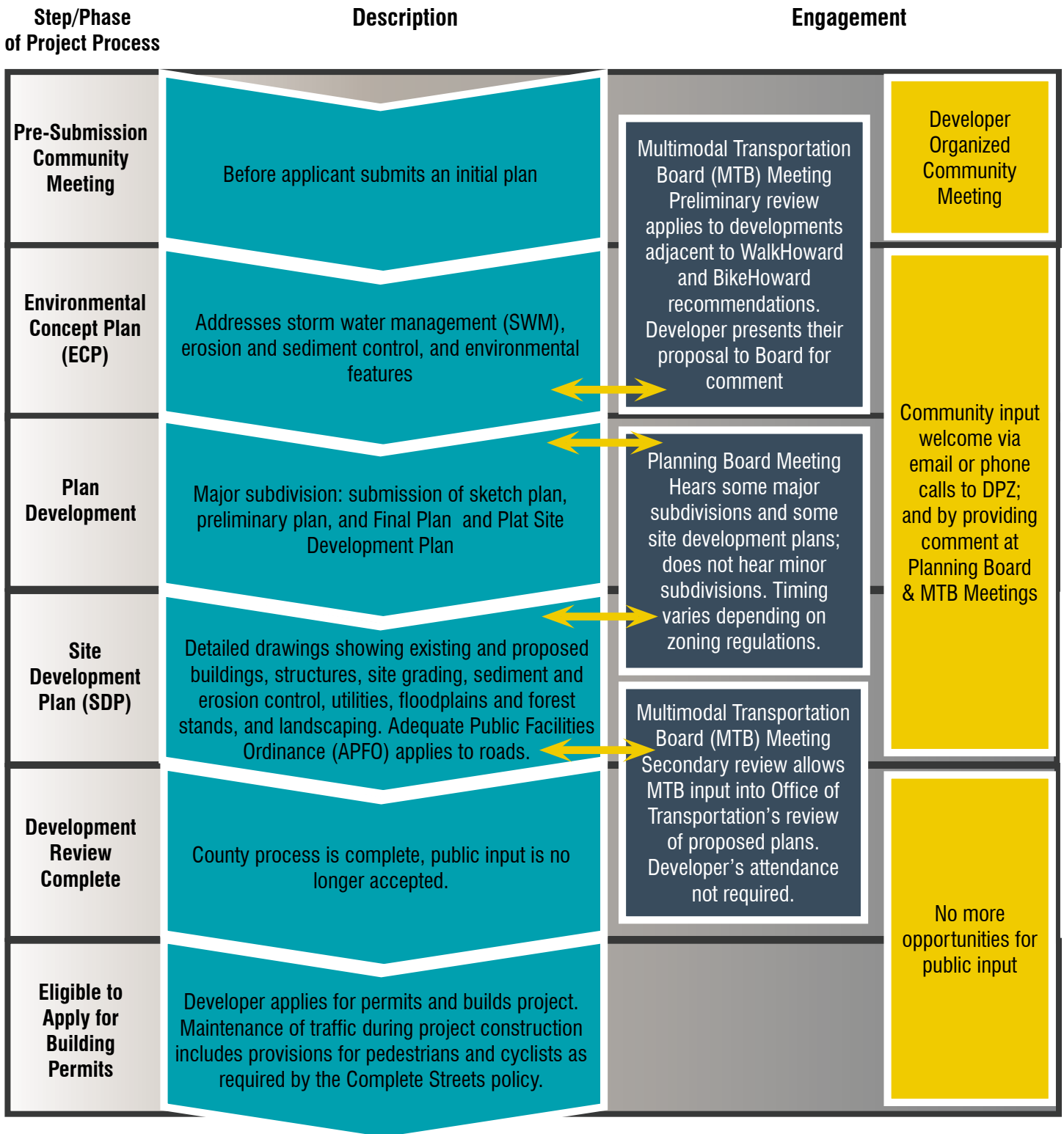

Figure 13: Public engagement process for private development projects

# Citizen's Guide to Community Engagement

This Community Engagement Plan provides guidance to County staff on how to collaborate and collect feedback from the public on transportation projects in Howard County.

You are an expert on your community because you use the streets around your home every time you leave the house. You have insights that transportation professionals don't have, since you observe how your streets work at all times of the day throughout the year. Your insights will help the County design transportation facilities that work for you and your neighbors.

Any text below that is blue and underlined is a live link - just click it to travel to the linked website or document.

## Frequently Asked Questions

[I would like to know more about transportation projects across Howard County. How can I get involved?](#)

*Visit the Howard County Complete Streets Website:*

- Bookmark the Howard County Complete Streets website:

[www.howardcountymd.gov/completestreets](http://www.howardcountymd.gov/completestreets)

*Sign up for Complete Streets Email Updates:*

- Sign up for the Howard County Office of Transportation Complete Streets listserv by visiting:

[www.howardcountymd.gov/completestreets](http://www.howardcountymd.gov/completestreets)

- Text to join is an option that should be explored for a future version of this plan.

*Follow us on Social Media:*

- Follow Howard County Office of Transportation's social media pages:

[www.facebook.com/CommuteHoward](http://www.facebook.com/CommuteHoward)

[www.twitter.com/commutehoward](http://www.twitter.com/commutehoward)

*Attend Public Meetings:*

Upcoming meetings will be advertised on the Complete Streets website, via email, and via social media. There are multiple regularly occurring meetings that are open to the public where transportation projects are discussed.

Attend the BikeHoward and Complete Streets Open House, generally held every January. At the Open House, you will have the chance to talk to County Staff about current projects and offer feedback on which proposed improvements are important to you.

The [Multimodal Transportation Board](#) (MTB) holds meetings monthly and they are open to the public. Meetings are generally on the fourth Tuesday of the month at 7:00 p.m. in the George Howard Building, 3430 Court House Drive, Ellicott City, Maryland 21043, or virtually as appropriate. The MTB advises the County Executive and County Administration on transportation matters. Agendas, minutes, and meeting materials are available on the County website.

The [Bicycle Advisory Group](#) (BAG) advises the County Executive and County Administration on matters of bicycle transportation, particularly the implementation of the Bicycle Master Plan. The BAG meets at least quarterly, and two of its meetings are required by the Howard County Code to be joint meetings with the Transit and Pedestrian Advisory Group (see below). Agendas, minutes, and meeting materials are available on the County website.

[I would like to know more about transportation projects happening in my neighborhood. What can I do to make sure I am notified? Is there a way to check the status of a particular project?](#)

The Complete Streets website includes a form to sign up to receive notices about upcoming public meetings and events related to County transportation projects.

[If I miss a public meeting, can I still provide input?](#)

- We understand not everyone can attend a meeting at a specific time, and not everyone may be comfortable providing feedback in a public forum
- Materials from every meeting will be posted to the project website for review along with an online survey so you can provide feedback
- All feedback received from the public will be



taken into consideration, whether provided at a public meeting or via an online survey, email, or phone call

### Why doesn't the design of the project reflect my comments?

- Although public feedback impacts the project design, designers and engineers are required to follow the Howard County Design Manual and the Howard County Subdivision and Land Development regulations when designing a project. Sometimes public recommendations conflict with the guidance offered in those documents. Howard County staff and representatives will do their best to address public comments while still following the technical requirements. In instances where design guidance conflicts with a public comment, the County will do their best to explain why in a way that the public can understand.
- The greatest opportunity to impact the design of a project is during the beginning planning phase of a project before a lot of money, time, and resources are spent on developing a detailed plan. At the beginning of a project, designers have questions that that members of the public can answer to inform the design of the project. As questions are answered based on public feedback and technical analysis, the design progresses, and becomes more difficult to change. By the final design phase, the purpose of public engagement is to inform the public about what the design will be and explain how public feedback was incorporated throughout the process.

### How long does it take for a transportation project to move from a proposed transportation improvement to construction?

Capital transportation projects vary greatly in their size, scope, and complexity. There is no average amount of time it takes for a project to move from a proposed improvement to construction. The County will provide the public with an estimated timeline for the planning and design of every capital project and will notify the public if that schedule changes significantly. Oftentimes, the most unpredictable and time consuming part of a transportation project is between design and construction, when issues of project funding, land ownership, utilities, and easements are being resolved. After those issues are worked out and funding is secured, the project can go to construction. The Department of Public Works provides the public with estimated timelines for the construction of capital projects and will notify the public if that schedule changes significantly.

It is even more difficult to provide an estimate on how much time a developer led project will take, since timing is dictated by the private developer's schedule. The Department of Planning and Zoning will answer questions about the timing of a developer led project on a case-by-case basis.

## Some Howard County Transportation Terms You Should Know

### *Complete Streets*

According to the National Complete Streets Coalition, “Complete Streets are streets for everyone. They are designed and operated to enable safe access for all users, including pedestrians, bicyclists, motorists and transit riders of all ages and abilities. Complete Streets make it easy to cross the street, walk to shops, and bicycle to work.”

### *Howard County Complete Streets Policy*

The Howard County Council unanimously adopted the Complete Streets Resolution [CR120-2019](#) on October 7, 2019. The vision of Howard County’s Complete Streets policy is “To ensure that Howard County is a place for individuals of all backgrounds to live and travel freely, safely, and comfortably, public and private roadways in Howard County shall be safe and convenient for residents of all ages and abilities who travel by foot, bicycle, public transportation or automobile, ensuring sustainable communities Countywide.”

### *Howard County Complete Streets Implementation Team (CSIT)*

The [CSIT](#) is the group tasked by the County Executive with implementing Howard County’s Complete Streets policy. The CSIT has 14 members, seven of which are Howard County government representatives, and seven of which are external stakeholders. The CSIT is responsible for ensuring that the following things happen:

- Draft, adopt, and implement this Community Engagement Plan
- Draft, adopt, and implement the Transportation Improvement Prioritization System
- Update the Howard County Design Manual
- Produce a publicly available Annual Report that provides updates on all projects and the status of all Complete Streets performance measures

### *Howard County Design Manual*

The [Howard County Design Manual](#) is the document that shows Howard County engineers and designers how public infrastructure should be designed and built. [Volume III of the Design Manual](#) focuses on roads and bridges, and includes criteria and standards for the design of safe, efficient, and coordinated road systems. It also includes criteria for planning, environmental, bicyclist, and pedestrian related issues. Both private developer led projects and County led capital projects must conform to the Design Manual.

The Complete Streets policy requires that the Design Manual be updated to more fully incorporate Complete Streets by October 2021.

### *Subdivision and Land Development Regulations*

The Howard County Subdivision and Land Development regulations are intended to promote the health, safety, and general welfare of the residents of the County by assisting orderly, efficient, and integrated development of land and providing uniform procedures and standards for the processing of development plans. All private development in Howard County must confirm to the Subdivision and Land Development Regulations before it can be constructed.

### *Howard County Transportation Master Plans*

Howard County transportation master plans provide guidance on where and how the County should invest in the transportation network, including walking and bicycling.

### *PlanHoward and HoCo By Design*

PlanHoward is the current general plan for Howard County. It is a long-range, visionary document that guides land use decisions, including decisions about where to make investments in the transportation network. HoCo By Design is Howard County’s next general plan update, which is underway in 2020 and 2021.

A General Plan is required by Howard County Code. It includes demographic and population projections and assesses capacity to accommodate changes and growth. It evaluates demands on roads, schools, utilities, parks, housing, and other infrastructure and develops strategies to meet projected deficiencies. It anticipates how growth impacts community facilities and the environment and identifies areas where growth occurs. The State of Maryland provides a framework that suggests the following elements be included or addressed in General Plan policies: quality of life and sustainability, public participation, growth areas, community design, infrastructure, transportation, housing, economic development, environmental protection, resource conservation, stewardship, and implementation.

For more information, visit the [HoCo By Design](#) website.

# WHAT DOES THE GENERAL PLAN INFLUENCE?

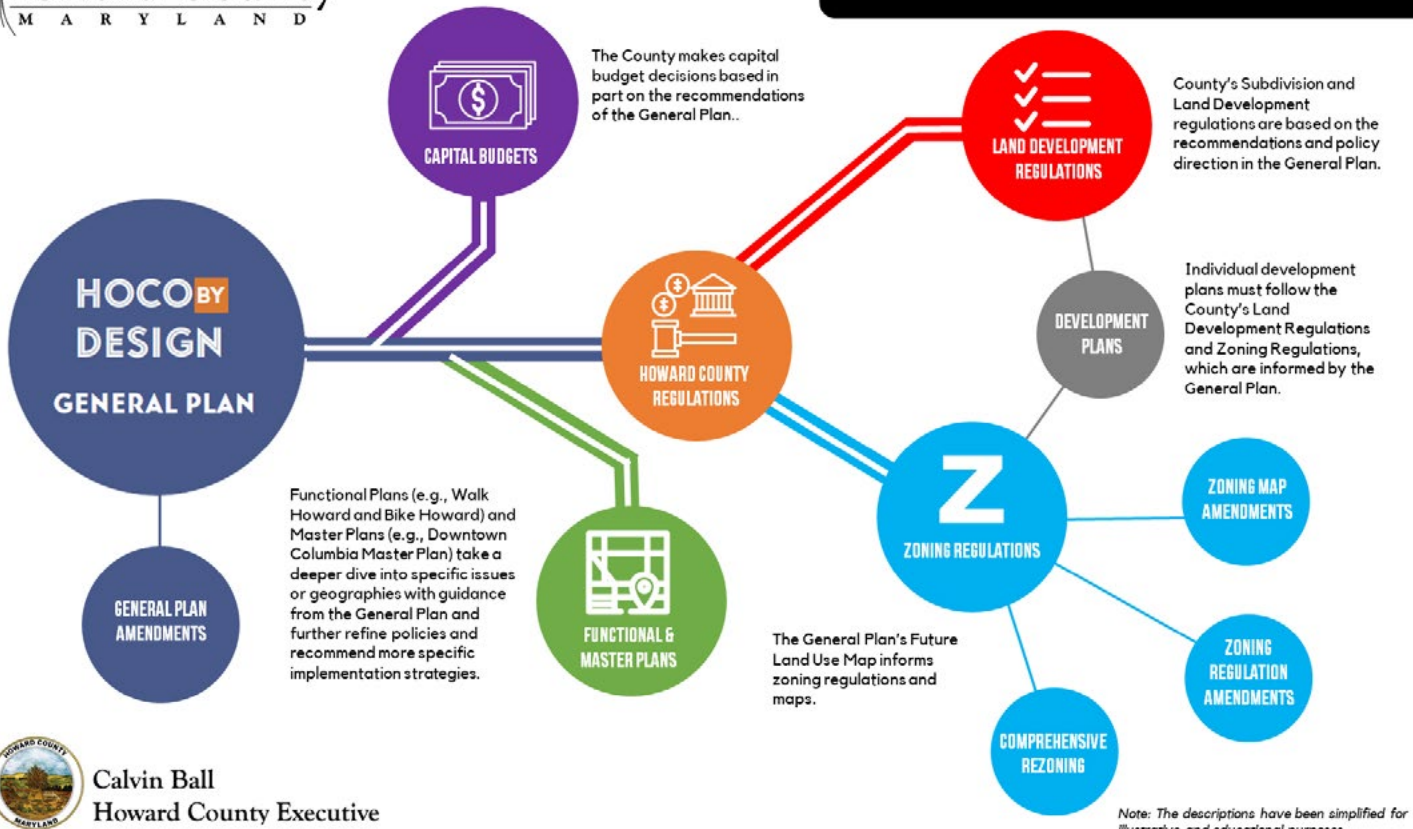

### BikeHoward

BikeHoward, the Howard County bicycle master plan, was adopted by the County Council in 2016. The plan provides guidance for improvements for transportation and recreational bicycling, both on-street and off-street. Recommendations are provided in the general areas of infrastructure improvements, policy and programs.

For more information, visit the [BikeHoward website](#).

### WalkHoward

WalkHoward is Howard County's pedestrian master plan and was adopted in February 2020 through Council Resolution 14-2020. This master plan addresses walking in all of its forms – whether you are trying to get somewhere or just taking a casual stroll somewhere you love.

For more information, visit the [WalkHoward website](#).

## **Infrastructure Types**

### *Bike Lane*

Pavement marking designating a portion of roadway for preferential use of bicycles.

### *Buffered Bike Lane*

A type of bike lane with additional striped buffer zones to provide increased separation from faster moving traffic.

### *Climbing Lane*

Used where existing road width will support addition of only one bike lane. Bike lane provided in uphill and shared lane marking on the downhill portion of the road.

### *Separated Bike Lane (Cycletrack)*

A one or two-way bicycle facility that is physically separated from moving traffic and pedestrians to create a lower stress bicycling experience.

### *Shared Roadway*

Generally used on rural roads and neighborhood streets where there is good sight distance and low traffic volumes. Shared lane markings (sometimes known as “sharrows”) are used where the speed limit is 35 mph or lower. Although shared roadways don’t count as bicycle facilities, in selected locations they may fill gaps in the bicycle network, indicating cyclists’ safest path of travel and reminding motorists of their obligation to share the road.

### *Shared Use Pathway*

An off-street bicycle and pedestrian facility, physically separated from the road and motor vehicle traffic creates a lower stress experience for people walking and bicycling.

### *Sidewalk*

An off-street facility for people to walk. In general, sidewalk bicycling is discouraged, except for children and those just learning to ride a bicycle. In Howard County many casual and recreational cyclists ride on sidewalks for short sections of their ride or even long distances, because conditions on the roadway are too uncomfortable. Sidewalk cycling is permitted by county code.

### *Crosswalk*

A recommended location for pedestrians to cross a road where drivers are required by law to stop for crossing pedestrians. Crosswalks may be marked or unmarked. Crosswalks that are not at intersections are always marked.

### *Pedestrian Refuge Island*

A small section of pavement or sidewalk in the middle of a roadway with a refuge area intended to help protect pedestrians who are crossing a multi-lane road.

### *High-Intensity Activated Crosswalk (HAWK) Signal*

A pedestrian activated traffic control device used to stop road traffic to allow pedestrians to cross safely.

### *Rapid Rectangular Flashing Beacon (RRFB)*

A pedestrian activated traffic control device used to increase driver yielding behavior at crosswalks to allow pedestrians to cross safely.

# Appendices

**Appendix A: Stakeholder List**

**Appendix B: Project Prioritization and Funding Checklists**

**Appendix C: Major Capital Project Checklists**

**Appendix D: Minor Capital Project Checklists**

**Appendix E: Private Development Project Checklists**



# Stakeholder List

Appendix A

Complete Streets - Community Organizations	Service Area	Website
90+ Cycling	Countywide	<a href="https://www.90pluscycling.com/">https://www.90pluscycling.com/</a>
AARP MD	Statewide	<a href="https://states.aarp.org/maryland/">https://states.aarp.org/maryland/</a>
Accessible Resources for Independence	Countywide	<a href="https://arinow.org/">https://arinow.org/</a>
African American Coalition of Howard County, The	Countywide	<a href="https://www.afamcoalition.org/">https://www.afamcoalition.org/</a>
African American Community Roundtable	Countywide	<a href="https://www.aacr-howard.org/">https://www.aacr-howard.org/</a>
Agricultural Preservation Board	Countywide	<a href="https://www.howardcountymd.gov/boards-commissions/agricultural-preservation-board">https://www.howardcountymd.gov/boards-commissions/agricultural-preservation-board</a>
American Heart Association	Regional	<a href="https://www.heart.org/en/affiliates/maryland/gr eater-baltimore">https://www.heart.org/en/affiliates/maryland/gr eater-baltimore</a>
APL Cycling Club	Local	<a href="https://www.aplcycling.club/">https://www.aplcycling.club/</a>
Arc of Howard County, The	Countywide	<a href="https://www.archoward.org/">https://www.archoward.org/</a>
Association of Community Services	Countywide	<a href="http://www.acshoco.org/">www.acshoco.org/</a>
Baltimore Metropolitan Council	Regional	<a href="https://www.baltometro.org/">https://www.baltometro.org/</a>
Bicycle Advisory Group	Countywide	<a href="https://www.howardcountymd.gov/boards-commissions/bicycle-advisory-group">https://www.howardcountymd.gov/boards-commissions/bicycle-advisory-group</a>
Bicycling Advocates of Howard County (Bike HoCo)	Countywide	<a href="https://bikehoco.org/">https://bikehoco.org/</a>
Bike Maryland	statewide	<a href="https://www.bikemaryland.org/">https://www.bikemaryland.org/</a>
Black Student Achievement Program (HCPSS BASP)	Countywide	<a href="https://www.hcpss.org/schools/bsap/">https://www.hcpss.org/schools/bsap/</a>
Board to Promote Self-Sufficiency	Countywide	<a href="https://www.howardcountymd.gov/BPSS">https://www.howardcountymd.gov/BPSS</a>
Bridges to Housing Stability	Countywide	<a href="http://www.bridges2hs.org/contact-us/">www.bridges2hs.org/contact-us/</a>
Bright Minds	Countywide	<a href="https://brightmindsfoundation.org/">https://brightmindsfoundation.org/</a>
Business Women's Network of Howard County	Countywide	<a href="https://www.bwn-hoco.org/">https://www.bwn-hoco.org/</a>
Central Maryland Transportation Alliance	Regional	<a href="https://www.cmtalliance.org/">https://www.cmtalliance.org/</a>
Chin Association of Maryland (CAM)	Regional	<a href="https://chinmd.org/">https://chinmd.org/</a>
Chinese Parent Association of Howard County	Countywide	<a href="http://www.capa-hc.org/">www.capa-hc.org/</a>
Clean Water Action	Countywide	<a href="https://www.cleanwateraction.org/tags/howard-county">https://www.cleanwateraction.org/tags/howard-county</a>
Columbia Association	Local	<a href="http://www.columbiaassociation.org/">www.columbiaassociation.org/</a>
Columbia Community Care	Countywide	<a href="http://www.columbiacare.live/">www.columbiacare.live/</a>
Columbia Patuxent Rotary Club	Local	<a href="https://columbiarotary.com/">https://columbiarotary.com/</a>
Columbia Rotary Club	Local	<a href="http://www.columbiarotary.org/">www.columbiarotary.org/</a>
Columbia Town Center Rotary Club	Local	<a href="http://www.ctcrotary.org/">www.ctcrotary.org/</a>
Commission for Veterans and Military Families	Countywide	<a href="https://www.howardcountymd.gov/VetComm">https://www.howardcountymd.gov/VetComm</a>
Commission on Aging	Countywide	<a href="https://www.howardcountymd.gov/COA">https://www.howardcountymd.gov/COA</a>
Commission on Disabilities	Countywide	<a href="https://www.howardcountymd.gov/CoD">https://www.howardcountymd.gov/CoD</a>
Commission on Transitioning Students with Disabilities	Countywide	<a href="https://www.howardcountymd.gov/HCCTSD">https://www.howardcountymd.gov/HCCTSD</a>
Community Action Council	Countywide	<a href="http://www.cac-hc.org/">www.cac-hc.org/</a>
Community Ecology Institute	Countywide	<a href="https://www.communityecologyinstitute.org/">https://www.communityecologyinstitute.org/</a>
Community Foundation of Howard County	Countywide	<a href="https://cfhoco.org/">https://cfhoco.org/</a>
Conexiones of Howard County	Countywide	<a href="http://www.conexioneshc.org/">www.conexioneshc.org/</a>

Council of Elders, The	Countywide	<a href="https://www.thecouncilofelders.org/">https://www.thecouncilofelders.org/</a>
Cycle Mill Bike Shop, The	Countywide	<a href="https://www.cyclemillofmd.com/">https://www.cyclemillofmd.com/</a>
Cycle2Health	Countywide	<a href="https://www.howardcountymd.gov/C2H">https://www.howardcountymd.gov/C2H</a>
Design Advisory Panel	Countywide	<a href="https://www.howardcountymd.gov/boards-commissions/design-advisory-panel">https://www.howardcountymd.gov/boards-commissions/design-advisory-panel</a>
Downtown Columbia Partnership	Local	<a href="http://www.dtcpartnership.com/">www.dtcpartnership.com/</a>
Elkridge Rotary Club	Local	<a href="https://elkridgerotaryclub.org/">https://elkridgerotaryclub.org/</a>
Ellicott City Partnership	Local	<a href="https://visitoldellicottcity.com/item/ellicott-city-partnership/">https://visitoldellicottcity.com/item/ellicott-city-partnership/</a>
Equity4HC	Countywide	<a href="https://equity4hc.com/">https://equity4hc.com/</a>
FIRN (Foreign-Born Information and Referral Network)	Countywide	<a href="http://www.firnonline.org">www.firnonline.org</a>
Free Bikes 4 Kidz	Countywide	<a href="https://fb4kmaryland.org/">https://fb4kmaryland.org/</a>
Village in Howard	Local	<a href="https://www.thevillageinhoward.org/">https://www.thevillageinhoward.org/</a>
Girls on the Run Central Maryland	Countywide	<a href="http://www.gotrcentralmd.org">www.gotrcentralmd.org</a>
Grassroots Crisis and Intervention Center	Countywide	<a href="https://www.grassrootscrisis.org/">https://www.grassrootscrisis.org/</a>
Hispanic Achievement Liaisons (HCPSS)	Countywide	<a href="https://www.hcpss.org/schools/academic-intervention/#:~:text=The%20Hispanic%20Achievement%20Liaisons%20are,achievement%20of%20all%20Hispanic%20students.">https://www.hcpss.org/schools/academic-intervention/#:~:text=The%20Hispanic%20Achievement%20Liaisons%20are,achievement%20of%20all%20Hispanic%20students.</a>
Historic Preservation Commission	Countywide	<a href="https://www.howardcountymd.gov/boards-commissions/historic-preservation-commission">https://www.howardcountymd.gov/boards-commissions/historic-preservation-commission</a>
HoCoCyclists	countywide	<a href="https://hococyclists.com/">https://hococyclists.com/</a>
HopeWorks of Howard County	Countywide	<a href="https://hopeworksofhc.org/">https://hopeworksofhc.org/</a>
Horizon Foundation	Countywide	<a href="http://www.thehorizonfoundation.org/">www.thehorizonfoundation.org/</a>
Housing and Community Development Board	Countywide	<a href="https://www.howardcountymd.gov/DHCD-Board">https://www.howardcountymd.gov/DHCD-Board</a>
Howard Community College	Countywide	<a href="http://www.howardcc.edu/">www.howardcc.edu/</a>
Howard County Age Friendly	Countywide	<a href="https://www.howardcountymd.gov/agefriendly">https://www.howardcountymd.gov/agefriendly</a>
Howard County Association of Realtors	Countywide	<a href="https://hcar.org/">https://hcar.org/</a>
Howard County Association of Student Councils	Countywide	<a href="https://sites.google.com/a/inst.hcpss.me/hcasc/">https://sites.google.com/a/inst.hcpss.me/hcasc/</a>
Howard County Autism Society	Countywide	<a href="https://howard-autism.org/">https://howard-autism.org/</a>
Howard County Chamber of Commerce	Countywide	<a href="http://www.howardchamber.com/">www.howardchamber.com/</a>
Howard County Chinese School	Countywide	<a href="http://hccs-md.org/information">http://hccs-md.org/information</a>
Howard County Citizens Association	Countywide	<a href="http://howardcountyhcca.org/">http://howardcountyhcca.org/</a>
Howard County Clergy Alliance	Countywide	<a href="https://pathiaf.files.wordpress.com/2020/06/hoco-clergy-alliance-june-2020-5.pdf">https://pathiaf.files.wordpress.com/2020/06/hoco-clergy-alliance-june-2020-5.pdf</a>
Howard County Coalition for Immigrant Justice	countywide	<a href="https://indivisiblehocomd.org/action-teams/immigration/howard-county-coalition-for-immigrant-justice/">https://indivisiblehocomd.org/action-teams/immigration/howard-county-coalition-for-immigrant-justice/</a>
Howard County Conservancy	Countywide	<a href="https://www.howardnature.org/">https://www.howardnature.org/</a>
Howard County Department of Community Resources and Services	Countywide	<a href="https://www.howardcountymd.gov/DCRS">https://www.howardcountymd.gov/DCRS</a>

Howard County Department of Housing and Community Development	Countywide	<a href="https://www.howardcountymd.gov/housing-community-development">https://www.howardcountymd.gov/housing-community-development</a>
Howard County Department of Planning and Zoning	Countywide	<a href="https://www.howardcountymd.gov/planning-zoning/zoning">https://www.howardcountymd.gov/planning-zoning/zoning</a>
Howard County Department of Public Works	Countywide	<a href="https://www.howardcountymd.gov/public-works">https://www.howardcountymd.gov/public-works</a>
Howard County Department of Recreation and Parks	Countywide	<a href="https://www.howardcountymd.gov/rap">https://www.howardcountymd.gov/rap</a>
Howard County Department of Social Services	Countywide	<a href="https://dhs.maryland.gov/Local-offices/howard-county/">https://dhs.maryland.gov/Local-offices/howard-county/</a>
Howard County Economic Development Authority	Countywide	<a href="http://www.hceda.org/">http://www.hceda.org/</a>
Howard County EcoWorks	Countywide	<a href="https://www.howardecoworks.org/">https://www.howardecoworks.org/</a>
Howard County Friends of Latin Americans	Countywide	<a href="https://friendsoflatinamerica.org/">https://friendsoflatinamerica.org/</a>
Howard County Housing Commission - House Howard	Countywide	<a href="http://www.househoward.org">www.househoward.org</a>
Howard County Library Services	Countywide	<a href="http://hclibrary.org/">http://hclibrary.org/</a>
Howard County Local Health Improvement Coalition (LHIC)	Countywide	<a href="http://www.hclhic.org/">http://www.hclhic.org/</a>
Howard County MD Lynching Truth & Reconciliation	Local	<a href="http://www.hocoltr.org/">http://www.hocoltr.org/</a>
Howard County Office of ADA Coordination	Countywide	<a href="https://www.howardcountymd.gov/ADA">https://www.howardcountymd.gov/ADA</a>
Howard County Office of Aging and Independence	Countywide	<a href="https://www.howardcountymd.gov/aging">https://www.howardcountymd.gov/aging</a>
Howard County Office of Transportation	Countywide	<a href="http://www.howardcountymd.gov/Transportation">www.howardcountymd.gov/Transportation</a>
Howard County Office of Workforce Development	Countywide	<a href="http://www.howardcountymd.gov/Workforce-Development">www.howardcountymd.gov/Workforce-Development</a>
Howard County Police Department	countywide	<a href="https://www.howardcountymd.gov/Departments/Police/">https://www.howardcountymd.gov/Departments/Police/</a>
Howard County PRIDE	Countywide	<a href="https://www.howardcountypride.org/">https://www.howardcountypride.org/</a>
Howard County Public School System (HCPSS)	Countywide	<a href="http://www.hcpss.org/">www.hcpss.org/</a>
Howard County Public Works Board	Countywide	<a href="https://www.howardcountymd.gov/boards-commissions/public-works-board">https://www.howardcountymd.gov/boards-commissions/public-works-board</a>
Howard County Racial Equity Task Force	Countywide	<a href="https://cc.howardcountymd.gov/About-Us/Commissions-Task-Forces-and-Special-Reports/Racial-Equity-Task-Force">https://cc.howardcountymd.gov/About-Us/Commissions-Task-Forces-and-Special-Reports/Racial-Equity-Task-Force</a>
Howard County Sierra Club	Countywide	<a href="https://www.sierraclub.org/maryland/howard-county-group">https://www.sierraclub.org/maryland/howard-county-group</a>
Howard County State Delegation	Countywide	<a href="https://www.howardcountymd.gov/leadership/state-delegation">https://www.howardcountymd.gov/leadership/state-delegation</a>
Howard County Striders	Countywide	<a href="http://www.striders.net">www.striders.net</a>
Howard West Rotary Club	Local	<a href="http://www.howardwestrotary.com/">www.howardwestrotary.com/</a>
Human Rights Commission	Countywide	<a href="https://www.howardcountymd.gov/OHRE">https://www.howardcountymd.gov/OHRE</a>
Indian Cultural Association of Howard County	Countywide	<a href="http://www.indianculturalassociation.org">www.indianculturalassociation.org</a>
Indian Origin Network of Howard County (IONHoCo)	Countywide	<a href="http://www.ionhoco.org">www.ionhoco.org</a>
Just Living Advocacy	Countywide	<a href="https://www.justlivingadvocacy.org/">https://www.justlivingadvocacy.org/</a>

Korean American Association of Howard County	Countywide	<a href="http://www.kacahi.us">www.kacahi.us</a>
La Alianza Latina Worksgroup	Countywide	<a href="mailto:alianzalatina@howardcountymd.gov">alianzalatina@howardcountymd.gov</a>
Leadership Howard County	Countywide	<a href="https://www.leadershiphc.org/">https://www.leadershiphc.org/</a>
League of Korean Americans (LoKA) of Howard County	Countywide	<a href="https://www.lokamd.org/">https://www.lokamd.org/</a>
Local Children's Board	Countywide	<a href="https://www.howardcountymd.gov/LCB">https://www.howardcountymd.gov/LCB</a>
Maryland Transit Administration	Statewide	<a href="http://www.mta.maryland.gov/">www.mta.maryland.gov/</a>
MDOT public meeting webpage	Statewide	<a href="https://www.mdot.maryland.gov/tso/pages/Ind ex.aspx?PagelD=142">https://www.mdot.maryland.gov/tso/pages/Ind ex.aspx?PagelD=142</a>
Merriweather District	Local	<a href="https://merriweatherdistrict.com/">https://merriweatherdistrict.com/</a>
Merriweather Post, The	Local	<a href="https://www.themerriweatherpost.org/">https://www.themerriweatherpost.org/</a>
Multimodal Transportation Board	Countywide	<a href="https://www.howardcountymd.gov/boards-commissions/multimodal-transportation-board">https://www.howardcountymd.gov/boards-commissions/multimodal-transportation-board</a>
NAACP	Countywide	<a href="http://www.howardcountynaacp.com">www.howardcountynaacp.com</a>
NAMI Howard County	Countywide	<a href="http://www.namihowardcounty.org">www.namihowardcounty.org</a>
National Association of Industrial and Office Parks (NAIOP), MD chapter	Regional	<a href="http://www.naiopmd.org">www.naiopmd.org</a>
Nava Be Diné	Regional	<a href="https://navabedine.com/">https://navabedine.com/</a>
Neighbor Ride	Countywide	<a href="http://www.neighborride.org/">www.neighborride.org/</a>
Patapsco Bicycles	Countywide	<a href="https://www.patapscobike.com/">https://www.patapscobike.com/</a>
Patapsco Heritage Greenway	Regional	<a href="https://patapsco.org/">https://patapsco.org/</a>
People Acting Together in Howard (PATH)	Countywide	<a href="https://pathiaf.com/">https://pathiaf.com/</a>
People's Voice, The	Countywide	<a href="https://www.peoplesvoicellc.org/">https://www.peoplesvoicellc.org/</a>
PFLAG Columbia/Howard County Chapter	Countywide	<a href="https://www.pflaghoco.org/">https://www.pflaghoco.org/</a>
Planning Advisory Committee for HoCo By Design	Countywide	<a href="https://www.hocobydesign.com/planning-advisory-committee">https://www.hocobydesign.com/planning-advisory-committee</a>
Planning Board	Countywide	<a href="https://www.howardcountymd.gov/boards-commissions/planning-board">https://www.howardcountymd.gov/boards-commissions/planning-board</a>
Power 52 Foundation	Local	<a href="https://www.power52.org/">https://www.power52.org/</a>
PTA Council of Howard County (PTACHC)	Countywide	<a href="https://www.ptachc.org/">https://www.ptachc.org/</a>
Race Pace Bicycles	Regional	<a href="https://www.racepacebicycles.com/about/columbia-pg609.htm">https://www.racepacebicycles.com/about/columbia-pg609.htm</a>
Recreation and Parks Advisory Board	Countywide	<a href="https://www.howardcountymd.gov/boards-commissions/recreation-parks-advisory-board">https://www.howardcountymd.gov/boards-commissions/recreation-parks-advisory-board</a>
Regional Transportation Agency of Central Maryland (RTA)	Regional	<a href="http://www.transitrt.com/">www.transitrt.com/</a>
REI Bike Shop	Countywide	<a href="https://www.rei.com/stores/columbia/bike-shop">https://www.rei.com/stores/columbia/bike-shop</a>
Robinson Nature Center	Local	<a href="https://www.howardcountymd.gov/recreation-parks/RobinsonNatureCenter">https://www.howardcountymd.gov/recreation-parks/RobinsonNatureCenter</a>
Streets for All	Countywide	<a href="https://hcstreetsforall.org/contact-us/">https://hcstreetsforall.org/contact-us/</a>
United Way of Central Maryland	Regional	<a href="https://www.uwcm.org/">https://www.uwcm.org/</a>
Velo City Riders	Statewide	<a href="https://www.velocityriders.org/">https://www.velocityriders.org/</a>



Voices for Change	Countywide	<a href="https://community-programs.hcpss.org/2021-01/voices-change#:~:text=Voices%20for%20Change%20is%20a,a%20forum%20for%20open%20discussion.">https://community-programs.hcpss.org/2021-01/voices-change#:~:text=Voices%20for%20Change%20is%20a,a%20forum%20for%20open%20discussion.</a>
Why Not Jessup?	Local	<a href="http://jessuphs.tacobird.com/">http://jessuphs.tacobird.com/</a>
Women's Giving Circle of Howard County	Countywide	<a href="https://www.womensgivingcircle.org/">https://www.womensgivingcircle.org/</a>
Y in Central Maryland, The	Regional	<a href="https://ymaryland.org/locations/dancely">https://ymaryland.org/locations/dancely</a>

# Project Prioritization and Funding Checklists

Appendix B

Potential Improvement Prioritization Annual Open House - Engagement Checklist		Date
Check when complete	<b>Plan for Open House (starting about 3 months before Event)</b>	#####
	<ul style="list-style-type: none"> <li>• Set date in consideration of holiday schedules and current County calendar; Enter proposed event date in highlighted box (remaining dates will auto populate)</li> </ul>	
	<ul style="list-style-type: none"> <li>• Determine location (in-person) and/or select software and platform (online); create SNAP request for meeting, if needed</li> </ul>	
	<ul style="list-style-type: none"> <li>• Develop goals, outcomes, and specific engagement strategies for the outreach and event</li> </ul>	
	<ul style="list-style-type: none"> <li>• Determine budget for event</li> </ul>	
	<ul style="list-style-type: none"> <li>• Develop communications plan with the Office of Public Information</li> </ul>	
<b>Develop &amp; Distribute Marketing (starting 2 Months before Open House)</b>		#####
	<ul style="list-style-type: none"> <li>• Develop Open House scope and schedule with key internal staff for the project and project outreach</li> </ul>	
	<ul style="list-style-type: none"> <li>• Prepare Open House notifications, including press release, flyer, Constant Contact, social media messaging, emails, letters, etc. Add registration link (if virtual) or meeting details (in person). Provide opportunity to sign up for Constant Contact notifications.</li> </ul>	
<b>Advertise Event (starting about 4 weeks before Event)</b>		#####
	<ul style="list-style-type: none"> <li>• Post flyer and messaging on all County social media pages, relevant websites, and County calendar</li> </ul>	
	<ul style="list-style-type: none"> <li>• Send to relevant listservs on Constant Contact (i.e., General, Complete Streets, BikeHoward, WalkHoward)</li> </ul>	
	<ul style="list-style-type: none"> <li>• Email community organizations, County agencies and County departments and ask them to promote with their contacts; include flyer</li> </ul>	
	<ul style="list-style-type: none"> <li>• Request County Council members by email to notify constituents (via OoT Administrator or other); include flyer</li> </ul>	
	<ul style="list-style-type: none"> <li>• Post at the meeting site, and nearby, as appropriate</li> </ul>	
	<ul style="list-style-type: none"> <li>• Provide information to PIO for inclusion in County Executive news bulletin</li> </ul>	
	<ul style="list-style-type: none"> <li>• Promote social media event, send reminders in advance of event; secure targeted social media advertisements with ad boosting in project area if project budget permits</li> </ul>	
	<ul style="list-style-type: none"> <li>• Submit to online calendars for local media for 2 weeks prior to meeting</li> </ul>	#####
	<ul style="list-style-type: none"> <li>• Place flyer on public access cable channels and monitors in County Buildings through PIO week before meeting</li> </ul>	
	<ul style="list-style-type: none"> <li>• Develop meeting materials, graphics, and activities (prepared with WCAG standards where possible)</li> </ul>	
	<ul style="list-style-type: none"> <li>• Develop mechanisms for feedback (i.e., SurveyMonkey, interactive boards, etc.) and meeting evaluation (e.g., surveys)</li> </ul>	
	<ul style="list-style-type: none"> <li>• Secure interpreters, as needed (i.e., ASL, foreign language)</li> </ul>	
	<ul style="list-style-type: none"> <li>• Address logistics for on-site meeting; meet with DTCS to address virtual meeting requirements, as needed</li> </ul>	
<b>Hold Open House</b>		
	<ul style="list-style-type: none"> <li>• Request all attendees to sign in (automatic for virtual event)</li> </ul>	
	<ul style="list-style-type: none"> <li>• Arrange for sufficient staff to be available for in-person event; host virtual event(s), as needed</li> </ul>	
	<ul style="list-style-type: none"> <li>• Ensure the meeting is accessible, materials are of high quality, and public is treated with courtesy</li> </ul>	
	<ul style="list-style-type: none"> <li>• Collect feedback using feedback mechanism</li> </ul>	
	<ul style="list-style-type: none"> <li>• Request participants complete a meeting evaluation; encourage attendees to sign up for project listservs</li> </ul>	
<b>Event Follow-up (starting 1 day after Event)</b>		#####
	<ul style="list-style-type: none"> <li>• Summarize analytics for outreach; summarize analytics for attendance (e.g. attendees, attendance across time)</li> </ul>	

	<ul style="list-style-type: none"><li>• Document the Open House, including content, number of attendees, Q&amp;A, outreach, engagement, evaluation, etc. on project website for at least one month; link to the Complete Streets website; provide report to others, if needed</li></ul>
	<ul style="list-style-type: none"><li>• Link Open House website to Complete Streets website for 2 weeks to 1 month, as appropriate</li></ul>
	<ul style="list-style-type: none"><li>• Communicate with attendees and community organizations via email and Constant Contact - and post on social media event walls - to:</li></ul>
	<ul style="list-style-type: none"><li><ul style="list-style-type: none"><li>• Thank attendees and provide link to Open House materials and evaluation</li><li>• Include list proposed transportation projects; encourage sharing with networks</li></ul></li></ul>
	<ul style="list-style-type: none"><li>• Follow up on any outstanding questions, comments received from attendees</li></ul>
	<ul style="list-style-type: none"><li>• Remove flyers posted on-site after comment period is over</li></ul>
	<ul style="list-style-type: none"><li>• Post this completed checklist on project website</li></ul>

<b>Capital Project Funding - Engagement Checklist</b>		<b>Date</b>
<b>County Executive's 1st Residents Budget Hearing (December)</b>		
	• Enter meeting date in highlighted box (remaining dates will auto populate)	
	• Send reminder to Complete Streets email list and social media followers 2 weeks before meeting	#####
	• Send reminder to Complete Streets email list and social media followers 1 week before meeting	#####
	• Send reminder to Complete Streets email list and social media followers 1 day before meeting	#####
<b>Planning Board Meeting (February)</b>		
The Planning Board typically meets the first and third Thursday of each month beginning at 7:00 pm in the Banneker Room of the George Howard Building (3430 Court House Drive, Ellicott City, MD 21043). Alternative dates may be scheduled at the discretion of the Board. Meeting agendas and all supplemental materials are posted to the Planning Board website two (2) weeks in advance of the meeting date.		
	• Enter meeting date in highlighted box (remaining dates will auto populate)	
	• Notify Complete Streets email list, social media followers, and post on Complete Streets website when Planning Board meeting materials and agenda are posted to the Planning Board website for public review	#####
	• Send reminder to Complete Streets email list and social media followers 1 week before meeting	#####
	• Send reminder to Complete Streets email list and social media followers 1 day before meeting	#####
	• After meeting, distribute Planning Board ranking of new projects and recommendations for County Executive to Complete Streets email list, via social media, and post on Complete Streets website	#####
<b>County Executive's 2nd Residents Budget Hearing (March)</b>		
	• Enter meeting date in highlighted box (remaining dates will auto populate)	
	• Send reminder to Complete Streets email list and social media followers 2 weeks before meeting	#####
	• Send reminder to Complete Streets email list and social media followers 1 week before meeting	#####
	• Send reminder to Complete Streets email list and social media followers 1 day before meeting	#####
<b>County Council Public Hearings (April/May)</b>		
	• Enter meeting date in highlighted box (remaining dates will auto populate)	
	• Send reminder to Complete Streets email list and social media followers 2 weeks before meeting	#####
	• Send reminder to Complete Streets email list and social media followers 1 week before meeting	#####
	• Send reminder to Complete Streets email list and social media followers 1 day before meeting	#####
<b>County Council Approves Capital Budget (June)</b>		
	• Distribute notice of approval and copy of budget to Complete Streets email list, via social media, and post on Complete Streets website	#####
	• Include description of approved projects and link to project website if possible	



# Major Capital Project Checklists

Appendix C

Major Capital Project Concept Design - Engagement Checklist		Date
Check when complete	<b>Plan for Event (starting about 6 weeks before Event)</b>	#####
	<ul style="list-style-type: none"> <li>• Set date in consideration of holiday schedules and current County calendar; Enter proposed event date in highlighted box (remaining dates will auto populate)</li> </ul>	
	<ul style="list-style-type: none"> <li>• Determine location (in-person) and/or select software and platform (online) for virtual meeting; create SNAP request for meeting, if needed</li> </ul>	
	<ul style="list-style-type: none"> <li>• Develop preliminary Community Stakeholder list based on project location and Equity Emphasis Area values (e.g., HOAs, Constant Contact listservs, community organizations, County Council members)</li> </ul>	
	<ul style="list-style-type: none"> <li>• Develop goals, outcomes, and specific engagement strategies for the outreach and event</li> </ul>	
	<ul style="list-style-type: none"> <li>• Determine budget for event, as needed</li> </ul>	
	<ul style="list-style-type: none"> <li>• Set up a project website. Add registration link (if virtual) or meeting details (in person). Provide opportunity to sign up for project notifications. Add relevant project history, information, images, etc.</li> </ul>	
	<ul style="list-style-type: none"> <li>• Review project scope and schedule with key staff for the project and project outreach</li> </ul>	
	<ul style="list-style-type: none"> <li>• Prepare project notifications, including flyer, social media messaging, emails, letters, etc.</li> </ul>	
	<b>Advertise Event (starting about 4 weeks before Event)</b>	#####
	<ul style="list-style-type: none"> <li>• Post flyer and messaging on all County social media pages, relevant websites, and County calendar</li> </ul>	
	<ul style="list-style-type: none"> <li>• Send to relevant listservs on Constant Contact (i.e., project listserv, General, Complete Streets, BikeHoward, WalkHoward)</li> </ul>	
	<ul style="list-style-type: none"> <li>• Email Community Stakeholders, County agencies and County departments and ask them to promote with their contacts; include flyer</li> </ul>	
	<ul style="list-style-type: none"> <li>• Request County Council members by email to notify constituents (via OoT Administrator or other); include flyer</li> </ul>	
	<ul style="list-style-type: none"> <li>• Identify and provide notice to property owners, key businesses, schools, community centers, etc. adjacent to or within 1/4 or 1/2 mile from project site by mail; contact DPZ list of registered subscribers via email, if possible</li> </ul>	
	<ul style="list-style-type: none"> <li>• Post flyer onsite, at the meeting site, and at nearby businesses, community centers, and bus stops, as appropriate</li> </ul>	
	<ul style="list-style-type: none"> <li>• Provide information to PIO for inclusion in County Executive news bulletin</li> </ul>	
	<ul style="list-style-type: none"> <li>• Promote social media event, send reminders in advance of event; secure targeted social media advertisements with ad boosting in project area if project budget permits</li> </ul>	
	<ul style="list-style-type: none"> <li>• Submit to online calendars for local media for 2 weeks prior to meeting</li> </ul>	
	<b>Prepare for Event (starting about 3 weeks before Event)</b>	#####
	<ul style="list-style-type: none"> <li>• Develop meeting materials, graphics, and activities (prepared with WCAG standards where possible)</li> </ul>	
	<ul style="list-style-type: none"> <li>• Develop mechanisms for feedback (i.e., SurveyMonkey, interactive boards, etc.) and meeting evaluation (e.g., surveys)</li> </ul>	
	<ul style="list-style-type: none"> <li>• Secure interpreters, as needed (i.e., ASL, foreign language)</li> </ul>	
	<ul style="list-style-type: none"> <li>• Address logistics for on-site meeting; meet with DTCS to address virtual meeting requirements, as needed</li> </ul>	
	<ul style="list-style-type: none"> <li>• Notify, as needed, Community Stakeholder list and emphasize importance of feedback and sharing with networks 1 week before meeting</li> </ul>	
	<ul style="list-style-type: none"> <li>• Place flyer on public access cable channels and monitors in County Buildings through PIO 1 week before meeting (not needed for site-specific projects)</li> </ul>	
	<b>Hold Event</b>	
	<ul style="list-style-type: none"> <li>• Request all attendees to sign in; allow attendees to sign up for project listservs</li> </ul>	

	<ul style="list-style-type: none"> <li>• Arrange for sufficient staff to be available for in-person event; host virtual event(s), as needed</li> </ul>	
	<ul style="list-style-type: none"> <li>• Ensure the meeting is accessible, materials are of high quality, and public is treated with courtesy; record if virtual; take notes if in person event</li> </ul>	
	<ul style="list-style-type: none"> <li>• Collect feedback using feedback mechanism</li> </ul>	
	<ul style="list-style-type: none"> <li>• Request participants complete a meeting evaluation</li> </ul>	
<b>Event Follow-up (starting 1 day after Event)</b>		#####
	<ul style="list-style-type: none"> <li>• Summarize analytics for outreach; summarize analytics for attendance (e.g. attendees, attendance across time)</li> </ul>	
	<ul style="list-style-type: none"> <li>• Document the event, including content, number of attendees, Q&amp;A, survey results, outreach, evaluation, etc. on project website for at least one month; link to the Complete Streets website; provide report to others, if needed</li> </ul>	
	<ul style="list-style-type: none"> <li>• Post materials and provide opportunity for feedback on Complete Streets website for 2 weeks to 1 month, as appropriate</li> </ul>	
	<ul style="list-style-type: none"> <li>• Communicate with attendees and Community Stakeholders - and post on social media event walls - to: <ul style="list-style-type: none"> <li>• Thank attendees and provide link to meeting evaluation</li> <li>• Provide link to meeting materials and feedback mechanism (if any)</li> <li>• Share project schedule/next steps; encourage sharing with networks</li> </ul> </li> </ul>	
	<ul style="list-style-type: none"> <li>• Follow up on any outstanding questions, comments</li> </ul>	
	<ul style="list-style-type: none"> <li>• Remove flyers posted on-site after comment period is over</li> </ul>	
	<ul style="list-style-type: none"> <li>• Post this completed checklist on project website (noting which tasks were completed)</li> </ul>	

Major Capital Project Preliminary Design - Engagement Checklist		Date
Check when complete	<b>Plan for Outreach (starting about 6 weeks before Event)</b>	#####
	<ul style="list-style-type: none"> <li>• Set date in consideration of holiday schedules and current County calendar; Enter proposed event date in highlighted box (remaining dates will auto populate)</li> </ul>	
	<ul style="list-style-type: none"> <li>• Determine location (in-person) and/or select software and platform (online) for virtual meeting; create SNAP request for meeting, if needed</li> </ul>	
	<ul style="list-style-type: none"> <li>• Develop preliminary Community Stakeholder list based on project location and Equity Emphasis Area values (e.g., HOAs, Constant Contact listservs, community organizations, County Council members)</li> </ul>	
	<ul style="list-style-type: none"> <li>• Develop goals, outcomes, and specific engagement strategies for the outreach and event</li> </ul>	
	<ul style="list-style-type: none"> <li>• Determine budget for event, as needed</li> </ul>	
	<ul style="list-style-type: none"> <li>• Set up a project website. Add registration link (if virtual) or meeting details (in person). Provide opportunity to sign up for project notifications. Add relevant project history, information, images, etc.</li> </ul>	
	<ul style="list-style-type: none"> <li>• Review project scope and schedule with key internal staff for the project and project outreach</li> </ul>	
	<ul style="list-style-type: none"> <li>• Prepare project notifications, including flyer, social media messaging, emails, letters, etc.</li> </ul>	
<b>Advertise Event (starting about 4 weeks before Event)</b>		#####
	<ul style="list-style-type: none"> <li>• Post flyer and messaging on all County social media pages, relevant websites, and County calendar</li> </ul>	
	<ul style="list-style-type: none"> <li>• Send to relevant listservs on Constant Contact (i.e., General, Complete Streets, BikeHoward, WalkHoward)</li> </ul>	
	<ul style="list-style-type: none"> <li>• Email Project Community Stakeholders, County agencies and County departments with flyer and messaging; and ask them to promote with their contacts</li> </ul>	
	<ul style="list-style-type: none"> <li>• Request County Council members by email to notify constituents (via OoT Administrator or other); include flyer</li> </ul>	
	<ul style="list-style-type: none"> <li>• Identify and provide notice to property owners, key businesses, schools, community centers, etc. adjacent to or within 1/4 or 1/2 mile from project site by mail; contact DPZ list of registered subscribers via email, if possible</li> </ul>	
	<ul style="list-style-type: none"> <li>• Post flyer onsite, at the meeting site, and at nearby businesses, community centers, and bus stops, as appropriate</li> </ul>	
	<ul style="list-style-type: none"> <li>• Provide information to PIO for inclusion in County Executive news bulletin</li> </ul>	
	<ul style="list-style-type: none"> <li>• Promote social media event, send reminders in advance of event; secure targeted social media advertisements with ad boosting in project area if project budget permits</li> </ul>	
	<ul style="list-style-type: none"> <li>• Submit to online calendars for local media for 2 weeks prior to meeting</li> </ul>	
<b>Prepare for Event (starting about 3 weeks before Event)</b>		#####
	<ul style="list-style-type: none"> <li>• Develop meeting materials, graphics, and activities (prepared with WCAG standards where possible)</li> </ul>	
	<ul style="list-style-type: none"> <li>• Develop mechanisms for feedback (i.e., SurveyMonkey, interactive boards, etc.) and meeting evaluation (e.g., surveys)</li> </ul>	
	<ul style="list-style-type: none"> <li>• Secure interpreters, as needed (i.e., ASL, foreign language)</li> </ul>	
	<ul style="list-style-type: none"> <li>• Address logistics for on-site meeting; meet with DTCS to address virtual meeting requirements, as needed</li> </ul>	
	<ul style="list-style-type: none"> <li>• Notify, as needed, Community Stakeholder list and emphasize importance of feedback and sharing with networks 1 week before meeting</li> </ul>	
	<ul style="list-style-type: none"> <li>• Place flyer on public access cable channels and monitors in County Buildings through PIO 1 week before meeting (not needed for site-specific projects)</li> </ul>	
<b>Hold Event</b>		
	<ul style="list-style-type: none"> <li>• Request all attendees to sign in; allow attendees to sign up for project listservs</li> </ul>	
	<ul style="list-style-type: none"> <li>• Arrange for sufficient staff to be available for in-person event; host virtual event(s), as needed</li> </ul>	

	<ul style="list-style-type: none"> <li>• Ensure the meeting is accessible, materials are of high quality, and public is treated with courtesy; record if virtual; take notes if in person event</li> </ul>	
	<ul style="list-style-type: none"> <li>• Collect feedback using feedback mechanism</li> </ul>	
	<ul style="list-style-type: none"> <li>• Request participants complete a meeting evaluation</li> </ul>	
<b>Event Follow-up (starting 1 day after Event)</b>		#####
	<ul style="list-style-type: none"> <li>• Summarize analytics for outreach; summarize analytics for attendance (e.g. attendees, attendance across time)</li> </ul>	
	<ul style="list-style-type: none"> <li>• Document the event, including content, number of attendees, Q&amp;A, survey results, outreach, evaluation, etc. on project website for at least one month; link to the Complete Streets website; provide report to others, if needed</li> </ul>	
	<ul style="list-style-type: none"> <li>• Post materials and provide opportunity for feedback on Complete Streets website for 2 weeks to 1 month</li> </ul>	
	<ul style="list-style-type: none"> <li>• Communicate with attendees and Community Stakeholders - and post on social media event walls - to: <ul style="list-style-type: none"> <li>• Thank attendees and provide link to meeting evaluation</li> <li>• Provide link to meeting materials and feedback mechanism (if any)</li> <li>• Share project schedule/next steps; encourage sharing with networks</li> </ul> </li> </ul>	
	<ul style="list-style-type: none"> <li>• Follow up on any outstanding questions, comments</li> </ul>	
	<ul style="list-style-type: none"> <li>• Remove flyers posted on-site after comment period is over</li> </ul>	
	<ul style="list-style-type: none"> <li>• Post this completed checklist on project website (noting which tasks were completed)</li> </ul>	



Major Capital Project Final Design - Engagement Checklist		Date
Check when complete	<b>Plan for Event (starting about 6 weeks before Event)</b>	#####
	<ul style="list-style-type: none"> <li>• Set date in consideration of holiday schedules and current County calendar; Enter proposed event date in highlighted box (remaining dates will auto populate)</li> </ul>	
	<ul style="list-style-type: none"> <li>• Determine location (in-person) and/or select software and platform (online) for virtual meeting; create SNAP request for meeting, if needed</li> </ul>	
	<ul style="list-style-type: none"> <li>• Develop preliminary Community Stakeholder list based on project location and Equity Emphasis Area values (e.g., HOAs, Constant Contact listservs, community organizations, County Council members)</li> </ul>	
	<ul style="list-style-type: none"> <li>• Develop goals, outcomes, and specific engagement strategies for the outreach and event</li> </ul>	
	<ul style="list-style-type: none"> <li>• Determine budget for event, as needed</li> </ul>	
	<ul style="list-style-type: none"> <li>• Set up a project website. Add registration link (if virtual) or meeting details (in person). Provide opportunity to sign up for project notifications. Add relevant project history, information, images, etc.</li> </ul>	
	<ul style="list-style-type: none"> <li>• Review project scope and schedule with key internal staff for the project and project outreach</li> </ul>	
	<ul style="list-style-type: none"> <li>• Prepare project notifications, including flyer, social media messaging, emails, letters, etc.</li> </ul>	
<b>Advertise Event (starting about 4 weeks before Event)</b>		#####
	<ul style="list-style-type: none"> <li>• Post flyer and messaging on all County social media pages, relevant websites, and County calendar</li> </ul>	
	<ul style="list-style-type: none"> <li>• Send to relevant listservs on Constant Contact (i.e., project listserv, General, Complete Streets, BikeHoward, WalkHoward)</li> </ul>	
	<ul style="list-style-type: none"> <li>• Email Community Stakeholders, County agencies and County departments and ask them to promote with their contacts; include flyer</li> </ul>	
	<ul style="list-style-type: none"> <li>• Request County Council members by email to notify constituents (via OoT Administrator or other); include flyer</li> </ul>	
	<ul style="list-style-type: none"> <li>• Identify and provide notice to property owners, key businesses, schools, community centers, etc. adjacent to or within 1/4 or 1/2 mile from project site by mail; contact DPZ list of registered subscribers via email, if possible</li> </ul>	
	<ul style="list-style-type: none"> <li>• Post flyer onsite, at the meeting site, and at nearby businesses, community centers, and bus stops, as appropriate</li> </ul>	
	<ul style="list-style-type: none"> <li>• Provide information to PIO for inclusion in County Executive news bulletin</li> </ul>	
	<ul style="list-style-type: none"> <li>• Promote social media event, send reminders in advance of event; secure targeted social media advertisements with ad boosting in project area if project budget permits</li> </ul>	
	<ul style="list-style-type: none"> <li>• Submit to online calendars for local media for 2 weeks prior to meeting</li> </ul>	
<b>Prepare for Event (starting about 3 weeks before Event)</b>		#####
	<ul style="list-style-type: none"> <li>• Develop meeting materials, graphics, and activities (prepared with WCAG standards where possible)</li> </ul>	
	<ul style="list-style-type: none"> <li>• Develop mechanisms for feedback (i.e., SurveyMonkey, interactive boards, etc.) and meeting evaluation (e.g., surveys)</li> </ul>	
	<ul style="list-style-type: none"> <li>• Secure interpreters, as needed (i.e., ASL, foreign language)</li> </ul>	
	<ul style="list-style-type: none"> <li>• Address logistics for on-site meeting; meet with DTCS to address virtual meeting requirements, as needed</li> </ul>	
	<ul style="list-style-type: none"> <li>• Notify, as needed, Community Stakeholder list and emphasize importance of feedback and sharing with networks 1 week before meeting</li> </ul>	
	<ul style="list-style-type: none"> <li>• Place flyer on public access cable channels and monitors in County Buildings through PIO 1 week before meeting (not needed for site-specific projects)</li> </ul>	
<b>Hold Event</b>		
	<ul style="list-style-type: none"> <li>• Request all attendees to sign in; allow attendees to sign up for project listservs</li> </ul>	
	<ul style="list-style-type: none"> <li>• Arrange for sufficient staff to be available for in-person event; host virtual event(s), as needed</li> </ul>	

	<ul style="list-style-type: none"> <li>• Ensure the meeting is accessible, materials are of high quality, and public is treated with courtesy; record if virtual; take notes if in person event</li> </ul>	
	<ul style="list-style-type: none"> <li>• Collect feedback using feedback mechanism</li> </ul>	
	<ul style="list-style-type: none"> <li>• Request participants complete a meeting evaluation</li> </ul>	
<b>Event Follow-up (starting 1 day after Event)</b>		#####
	<ul style="list-style-type: none"> <li>• Summarize analytics for outreach; summarize analytics for attendance (e.g. attendees, attendance across time)</li> </ul>	
	<ul style="list-style-type: none"> <li>• Document the event, including content, number of attendees, Q&amp;A, survey results, outreach, evaluation, etc. on project website for at least one month; link to the Complete Streets website; provide report to others, if needed</li> </ul>	
	<ul style="list-style-type: none"> <li>• Post materials and provide opportunity for feedback on Complete Streets website for 2 weeks to 1 month</li> </ul>	
	<ul style="list-style-type: none"> <li>• Communicate with attendees and Community Stakeholders - and post on social media event walls - to: <ul style="list-style-type: none"> <li>• Thank attendees and provide link to meeting evaluation</li> <li>• Provide link to meeting materials and feedback mechanism (if any)</li> <li>• Share project schedule/next steps; encourage sharing with networks</li> </ul> </li> </ul>	
	<ul style="list-style-type: none"> <li>• Follow up on any outstanding questions, comments</li> </ul>	
	<ul style="list-style-type: none"> <li>• Remove flyers posted on-site after comment period is over</li> </ul>	
	<ul style="list-style-type: none"> <li>• Post this completed checklist on project website (noting which tasks were completed)</li> </ul>	

Major Capital Project Construction - Engagement Checklist		Date
Check when complete	<p style="text-align: center;"><b>After Design is Finalized</b> (only necessary if there is significant time between completion of Final Design and start of construction)</p> <ul style="list-style-type: none"> <li>• Contact community stakeholders via Constant Contact, email, social media, and project website               <ul style="list-style-type: none"> <li>• Thank them for their time and feedback</li> <li>• Share final design</li> <li>• Share tentative construction schedule</li> <li>• Commit to notifying community if project is delayed</li> </ul> </li> </ul>	
<b>Before Construction (starting about 4 weeks before construction start)</b>		
	<ul style="list-style-type: none"> <li>• Work with Office of Public Information to prepare press release one month before construction starts               <ul style="list-style-type: none"> <li>• Describe construction schedule, impacts, and share project contact</li> <li>• Explain detours that will be in place for vehicles, bicycles, and pedestrians</li> </ul> </li> <li>• Distribute key information from press release via social media</li> <li>• Notify County Council, County agencies and departments to distribute information to constituents</li> <li>• Distribute key information to community stakeholders via Constant Contact, email, social media, and project website; commit to providing regular status updates</li> <li>• Post information onsite describing project, schedule, and community benefits</li> </ul>	
<b>During Construction</b>		
	<ul style="list-style-type: none"> <li>• Distribute updates to community stakeholders via email, social media, and project website               <ul style="list-style-type: none"> <li>• Include photographs of progress</li> <li>• Include project contact information</li> <li>• Include whether project is moving according to schedule</li> </ul> </li> </ul>	
<b>After Construction (starting after construction has begun)</b>		
	<ul style="list-style-type: none"> <li>• Work with Office of Public Information to plan ribbon cutting event (depending on size of project)</li> <li>• Invite community stakeholders to event via email, Constant Contact, project website, and social media</li> <li>• Send final thank you to community stakeholders via email, Constant Contact, mail, and social media               <ul style="list-style-type: none"> <li>• Include photographs of project before and after</li> <li>• Provide opportunity to sign up for Constant Contact</li> </ul> </li> </ul>	

# Minor Capital Project Checklists

Appendix D

Minor Capital Project Preliminary Design - Engagement Checklist		Date
Check when complete	<b>Plan for Outreach (starting about 6 weeks before Event)</b>	#####
	<ul style="list-style-type: none"> <li>Set date in consideration of holiday schedules and current County calendar; Enter proposed event date in highlighted box (remaining dates will auto populate); for minor projects, presenting at a regulary scheduled area community organization meeting(s) is preferred</li> </ul>	
	<ul style="list-style-type: none"> <li>Determine location (in-person) and/or select software and platform (online) for virtual meeting; create SNAP request for meeting, if needed</li> </ul>	
	<ul style="list-style-type: none"> <li>Develop preliminary Community Stakeholder list based on project location and Equity Emphasis Area values (e.g., HOAs, Constant Contact listservs, community organizations, County Council members)</li> </ul>	
	<ul style="list-style-type: none"> <li>Develop goals, outcomes, and specific engagement strategies for the outreach and event</li> </ul>	
	<ul style="list-style-type: none"> <li>Set up a project website. Add registration link (if virtual) or meeting details (in person). Provide opportunity to sign up for project notifications. Add relevant project history, information, images, etc.</li> </ul>	
	<ul style="list-style-type: none"> <li>Review project scope and schedule with key internal staff for the project and project outreach</li> </ul>	
	<ul style="list-style-type: none"> <li>Prepare project notifications, including flyer, social media messaging, emails, letters, etc.</li> </ul>	
	<b>Advertise Event (starting about 4 weeks before Event)</b>	#####
	<ul style="list-style-type: none"> <li>Post flyer and messaging on Office of Transportation social media pages and websites</li> </ul>	
	<ul style="list-style-type: none"> <li>Send to relevant listservs on Constant Contact (i.e., Project Community Stakeholders, BikeHoward or WalkHoward); ask Project Community Stakeholders to promote with their contacts</li> </ul>	
	<ul style="list-style-type: none"> <li>Request County Council members by email to notify constituents (via OoT Administrator or other); include flyer</li> </ul>	
	<ul style="list-style-type: none"> <li>Identify and provide notice to property owners, key businesses, schools, community centers, etc. adjacent to or within 1/4 or 1/2 mile from project site by mail; contact DPZ list of registered subscribers via email, if possible</li> </ul>	
	<ul style="list-style-type: none"> <li>Post flyer onsite, at the meeting site, and at nearby businesses, community centers, and bus stops, as appropriate</li> </ul>	
	<ul style="list-style-type: none"> <li>Provide information to PIO for inclusion in County Executive news bulletin</li> </ul>	
	<b>Prepare for Event (starting about 3 weeks before Event)</b>	#####
	<ul style="list-style-type: none"> <li>Develop meeting materials, graphics, and activities (prepared with WCAG standards where possible)</li> </ul>	
	<ul style="list-style-type: none"> <li>Develop mechanisms for feedback (i.e., SurveyMonkey, interactive boards, etc.) and meeting evaluation (e.g., surveys)</li> </ul>	
	<ul style="list-style-type: none"> <li>Address logistics for on-site meeting; meet with DTCS to address virtual meeting requirements, as needed</li> </ul>	
	<ul style="list-style-type: none"> <li>Notify, as needed, Community Stakeholder list and emphasize importance of feedback and sharing with networks 1 week before meeting</li> </ul>	
	<b>Hold Event</b>	
	<ul style="list-style-type: none"> <li>Request all attendees to sign in; allow attendees to sign up for listservs</li> </ul>	
	<ul style="list-style-type: none"> <li>Arrange for sufficient staff to be available for in-person event; host virtual event(s), as needed</li> </ul>	
	<ul style="list-style-type: none"> <li>Ensure the meeting is accessible, materials are of high quality, and public is treated with courtesy; record if virtual; take notes if in person event</li> </ul>	
	<ul style="list-style-type: none"> <li>Collect feedback using feedback mechanism</li> </ul>	
	<ul style="list-style-type: none"> <li>Request participants complete a meeting evaluation</li> </ul>	
	<b>Event Follow-up (starting 1 day after Event)</b>	1/28/1900
	<ul style="list-style-type: none"> <li>Document the event, including content, number of attendees, Q&amp;A, survey results, outreach, evaluation, etc. on project website for at least one month; link to the Complete Streets website; provide report to others, if needed</li> </ul>	

	• Post materials and provide opportunity for feedback on Complete Streets website for 2 weeks to 1 month
	• Communicate with attendees and Community Stakeholders - and post on social media event walls - to:
	<ul style="list-style-type: none"> <li>• Thank attendees and provide link to meeting evaluation</li> <li>• Provide link to meeting materials and feedback mechanism (if any)</li> <li>• Share project schedule/next steps; encourage sharing with networks</li> </ul>
	• Follow up on any outstanding questions, comments
	• Remove flyers posted on-site after comment period is over
	• Post this completed checklist on project website (noting which tasks were completed)



Minor Capital Project Construction - Engagement Checklist		Date
Check when complete	<p style="text-align: center;"><b>After Design is Finalized</b> (only necessary if there is significant time between completion of Final Design and start of construction)</p> <ul style="list-style-type: none"> <li>• Contact community stakeholders via Constant Contact, email, social media, and project website               <ul style="list-style-type: none"> <li>• Thank them for their time and feedback</li> <li>• Share final design</li> <li>• Share tentative construction schedule</li> <li>• Commit to notifying community if project is delayed</li> </ul> </li> </ul>	
<b>Before Construction (starting about 4 weeks before construction start)</b>		
	<ul style="list-style-type: none"> <li>• Work with Office of Public Information to prepare press release one month before construction starts               <ul style="list-style-type: none"> <li>• Describe construction schedule, impacts, and share project contact</li> <li>• Explain detours that will be in place for vehicles, bicycles, and pedestrians</li> </ul> </li> <li>• Distribute key information from press release via social media</li> <li>• Notify County Council, County agencies and departments to distribute information to constituents</li> <li>• Distribute key information to community stakeholders via Constant Contact, email, social media, and project website; commit to providing regular status updates</li> <li>• Post information onsite describing project, schedule, and community benefits</li> </ul>	
<b>During Construction</b>		
	<ul style="list-style-type: none"> <li>• Distribute updates to community stakeholders via email, social media, and project website               <ul style="list-style-type: none"> <li>• Include photographs of progress</li> <li>• Include project contact information</li> <li>• Include whether project is moving according to schedule</li> </ul> </li> </ul>	
<b>After Construction (starting after construction has begun)</b>		
	<ul style="list-style-type: none"> <li>• Work with Office of Public Information to plan ribbon cutting event (depending on size of project)</li> <li>• Invite community stakeholders to event via email, Constant Contact, project website, and social media</li> <li>• Send final thank you to community stakeholders via email, Constant Contact, mail, and social media               <ul style="list-style-type: none"> <li>• Include photographs of project before and after</li> <li>• Provide opportunity to sign up for Constant Contact</li> </ul> </li> </ul>	

# Private Development Project Checklists

Appendix E

Initial MTB Meeting Checklist		Date
Check when complete	<b>Multimodal Transportation Board Meeting Preparation (4 weeks before Meeting)</b>	#####
	• Enter meeting date in highlighted box (remaining dates will auto populate)	
	• Develop brief description of project, overview of existing adjacent multimodal facilities, and overview of planned multimodal facilities included in WalkHoward and BikeHoward	
	• Develop list of Community Stakeholders based on project location	
	• Notify Complete Streets email list and Community Stakeholder email list and post on Complete Streets website when MTB meeting materials are available for public review	
	• Link to agenda	
	• Provide information to public on how to provide public comment	
	• Send reminder to Community Stakeholders email lists 1 week before meeting	#####
	• Send reminder to Community Stakeholders email lists 1 day before meeting	#####
<b>Hold Multimodal Transportation Board Meeting</b>		
	• Make sure all attendees sign in; allow attendees to opt in for Complete Street updates	
	• Have sufficient staff available to address public questions and maintain focus on MTB purview	
<b>Multimodal Transportation Board Meeting Follow-up (1 week after Meeting)</b>		1/7/1900
	• After meeting, distribute MTB notes on all developer projects to Complete Streets and Community Stakeholder and post on Complete Streets website, note next steps in review process (if applicable)	

Planning Board Meeting Checklist		Date
Check when complete	<b>Planning Board Meeting Preparation (starting about 4 weeks before Meeting)</b>	#####
	•Enter meeting date in highlighted box (remaining dates will auto populate)	
	•Notify Complete Streets email list and Community Stakeholder email list and post on Complete Streets website when Planning Board meeting materials are available for public review	
	•Link to agenda and technical staff report	
	•Provide information to public on how to provide oral testimony	
	•Provide information to public on how to provide written testimony	
	•Send reminder to Community Stakeholders email lists 1 week before meeting	#####
	•Send reminder to Community Stakeholders email lists 1 day before meeting	#####
<b>Hold Planning Board Meeting</b>		
	•Make sure all attendees sign in; allow attendees to opt in for Complete Street updates	
	•Have sufficient staff available to address public questions and maintain focus on MTB purview	
<b>Planning Board Meeting Follow-up (starting 1 week after Meeting)</b>		1/7/1900
	•After meeting, distribute MTB notes on all developer projects to Complete Streets and Community Stakeholder and post on Complete Streets website, note next steps in review process (if applicable)	







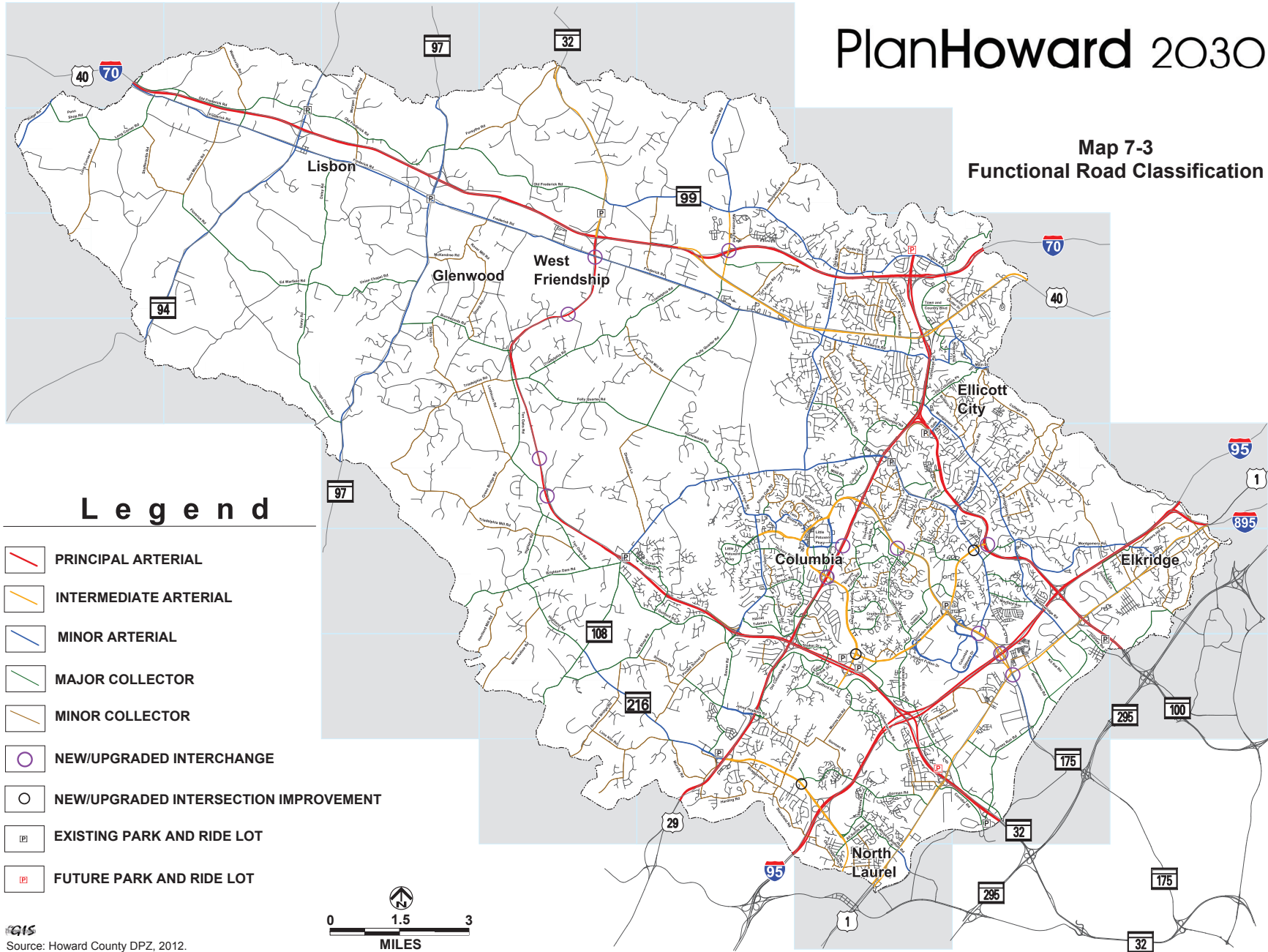

Second MTB Meeting Checklist		Date
Check when complete	<b>Multimodal Transportation Board Meeting Preparation (4 weeks before Meeting)</b>	#####
	•Enter meeting date in highlighted box (remaining dates will auto populate)	
	•Refine and expand description of project, provide overview of existing adjacent multimodal facilities, and overview of planned multimodal facilities included in WalkHoward and BikeHoward	
	•Notify Complete Streets email list and Community Stakeholder email list and post on Complete Streets website when MTB meeting materials are available for public review	
	•Link to agenda and presentation	
	•Link to Development Project Report	
	•Provide information to public on how to provide oral testimony	
	•Provide information to public on how to provide written testimony	
	•Send reminder to Community Stakeholders email lists 1 week before meeting	#####
	•Send reminder to Community Stakeholders email lists 1 day before meeting	#####
<b>Hold Multimodal Transportation Board Meeting</b>		
	•Make sure all attendees sign in; allow attendees to opt in for Complete Streets updates	
	•Have sufficient staff available to address public questions and maintain focus on MTB purview	
<b>Multimodal Transportation Board Meeting Follow-up (1 week after Meeting)</b>		1/7/1900
	•After meeting, distribute MTB notes on all developer projects to Complete Streets and Community Stakeholder and post on Complete Streets website, note next steps in review process (if applicable)	
	•Notify Complete Streets email list and Community Stakeholder email list and post on Complete Streets website when MTB meeting materials are available for public review	

# PlanHoward 2030

Map 7-3  
Functional Road Classification



## Legend

-  PRINCIPAL ARTERIAL
-  INTERMEDIATE ARTERIAL
-  MINOR ARTERIAL
-  MAJOR COLLECTOR
-  MINOR COLLECTOR
-  NEW/UPGRADED INTERCHANGE
-  NEW/UPGRADED INTERSECTION IMPROVEMENT
-  EXISTING PARK AND RIDE LOT
-  FUTURE PARK AND RIDE LOT





## Street Type – Function Classification Correlation Chart

Proposed Street Type	Functional Classification
Boulevard	Minor Arterial
Town Center Connector	Major Collector
Town Center Street	Minor Collector
Parkway	Intermediate Arterial
Neighborhood Connector	Major Collector
Neighborhood Street 1	Minor Collector
Neighborhood Street 2	Minor Collector
Neighborhood Yield Street	Local Road
Alley	Local Road
Industrial Street	Local Road
Country Road	Major Collector Minor Collector
Rural Development Street	Local Road

Notes:

1. Prior to assignment of functional classification by the Office of Transportation, new streets will have an assumed functional classification as described by this table.
2. Existing streets, regardless of their physical characteristics, have a functional classification as defined by the latest Howard County General Plan, Functional Road Classification map, which shall not be amended by reference to this table.
3. This table shall not be used to identify the required pavement section for a new street. New street type pavement sections are defined in Volume IV.
4. Where the Howard County Design Manual references a functional classification and no reference is made to street type, and no functional classification has been otherwise assigned, the designer shall use this table to identify the appropriate functional classification associated with the corresponding proposed street type.

# CHAPTER 2

## Street Design

<b>2.1 GENERAL</b>		<b>2.5 DRIVEWAYS</b>	
A. Introduction.....	2-1	A. General .....	2-89
B. Street Classifications and Functions .....	2-1	B. Residential .....	2-89
C. Network Connectivity.....	2-1	C. Commercial – Industrial and Multi-family ...	2-90
D. Design Controls.....	2-1	D. Spacing and Corner Clearance .....	2-90
E. Sight Distance .....	2-5	E. Sight Distance .....	2-91
F. Maintenance of Traffic.....	2-7	F. Grade .....	2-91
		G. Auxiliary Lanes.....	2-91
<b>2.2 TYPICAL SECTION ELEMENTS</b>		H. Sidewalks and Shared Use Paths .....	2-92
A. General.....	2-8	I. Pavement Markings .....	2-93
B. Sidewalks .....	2-9		
C. Shared Use Paths .....	2-10	<b>2.6 PARKING REQUIREMENTS AND OFF-STREET PARKING LOTS</b>	
D. Bicycle Facilities.....	2-13	A. General .....	2-94
E. Travel Lanes.....	2-25	B. Residential Parking .....	2-94
F. Street Trees.....	2-45	C. Off-Street Parking Lots.....	2-94
G. Minimum Edge Distance to Any Roadside Appurtenance.....	2-45	D. Bicycle Parking.....	2-96
H. Accommodation of Utilities in Typical Sections .....	2-45	E. Perpendicular Parking.....	2-96
I. Accommodation of Stormwater Management in Typical Sections.....	2-46		
		<b>2.7 STREET LIGHTING</b>	
<b>2.3 GEOMETRIC DESIGN</b>		A. Design and Installation.....	2-97
A. Horizontal Alignment .....	2-47	B. General Street Light Guidelines .....	2-98
B. Vertical Alignment .....	2-53	C. Parking Lot/Area Lighting.....	2-99
<b>2.4 INTERSECTION DESIGN</b>		<b>2.8 DETAILED DESIGN ELEMENTS</b>	
A. General.....	2-59	A. Alleys.....	2-100
B. Geometric Design.....	2-59	B. Private Streets.....	2-100
C. Roundabouts.....	2-69	C. Curb and Gutter .....	2-100
D. Alternative Intersection Types .....	2-71	D. Side Slopes .....	2-100
E. Pedestrian Design Elements at Intersections .....	2-71	E. Traffic Barrier .....	2-101
F. Shared Use Paths at Intersections .....	2-77	F. Underdrain .....	2-101
G. Bicycle Facilities at Intersections.....	2-78	G. Ditches .....	2-101
H. Transit Facilities at Intersections .....	2-86	H. Staged Construction.....	2-102
I. Right-of-Way .....	2-86	I. Bus Stops.....	2-102
J. Major Intersection Design Procedures .....	2-87	J. Scenic Roads .....	2-103
K. Minor Intersection Design Procedures .....	2-88	K. Mailbox Placement.....	2-104
L. Intersections with State Highways.....	2-88	L. Solid Waste Containerization .....	2-104
M. Intersections with Existing Streets.....	2-88		
		<b>2.9 REFERENCES.....</b>	<b>2-106</b>
		<b>APPENDICES.....</b>	<b>2-108</b>
		A. Public Roadway Design Criteria	
		B. Horizontal Circular Curve	
		C. Vertical Curve	
		D. Types of Vertical Curves	
		E. Method of Attaining Superelevation	
		F. Traffic Barrier Required for Embankment Geometry	
		G. Parking Stall Layout Elements	
		H. Intersection Sight Distance	
		I. Sidewalk Expansion Policy	

## 2.1 General

### A. Introduction

This chapter presents requirements, criteria, and guidelines for the design of streets, shared use paths, walking facilities, and bicycling facilities, driveways, entrances, and parking. The criteria have been developed considering the intended role of the street in relation to safety for all modes of travel, service function, land use, traffic demand, quality of service, economy, and the environment. For scenic roads, deviations from the basic design criteria set forth in this chapter may be warranted in order to preserve the scenic features of the road.

Street design must consider the needs of all users, whether traveling by foot, bike, motor vehicle, or transit, to travel with safety, comfort, and convenience. Street design standards permit streets to be designed so as to reduce speeds and allow for ease of maneuvering at those reduced speeds, while providing opportunities for greater flexibility and creativity for subdivision development.

The opportunities to enhance design relate to: improved walking and bicycling experience; reduced impacts on sensitive environmental features (streams, wetlands, floodplains, steep slopes, forests); preservation of site amenities like specimen trees, vistas, historic features; and creation of meaningful community open spaces and visual focal points that will help define a unique, attractive neighborhood. Residential streets are to be designed as low-stress streets that discourage their use for motor vehicle through traffic while encouraging active transportation modes including walking and bicycling. Speed is controlled by changes to alignment, lane width, maximum tangent length and/or speed control devices. Speed control devices and visual cues that change how drivers perceive the roadway are introduced into the street design to encourage appropriate driver behavior.

### B. Street Classifications and Functions

For basic design of streets, use the Street Types described in detail in Section 1.3.C.

### C. Network Connectivity

The Traditional Neighborhood uses a grid system of streets with multiple routes that residents can access, supporting multimodal network connectivity and better distribution of traffic volumes. The street widths and other parameters can be customized with the permission of both DPZ and DPW. However, the design has many aspects that make up the whole. The resultant layout and templates must work together. The basic objectives of the Design Manual Volume III must still be met, including safety, on-street parking, speed control, access, fire and rescue access, and trash pick-up.

### D. Design Controls

The principal elements controlling design of streets are design hourly traffic volumes and projected or anticipated average daily traffic for all modes of travel, target speed for multimodal safety, design speed, design users representing all modes, design and control vehicles, future multimodal traffic volumes, community context, and impacts to adjacent land. These elements form the basis for the selection of the geometric elements that are required to accommodate the anticipated traffic at desired levels of safety, comfort, and convenience.

#### 1. Design Hourly Volume

Design hourly volume is a volume determined for use in design representing motor vehicle traffic expected to use the street. DHV is discussed in Chapter 5 and the Designer is referred thereto for its determination and use.

## 2. Target Speed and Design Speed

The **Target Speed** of a street is the desired speed at which motor vehicle drivers should operate to maintain safety, comfort, and convenience for all users of the street to the greatest extent possible. The target speed should be appropriate with respect to the users of the facility, the adjacent land use, and the street type. Lower speeds increase safety for all street users, especially people who walk and bike. Therefore, they are especially desirable in areas where people walking and bicycling are present, and the desire for lower speeds should influence the selection of target speed. The target speed is intended to be used as the posted speed. Target speed is obtained by providing a roadway typical section and environment that is *self-enforcing*, that is, the roadway features encourage compliance with the target speed of the roadway. Strategies for designing a road to target speed include lane narrowing, implementation of speed management measures, absence of superelevation, and provision of a sense of enclosure.

The **Design Speed** of a street is a selected speed used to determine its various primary geometric design features, including but not limited to minimum horizontal curvature, sight distance between motorists and all users of the street, sight distance to objects in the roadway, and roadside barrier design. Historically, design speeds have been selected to maximize the mobility of motorists, and roadway features have been designed to accommodate vehicular operating speeds. To balance the needs of all users, the design speed of new Howard County streets will be correlated to the desired target speed as shown in Table 2-1.

For projects on existing roadways where improvements are not expected to influence the current operating speed, a speed study is required to determine the operating speed and thus the design speed that should be used. Where excessive speed is a concern, the project scope should consider implementing speed management measures to result in a desired target speed. Similarly, when a new street connects to an existing County roadway, the existing roadway operating speed must be determined to analyze sight distance at the intersection. When a portion of a roadway is being reconstructed or improved, the target speeds and design speeds should be selected based on the street types, and if necessary, appropriate transitional elements should be introduced on the approach to the reconstructed street to slow drivers to the target speed. For instance, a desired speed reduction on a transition from an area with little pedestrian and bicycle activity to a more developed area where pedestrian and bicycle use is expected should occur outside of the higher activity area such that the target speeds are achieved prior to motorists entering the higher activity area.

**TABLE 2-1**  
**STREET TYPE TARGET SPEEDS AND DESIGN SPEEDS**

Street Type	Target Speed (mph)	Design Speed (mph)
Boulevard	25	30
Town Center Connector	25	30
Town Center Street	25	30
Parkway*	varies	varies
Neighborhood Connector	30	35
Neighborhood Street 1	25	30
Neighborhood Street 2	25	25
Neighborhood Yield Street	25	25
Alley	15	15
Industrial Street	25	25
Country Road*	varies	varies
Rural Development Street	25	25

\* Consult with Howard County Department of Public Works to establish target speed and design speed.

### 3. Design Vehicle and Control Vehicle

Dimensions and turning characteristics of all design vehicles can be found in AASHTO's "A Policy on Geometric Design of Highways and Streets," 2018 or latest edition. This publication will be referred to throughout this chapter as the "Green Book" (Ref. 1).

The "Green Book" divides vehicles into four general classes, including (1) passenger cars, (2) buses, (3) trucks, and (4) recreational vehicles. The passenger-car classes include passenger cars of all sizes, minivans, vans, sport utility vehicles of all sizes, and pick-up trucks of all sizes. Buses include motor coaches, city transit including articulated, and school buses. Trucks includes single-unit trucks, tractor-semitrailer combinations, and tractors with semitrailers in combination with full trailers. Recreational vehicles include passenger cars with camp trailers, passenger cars with boat trailers, motor homes, motor homes with boat trailers, and motor homes towing a car.

Typical vehicles have been developed for each of the classes. The respective design vehicles have dimensions and a minimum turning radius larger than most vehicles in their class. Although a bicycle is also considered a design vehicle for the purposes of designing shared use paths and other bicycle facilities as discussed in Section 2.2.C and 2.2.D, it is not included in the below list.

The designations for design and control vehicles are as follows:

P	(passenger car)
SU	(single unit truck)
SU-30	(30-foot single unit truck)
SU-40	(40-foot single unit truck)
SU-50	(50-foot single unit truck)
BUS-40 & BUS-45	(motor coaches)
CITY-BUS	(city transit bus)
S-BUS 36	(conventional school bus 65 passenger)
S-BUS 40	(large school bus 84 passenger)
A-BUS	(articulated bus)
WB-40	(intermediate tractor-semitrailer combination)
WB-50	(large tractor-semitrailer combination)
WB-62	(interstate tractor- full trailer combination)
WB-67	(interstate tractor-full trailer combination)
WB-109	(turnpike tractor-semitrailer-semitrailer combination)
MH	(motorhome)
P/T	(passenger car-camp trailer)
P/B	(passenger car-boat trailer)
MH/B	(motor home with boat trailer)

The selection of appropriate turning vehicles is very important in the design of streets and intersections. Intersection corner radii should be as minimal as possible while adequately accommodating appropriate vehicle types. Tighter corner radii reduce the speeds of turning vehicles and reduce crosswalk lengths, both of which improve the safety of people walking and bicycling.

In the design of streets and intersections, the Designer should consider both a design vehicle and a control vehicle. The **design vehicle** is a vehicle that is likely to use the street or turn at the intersection regularly throughout the day. The design vehicle should be able to turn from one street to another without crossing from one lane into another. On the other hand, a **control vehicle** is a vehicle that may occasionally use a street. As shown in Figure 2-1, control vehicles may leave their lane on either street while making a turn. Section 2.4.B.4 provides further information about intersection design relative to design and control vehicles.

Figure 2-1. Design Vehicle vs. Control Vehicle.

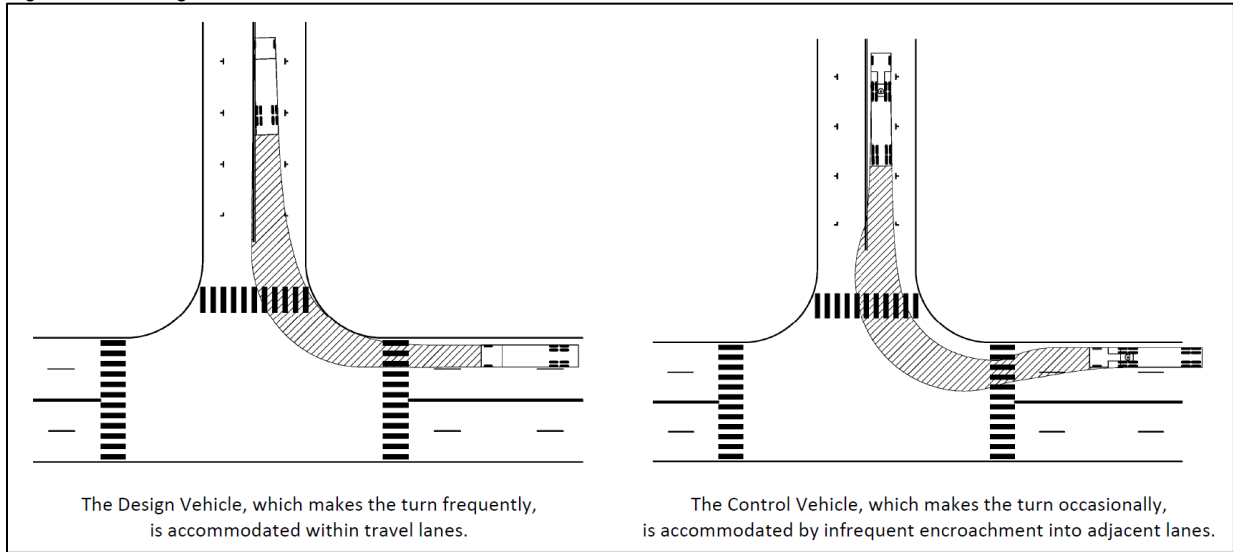

Source: Institute of Transportation Engineers (ITE) "Traffic Engineering Handbook, 7th Edition," 2016 (Ref. 2)

On Howard County roadways, the vehicles in Table 2-2 should typically be used for design. Design vehicles include Passenger cars (P), SU-40 vehicles, and WB-62 vehicles. The smallest control vehicle to be evaluated in Howard County is a BUS-40 vehicle, representing a fire truck; this vehicle may be assumed to use the entire roadway footprint to make turns if needed. Although these vehicles are provided for typical design situations, it is incumbent upon the designer to evaluate the likely vehicles that will use a facility and propose alternate design vehicles as required.

**TABLE 2-2**  
**STREET TYPE DESIGN AND CONTROL VEHICLES**

Street Type	Design Vehicle	Control Vehicle
Boulevard	SU-40	WB-50
Town Center Connector	SU-40	BUS-40
Town Center Street	SU-40	BUS-40
Parkway	WB-62	N/A
Neighborhood Connector	SU-40	BUS-40
Neighborhood Street 1	SU-40	BUS-40
Neighborhood Street 2	SU-40	BUS-40
Neighborhood Yield Street	P	BUS-40
Alley	P	BUS-40
Industrial Street	WB-62	N/A
Country Road	SU-40	N/A
Rural Development Street	P	BUS-40



## E. Sight Distance

Sight distance is the length of visible roadway ahead of the driver. The three types of sight distance considered in design are stopping sight distance, passing sight distance and intersection sight distance. Sight distance shall be made as long as feasible, but never less than the stopping sight distance.

### 1. Stopping Sight Distance

Stopping sight distance (SSD) is the distance required for a vehicle to stop before reaching an object in its path. It is the sum of the distance traveled from the moment the object is first visible to the driver to the moment the brakes are applied, and the distance required to stop after the brakes are applied. When calculating SSD, the design speed should be used.

Stopping sight distance is measured between an eye height of 3.5 feet and an object height of 2.0 feet.

The equation for stopping sight distance is as follows:

$$SSD = 1.47Vt + \frac{V^2}{30\left(\left(\frac{a}{32.2}\right) \pm G\right)}$$

Where  
 V = initial speed (mph)  
 t = brake reaction time, 2.5 s  
 a = deceleration rate, ft/s<sup>2</sup>, 11.2 ft/s<sup>2</sup>  
 G = percent of grade divided by 100

Table 2-3 consists of computed distances for wet pavements for various speeds and grades.

**TABLE 2-3**  
**STOPPING SIGHT DISTANCE**

Design Speed (mph)	Level (ft)	Downgrades			Upgrades		
		-3% (ft)	-6% (ft)	-9% (ft)	+3% (ft)	+6% (ft)	+9% (ft)
15	80	80	82	85	75	74	73
20	115	116	120	126	109	107	104
25	155	158	165	173	147	143	140
30	200	205	215	227	200	184	179
35	250	257	271	287	237	229	222
40	305	315	333	354	289	278	269
45	360	378	400	427	344	331	320
50	425	446	474	507	405	388	375
55	495	520	553	593	469	450	433
60	570	598	638	686	538	515	495
65	645	682	728	785	612	584	561
70	730	771	825	891	690	658	631

Reference: "Green Book" Table 3-1, *Stopping Sight Distance on Level Roadways* and Table 3-2, *Stopping Sight Distance on Grades* (Ref. 1)

The relationships between horizontal curvature and sight distance are given in Section 2.3.A.1.f, and the relationships between vertical curvature and sight distance are given in Section 2.3.B.2. Stopping sight distance for shared use paths is discussed in Section 2.2.C.

## 2. Passing Sight Distance

Passing sight distance (PSD) is the distance required for a vehicle to pass another before meeting an opposing vehicle which might appear after the pass began. It is applicable only to two-lane, two-way rural major collectors and minor arterials. Passing sight distance is measured between an eye height of 3.5 feet and an object height of 3.5 feet.

The minimum passing sight distance as reflected in Table 2-4 shall be provided at least once per mile.

**TABLE 2-4  
MINIMUM PASSING SIGHT DISTANCE**

Design Speed (mph)	Assumed Speeds (mph)		Minimum Passing Sight Distance (ft)
	Passed Vehicle	Passing Vehicle	
20	8	20	400
25	13	25	450
30	18	30	500
35	23	35	550
40	28	40	600
45	33	45	700
50	38	50	800
55	43	55	900
60	48	60	1000
65	53	65	1100
70	58	70	1200

Reference: "Green Book" Table 3-4, *Passing Sight Distance for Design of Two-Lane Highways* (Ref. 1)

## 3. Intersection Sight Distance

Adequate sight distance shall be provided for all turning movements for all types of intersections. Intersection sight distance is measured using a height of eye of 3.5 feet and height of object of 3.5 feet. The distance is measured from a point 10 feet back from the edge of the pavement or flow line of the major street. For existing streets, the operating speed (85<sup>th</sup> percentile) along the existing street shall be utilized in the analysis. For proposed streets, the design speeds provided in Section 2.1.D.2 shall be utilized in the analysis. Procedures for measuring intersection sight distance shall be performed as prescribed in "Green Book Chapter 9 – Intersections - 9.5 Intersection Sight Distance" (Ref. 1).

In addition to providing intersection sight distance, at all intersections, the major street shall meet the stopping sight distance criteria with a height of eye of 3.5 feet on the major street and 2-foot object at the intersection of the major and minor street. See Section 2.1.E.1 for stopping sight distance criteria.

In residential areas where the major street is classified as minor collector or below, stopping sight distance may be used on the major street in lieu of meeting both intersection sight distance and stopping sight distance. Also, the driver waiting at the minor street shall be required to have a continuous unobstructed view of the approaching vehicle on the major street. The obstructed view is based the height of eye at 3.5 feet at 10 feet back from the edge of the pavement or flow line of the major street and a 2-foot object at the point on the major street at the location of the Stopping Sight Distance on the major. See Appendix H for additional details of Intersection Sight Distance in Residential Areas when major street classification is equal to or less than a minor collector.

In areas where on-street parking is permitted, parking should be set back in advance of any crosswalk to allow “daylighting,” or clear visibility between people driving and those using the crosswalk. Howard County Code and Maryland Vehicle Law govern parking setbacks on County streets. These setbacks are sufficient in most circumstances, but site-specific conditions shall be evaluated by the Designer to determine whether a larger setback is needed when a curb extension is designed. Curb extensions should be provided in these daylighted areas to shorten crosswalk lengths, reinforce parking restrictions, and further improve sight distance.

For intersection sight distance considerations between Shared Use Paths, roadways, and sidewalks, see MDOT SHA’s “Bicycle Policy Design Guidelines” (Ref. 3). For intersection sight distance guidelines for mid-block pedestrian crossings, see MDOT SHA’s “Accessibility Policy & Design Guidelines for Pedestrian Facilities Along State Highways” (Ref. 4).

## **F. Maintenance of Traffic**

When designing either an improvement of an existing street or a new street, consideration must be given to maintaining access for all modes of transportation, including pedestrians, bicyclists, and vehicles during construction. Specific guidance for maintenance of traffic is provided in Section 5.5.

Maintenance of traffic plan shall be in accordance with the Federal Highway Administration’s “Manual on Uniform Traffic Control Devices 2009 with Revision Numbers 1 and 2” (2012) or latest edition (Ref. 5), MDOT SHA “Book of Standards Temporary Traffic Control Devices Typical Applications” (Ref. 6), and Howard County Standard Details and Specifications.

## 2.2 Typical Section Elements

### A. General

Typical sections for the various street types are shown in Section 1.3.C and the Standard Details of Volume IV of the Design Manual and include:

- Boulevard
- Town Center Connector
- Town Center Street
- Parkway
- Neighborhood Connector
- Neighborhood Street 1
- Neighborhood Street 2
- Neighborhood Yield Street
- Alley
- Industrial Street
- Country Road
- Rural Development Street

Typical section elements consist of facilities for all modes of travel as illustrated in Figure 2-2 and addressed in the following sections.

- Sidewalks
- Shared use paths (for both walking and bicycling)
- Bicycle facilities
- Travel lanes

Figure 2-2. Typical Section Elements.



## B. Sidewalks

Regulations governing the placement of sidewalks for new developments are contained in the “Subdivision and Land Development Regulations” and in Section 1.3.C. Those areas normally requiring sidewalks are so indicated on the typical sections.

Standard sidewalk locations are shown on the Typical Sections. Keeping sidewalks at a consistent distance from the curb, either straight or following the curvature of the street, maximizes predictability for people with visual impairments. However, the Designer has the option to vary the distance between the sidewalk and the curb to avoid constraints such as trees, steep slopes, etc. If the sidewalk is moved closer to the street than is shown on the typical sections, the Designer shall determine alternative placement of street trees in consultation with Department of Public Works, Traffic Engineering Division.

Sidewalks shall have a maximum cross slope (perpendicular to the direction of travel) of 2 percent. A cross slope of 2 percent is preferred to shed water runoff. Sidewalks shall have a smooth, slip-resistant surface. All sidewalks shall meet the accessibility requirements of the Americans with Disabilities Act (ADA).

Sidewalk width is dependent on anticipated demand for walking. In most suburban areas, the preferred sidewalk width shall be 5 feet. This is the minimum width to be provided unless there are extreme constraints, such as construction in an historic district or adjacent to an historic structure. Upon approval of an exception as described in Section 1.2.F, a 4-foot-wide sidewalk may be provided in those circumstances. In that case, passing areas at least 5 feet wide and 5 feet long must be provided no more than 200 feet apart to allow for two wheelchair users to pass each other. In no case will sidewalks narrower than 4 feet be permitted along a corridor. While provision of a buffer between the sidewalk and curb is preferred, a sidewalk at the back of curb is preferable to no sidewalk at all and may be required in constrained conditions. When placed adjacent to curbs, sidewalks should be a minimum of 6 feet wide.

While the designer must strive to eliminate obstructions from the clear sidewalk width, in some circumstances it is impractical to locate items such as utility poles, signal cabinets, mailboxes, etc., outside of the sidewalk area. In these cases, an isolated pinch point of 36” may be provided, but a clear, ADA compliant path for the sidewalk user to navigate the alignment must be available.

In mixed use areas, sidewalks must accommodate more people walking as well as other functions illustrated in Figure 2-3. The Typical Sections show a minimum 5-foot sidewalk within the County right of way. To accommodate additional uses, additional hardscape shall be provided outside the right of way. Users will experience this hardscape as a sidewalk, but it will be privately owned and maintained. Section 1.3.C, Street Types and Volume IV provide additional clarification on what portion of the street is public and what is private.

Figure 2-3. Sidewalk Zones.

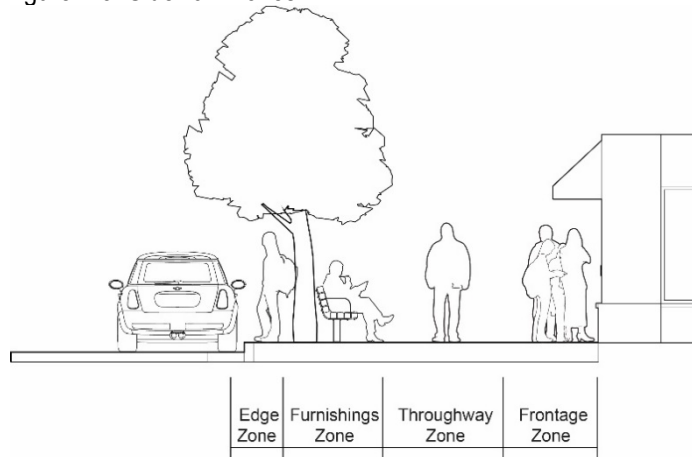

Source: Modified from the Institute of Transportation Engineers

Considerations for sidewalks across driveways are provided in Section 2.5.H.

A sidewalk expansion policy, established through Executive Order 2020-16 on October 6, 2020, provides the procedure for communication with adjacent property owners regarding new sidewalk segments on public property along County streets. Advance notification is provided to adjacent property owners in four cases: (1) the sidewalk is in the Pedestrian Master Plan, (2) the sidewalk is within walking distance of a public school, (3) the sidewalk is an extension requested by the County as part of a development project, or (4) the sidewalk has been identified by the Office of Transportation as required for safe access to a transit stop, commercial or institutional use, park, sidewalk, pathway, or other public facility. In these four circumstances, the County may inform the property owner that a sidewalk will be built and does not have to put the issue to a vote. In all other cases, the local community must express their support for the sidewalk through a vote to be administered by the County. Two-third majority support of the households that submit a vote is required to support sidewalk installation. The full policy is provided in Appendix I.

### C. Shared Use Paths

Detailed guidance on the design of shared use paths is provided in the AASHTO “Guide for the Development of Bicycle Facilities,” commonly known as the “Bike Guide” (Ref. 7). According to the 4th Edition of the “Bike Guide,” “Shared use paths are bikeways that are physically separated from motorized vehicular traffic by an open space or barrier and either within the highway right-of-way or within an independent right-of-way.”

#### 1. Accessibility

The name “shared use” indicates that these paths are shared by people walking and bicycling. For that reason, shared use paths shall comply with ADA accessibility requirements. The maximum cross slope of a shared use path shall be 2 percent. The path shall have a smooth, slip-resistant surface. Curb ramps shall be ADA compliant. Driveway crossings shall be designed in accordance with Section 2.5.H. Designers should follow the “Supplemental Notice on Shared Use Paths” released by the U.S. Access Board (Ref. 8).

#### 2. Cross Section

A shared use path width of ten feet is the minimum County pathway width, intended to minimize conflicts between people walking and bicycling. The Federal Highway Administration (FHWA) “Shared-Use Path Level of Service Calculator” referenced in Section 1.3.E may recommend an even wider path in areas with high existing or anticipated walking and bicycling activity (Ref. 9). By contrast, in constrained areas, a narrower path width may be considered.



The “Bike Guide” provides the following guidance for consideration of narrower shared use paths:

“In very rare circumstances, a reduced width of 8 ft (2.4 m) may be used where [any of] the following conditions prevail:

- A path width of 8 ft (2.4 m) may be used for a short distance due to a physical constraint such as a regulated environmental feature, bridge abutment, utility structure, fence, and such.
- Horizontal and vertical alignments provide frequent, well-designed passing and resting opportunities.
- The path will not be regularly subjected to maintenance vehicle loading conditions that would cause pavement edge damage.

Wider paths may also be considered to accommodate occasional use by larger maintenance vehicles to adjoining features such as stormwater management facilities.

A graded area with a maximum side slope of 6:1 should be provided adjacent to both sides of the path. This area should be a minimum of 2 feet wide, though 3-5 feet in width is desirable. Where steeper drop-offs are present adjacent to the path, the “Bike Guide” provide guidance on when railings should be used and how they should be placed.

Vertical objects such as signs, tree trunks, and fences should be a minimum of 2 feet from the edge of the path. Signs must maintain a minimum clearance of 7 feet from the bottom of the sign to the pathway surface. Where such clearance cannot be provided for vertical objects such as tree trunks or fences, traffic control devices such as delineators or signs should be used to warn path users of the presence of the object.

The minimum vertical clearance from the surface of path to an overhead obstruction should be 10 feet. This may be reduced to 8 feet in constrained circumstances. Greater vertical clearance should be considered where maintenance vehicles or emergency vehicles may use the path.

### 3. Target Speed

In most circumstances in Howard County, a target speed of 18 mph should be used for shared use paths. Long grades may warrant a higher design speed for the downhill direction, while shared use paths in more developed areas with a greater mix of users may be designed for a lower speed. Target speed may be reduced to 15 mph or 12 mph if a high percentage of pedestrian path users is anticipated.

### 4. Horizontal Alignment

The standard location of shared use paths is shown in section 1.3.C Street Types. The horizontal alignment is established by keeping shared use paths at a consistent distance from the curb, either straight or following the curvature of the street. This also maximizes predictability for people with visual impairments.

Sometimes, site constraints do not accommodate a shared use path adjacent to the street. In these instances, the Designer may identify an independent right-of-way that provides the desired connectivity for people walking and bicycling.

For shared use paths that are not aligned based on the adjacent roadway, the horizontal alignment is determined by a typical adult bicyclist who leans into turns. Using a maximum 20-degree lean angle, the “Bike Guide” recommends the minimum radii in Table 2-5 for a variety of design speeds.

**TABLE 2-5  
MINIMUM RADII FOR HORIZONTAL CURVES ON SHARED USE PATHS**

Target Speed (mph)	Minimum Radius (ft)
12	27
14	36
16	47
18	60
20*	74
25*	115
30*	166
*These speeds and the resulting radii are intended for use on long grades where inexperienced bicyclists may reach higher rates of speed.	

## 5. Vertical Alignment

As described in the “Bike Guide,” “The maximum grade of a shared use path adjacent to a roadway should be 5 percent, but the grade should generally match the grade of the adjacent roadway. Where a shared use path runs along a roadway with a grade that exceeds 5 percent, the [path] grade may exceed 5 percent but must be less than or equal to the roadway grade. Grades on shared use paths in independent [alignments where the grade does not follow a roadway grade] should be kept to a minimum, especially on long inclines. Grades steeper than 5 percent are undesirable because the ascents are difficult for many path users, and the descents cause some users to exceed the speeds at which they are competent or comfortable.” At ramps, slope may exceed the roadway slope, but not exceed 8.33%.

Stopping sight distance for shared use paths is calculated in a similar manner to the method described in Section 2.1.E. This is expressed as:

$$S = (V^2 / (30 (f +/- G))) + 3.67 V, \text{ where}$$

S = stopping sight distance (ft)

V = speed (mph)

F = coefficient of friction (use 0.16 for a typical bicyclist in wet conditions)

G = grade (ft/ft)

The *Bike Guide* provides graphs illustrating stopping sight distance vs grade in Figure 5-7, as well as methods to calculate crest vertical curve lengths in Table 5-5 and Figure 5-8.

## 6. Structures

Guidance for design of shared use path bridges is provided in Section 3.6. Guidance for design of shared use path underpasses is provided in Section 3.7.

## 7. Intersections

Considerations for design of shared use path intersections are found in Section 2.4.F.

## 8. Signing and Pavement Markings

Signing and pavement markings for shared use paths shall be in accordance with Chapter 9 of the “Maryland Manual on Uniform Traffic Control Devices” (MdMUTCD) (Ref. 10). It is preferred that shared use paths in Howard County implement centerline markings.

## D. Bicycle Facilities

Bicycle facilities are designed for the exclusive use of people bicycling, as opposed to shared use paths that may be used by people walking and bicycling. As described in the sections below, there are a variety of bicycle facilities to fit a variety of contexts. Bicycle facilities at intersections are defined in Section 2.4.G. Signing and pavement markings for these facilities shall be in accordance with Chapter 9 of the MdMUTCD (Ref. 10). Detailed design guidance is available within the following documents as referenced further in the below sections:

- “Bicycle Policy Design Guidelines,” MDOT SHA (Ref. 3)
- “Guide for the Development of Bicycle Facilities,” AASHTO (Ref. 7)
- “Bikeway Selection Guide,” FHWA (Ref. 11)
- “Urban Bikeway Design Guide,” NACTO (Ref. 12)
- “Separated Bike Lane Planning and Design Guide,” FHWA (Ref. 13)

### 1. Facility Types

a. One-Way Separated Bike Lanes

One-way separated bike lanes are physically separated from adjacent motor vehicle lanes. The separation must be physical rather than simply pavement markings. Physical separation increases both safety and comfort for people bicycling.

Selection of the appropriate type of separation is based on sight distance, available space, cost, maintenance considerations, and engineering judgement. Types of separation may include the following.

- Curbed cast-in-place concrete curb or island
- Flexible delineator posts that are fixed to the pavement
- On-street parking, often in conjunction with one of the other separation methods described above

The preferred width of a one-way separated bike lane is 6.5 feet. This width allows two people to bicycle side by side or for one person to bicycle past another while traveling in the same direction. In constrained conditions, the width of the one-way separated bike lane may be reduced to 5 feet. Buffer separation between the separated bike lane and motor vehicle lanes is generally 3 feet. A wider separation may be desirable adjacent to on-street parking to allow more space for passenger doors to open while minimizing conflicts with people bicycling.

Figure 2-4. One-Way Separated Bike Lane.

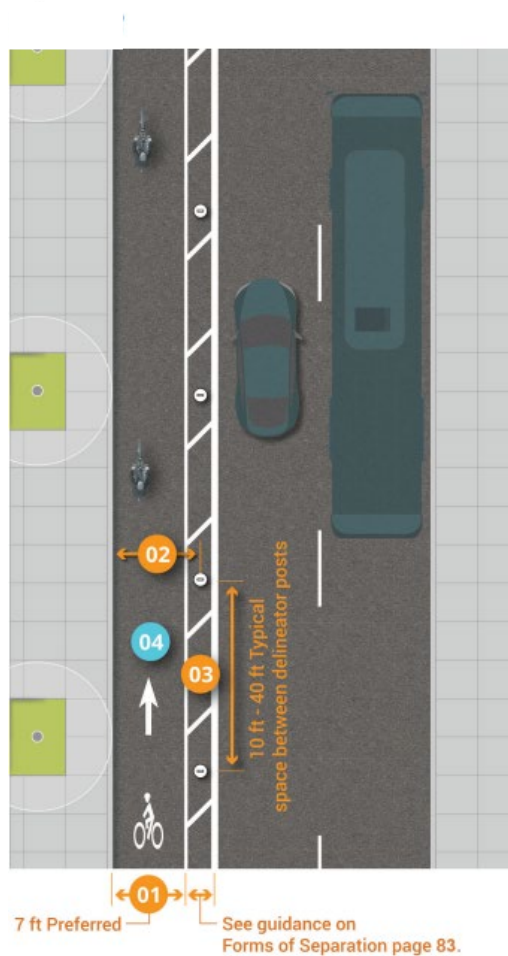

- 01 One-way separated bike lanes should have a minimum width of 5 ft. Wider separated bike lanes provide additional comfort and space for bicyclists and should be considered where a high volume of bicyclists is expected. Widths of 7 ft and greater are preferred as they allow for passing or side-by-side riding. Additional care should be taken with wider lanes such that the separated bike lane is not mistaken for an additional motor vehicle lane.
- 02 Total clear width between the curb face and vertical element should be at least the fleet maintenance (sweeping or snowplow) vehicle width. Widths (inclusive of the gutter pan and to the vertical buffer element) narrower than 7 ft will often require specialized equipment. Consultation with a Public Works department is recommended during the planning process.
- 03 A minimum 3 ft buffer should be used adjacent to parking. For further guidance on buffer selection and installation, see page 83.
- 04 For further guidance on typical signs and markings for separated bike lanes, see page 127.

Source: FHWA “Separated Bike Lane Planning and Design Guide” (Ref. 13)

## b. Two-Way Separated Bike Lanes

Like one-way separated bike lanes, two-way separated bike lanes are physically separated from adjacent motor vehicle lanes. They are designed exclusively for the use of people bicycling and should be paired with a sidewalk for people walking. For shared use paths that may accommodate both people walking and bicycling, see Section 2.2.C. The same types of separation provided for one-way separated bike lanes may be used for two-way separated bike lanes.

The preferred width of a two-way separated bike lane is 12 feet. This width allows two people to bicycle side by side while passing another person bicycling in the opposite direction. In constrained conditions, the width of the two-way separated bike lane may be reduced to 10 feet. In areas with low bicycle volumes, it is possible to put an 8' wide two-way separated bike lane on one side of the street in constrained locations, with future plans to place a second separated bike lane on the other side of the street (converting both to one-way separated bike lanes) when bicycling volumes increase in the future.

Buffer separation between the separated bike lane and motor vehicle lanes is generally 3 feet. A wider separation with raised curb may be desirable to accommodate signage and street lights closer to the travel lane. Adjacent to on-street parking, a wider separation may be desirable to allow more space for passenger doors to open while minimizing conflicts with people bicycling.

Two-way separated bike lanes create additional points of conflict as compared to one-way separated bike lanes. People bicycling against the flow of motor vehicle traffic are less likely to be detected by motorists than those bicycling in the same direction as motor vehicle traffic. Special care is needed for intersection and driveway design, as described in Section 2.4.G.2.

Figure 2-5. Two-Way Separated Bike Lane.



Source: FHWA “Separated Bike Lane Planning and Design Guide,” City of Austin



c. Buffered Bike Lanes

Buffered bike lanes provide a separation between motor vehicle traffic and bicycle traffic using a painted buffer rather than physical separation. While buffered bike lanes do not offer the same safety and comfort benefits as separated bike lanes, they are appropriate in some circumstances where motor vehicle speeds and volumes are relatively low. Where space permits, a buffered bike lane is preferred to a conventional (non-buffered) bike lane.

Buffered bike lanes are generally chosen where there is insufficient room for one-way separated bike lanes or where local conditions make provision of physical separation undesirable. The preferred width of a buffered bike lane is 6 feet, with a minimum width of 5 feet. Buffer width may vary, but a 2-foot or 3-foot buffer is desirable.

Figure 2-6. Buffered Bike Lane.



Source: Howard County



d. Conventional Bike Lanes

A conventional bike lane is delineated by a painted line between the bike lane and motor vehicle traffic. For that reason, conventional bike lanes offer even fewer safety comfort benefits than buffered bike lanes. However, in most circumstances they are preferable to no bicycle facilities at all.

The preferred width of a conventional bike lane is 6 feet from the face of curb, with a minimum width of 5 feet from the face of curb, which is consistent with guidance from MDOT SHA and AASHTO.

On streets with significant grades, speeds of people bicycling may be much slower in the uphill direction and downhill bicyclists may approach the speeds of motor vehicles. If there isn't room for bike lanes in both directions, this situation may warrant consideration of a bike lane only in the uphill direction, with shared lane markings in the downhill direction.

Figure 2-7. Conventional Bike Lane.



Source: Whitman, Requardt & Associates, LLP

## e. Shoulders

Paved shoulders function much like conventional bike lanes from the perspectives of safety and comfort. Unlike conventional bike lanes, parking is permitted in shoulders although it is infrequent. In rural locations, shoulders provide a location for bicyclists outside of the path of motor vehicle traffic. Refer to Figure 2-12 for guidance on the appropriate shoulder width.

Figure 2-8. Shoulder.



Source: Fairfax Alliance for Better Bicycling

## f. Bicycle Boulevards

Bicycle boulevards are routes along low-stress local streets that are designed to give bicycle travel priority. Bicycle boulevards may be designated using shared lane markings, signs, and speed management tools to discourage motor vehicle through trips. Because these streets are generally low-stress due to lower motor vehicle speeds, traffic calming measures as described in Section 2.2.E.10 may be used to maintain those low speeds.

Locations where bicycle boulevards cross higher-stress streets require special attention. Section 2.4.G.6 provides additional guidance. Crossing locations may be at signalized intersections or may include midblock crossings (see Section 2.4.G.5).

Figure 2-9. Bicycle Boulevard.



Source: NACTO



## g. Shared Lanes

As the name indicates, shared lanes are used both by people bicycling and driving. Safety and comfort of people bicycling in shared lanes is highly dependent on low motor vehicle speeds and volumes. The ranges of speed and volume where shared lanes may be appropriate are illustrated in Figure 2-11. Safety and comfort in shared lanes are also affected by the presence of on-street parking. The LTS guidance in Section 5.2.D indicates the combinations of prevailing speed and on-street parking that will result in lower-stress bicycling environments (LTS 2 or better).

Shared lane markings, also known as “sharrows,” may be used where prevailing motor vehicle speeds and street characteristics result in LTS 1 or 2 as described in Section 5.2.D. These markings serve two purposes: to help people driving understand that people may be bicycling along the street, and to assist people bicycling to use a desirable position in the lane, away from the doors of parked cars, where cyclists are visible to motorists, and where unsafe passing is discouraged.

According to the MdMUTCD, “If used in a shared lane with on-street parallel parking, Shared Lane Markings should be placed so that the centers of the markings are at least 11 feet from the face of curb, or from the edge of pavement where there is no curb. If used on a street without on-street parking that has an outside travel lane that is less than 14 feet wide, the centers of the Shared Lane Markings should be at least 4 feet from the face of the curb, or from the edge of the pavement where there is no curb. If used, the Shared Lane Marking should be placed immediately after an intersection and spaced at intervals not greater than 250 feet thereafter” (Ref. 10).

Figure 2-10. Shared Lane.



Source: Howard County

## 2. Selection of Appropriate Bicycle Facility Type

The concept of Level of Traffic Stress (LTS) for bicyclists and methods for calculating LTS are provided in Section 5.2.D. To summarize, LTS ranges from 1 (highest comfort) to 4 (highest stress). Generally speaking, the greater the separation between bicyclists and motor vehicle traffic and the lower the motor vehicle speed, the lower the LTS. As noted in Chapter 1, Howard County has identified LTS 1 or 2 as “low-stress,” and County streets are to be designed to meet LTS 2 or better whenever practical. LTS 1 is preferred near key destinations for children such as schools, parks, and libraries. Where LTS 1 or 2 cannot be readily provided, Section 1.3.E provides guidance for alternative design considerations.

For new streets, the Designer should use the Street Types in Section 1.3.C., which are designed to provide the appropriate LTS given the anticipated vehicular speed and volume. Bicyclists and motor vehicles share the lane in Neighborhood Yield Streets because they are very low-speed, low-volume roadways.

The FHWA “Bikeway Selection Guide” provides guidance for the selection of an appropriate bicycle facility type based on motor vehicle volume and speed for both urban/suburban (Figure 2-11) and rural (Figure 2-12) contexts (Ref. 11). While this guidance is generally consistent with the LTS methodology, there are some differences. The Designer shall consider both the figures below and the calculated LTS, ensuring that the appropriate LTS is provided.

Figure 2-11. Preferred Bikeway Type for Urban/Suburban Contexts.

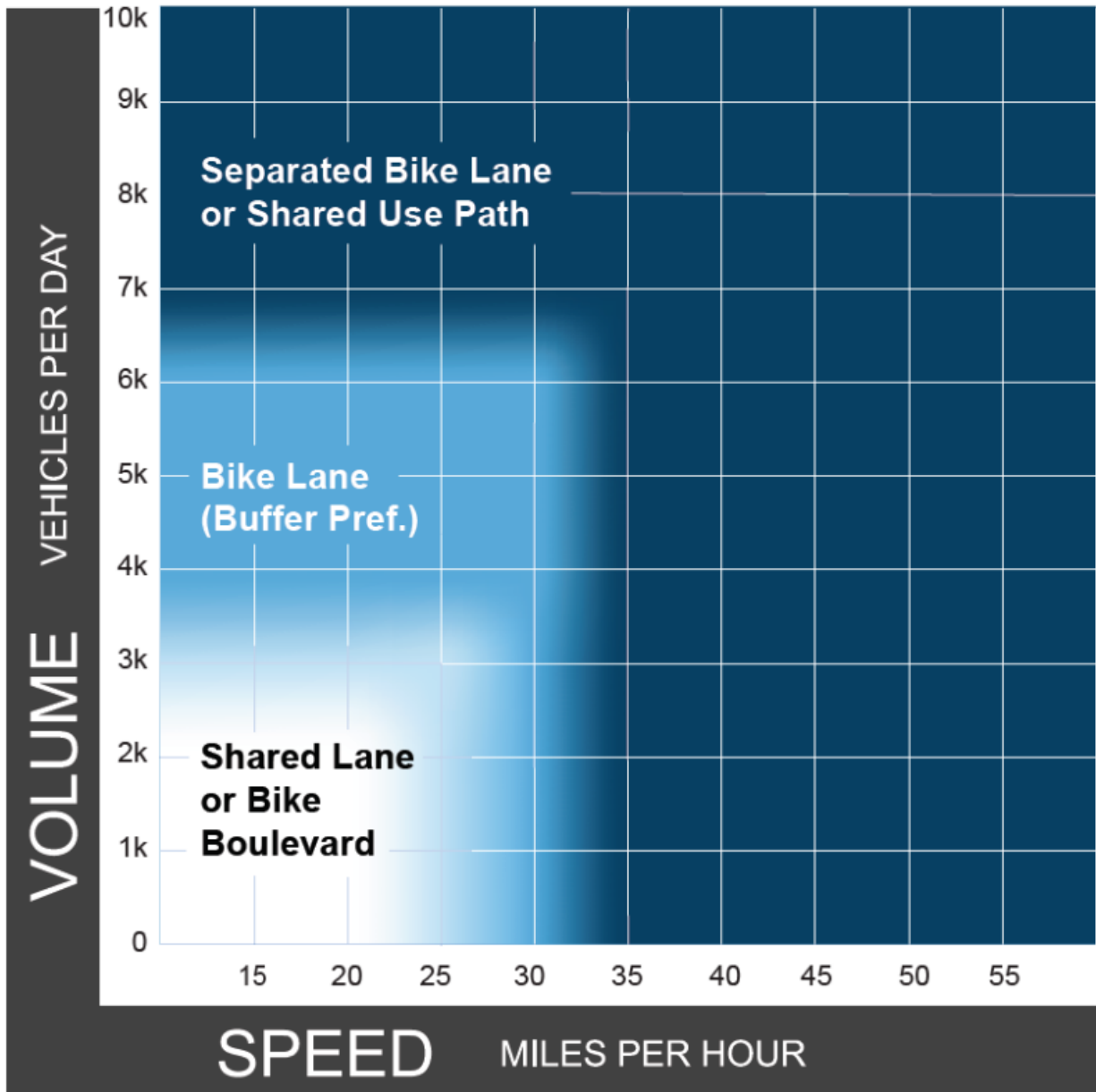

Source: FHWA “Bikeway Selection Guide” (Ref. 11)

Notes:

- Chart assumes operating speeds are similar to posted speeds. If they differ, use operating speed rather than posted speed.
- See Section 1.3.E for a discussion of alternatives if the preferred bikeway type is not feasible.



Figure 2-12. Preferred Bikeway Type for Rural Contexts.

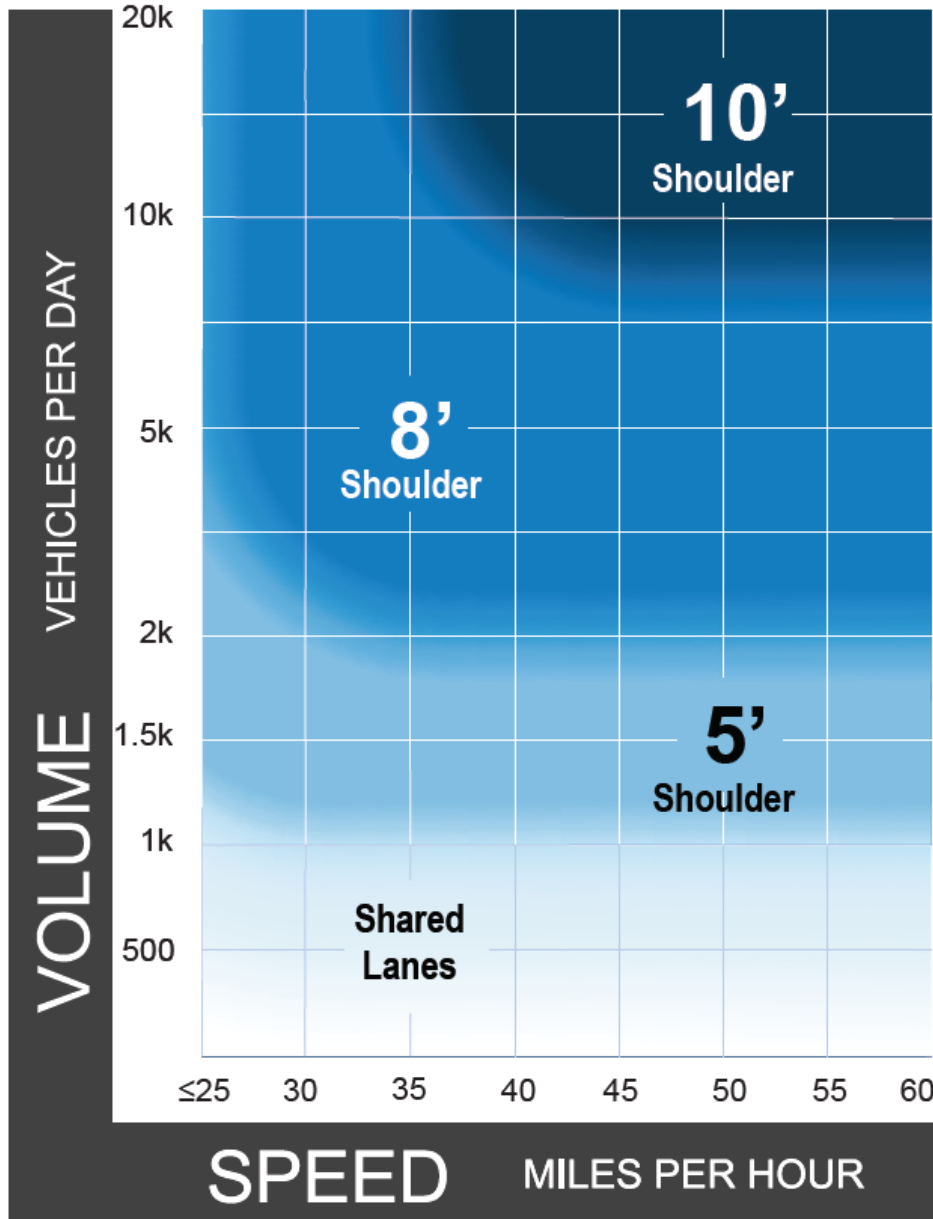

Source: FHWA “Bikeway Selection Guide” (Ref. 11)

Notes:

- This chart assumes the project involves reconstruction or retrofit in constrained conditions. For new construction, follow recommended shoulder widths in the “Green Book” (Ref. 1).
- A separated shared use path is a suitable alternative to providing paved shoulders.
- Chart assumes operating speeds are similar to posted speeds. If they differ, use operating speed rather than posted speed.
- If the percentage of heavy vehicles is greater than 5%, consider providing a wider shoulder or a separated shared use path.

### 3. Transitions Along Bicycle Facilities

As street contexts change, there is often a need to transition between different types of bicycle facilities. Detailed information on elements of bicycle facility design may be found in the FHWA “Bikeway Selection Guide,” the AASHTO “Bike Guide,” and the “Urban Bikeway Design Guide” published by the National Association of City Transportation Officials (NACTO) (Ref. 11, Ref.7, Ref. 12). Some common circumstances are addressed in this section. Intersections, at which other types of bicycle facility transitions may be needed, are discussed in Section 2.4.

Although a continuous network of dedicated bicycle facilities is desirable, before that network is complete there will be circumstances where bike lanes will end and people bicycling must begin sharing the street. In those instances, the BIKES MAY USE FULL LANE sign (R4-11) shall be used (Ref. 10). The SHARE THE ROAD sign is no longer in the MdMUTCD and shall not be used in Howard County. These transitions should be located in areas with good sight distance. The edge of pavement, curb, or edge line should taper at 20:1 so that people bicycling are not forced into a curb or off the pavement. The BIKE LANE sign (R3-17) and ENDS plaque (R3-17bP) shall be used. In the opposite direction, where a bike lane begins, there is less likelihood of conflict. The BIKE LANE sign (R3-17) and AHEAD plaque (R3-17aP) shall be used in these circumstances. Parking in bicycle lanes is a ticketable offense, so bike lanes need to be marked clearly.

Transitions between bike lanes and shared use paths require special attention. This is especially true when one-way bike lanes (separated or not) on both sides of a street must transition to a two-way shared use path on one side of the street. Transitioning people bicycling in a bike lane to a shared use path on the same side of the street may be facilitated by a ramp, as shown in Figure 2-13. People bicycling in the opposite direction need to cross the street to transition from one facility type to the other. This transition should be accomplished at a signalized or STOP-controlled intersection if feasible. Otherwise, a midblock crossing should be considered as specified in Section 2.4.E.

Figure 2-13. Transition between Bike Lane and Shared Use Path.

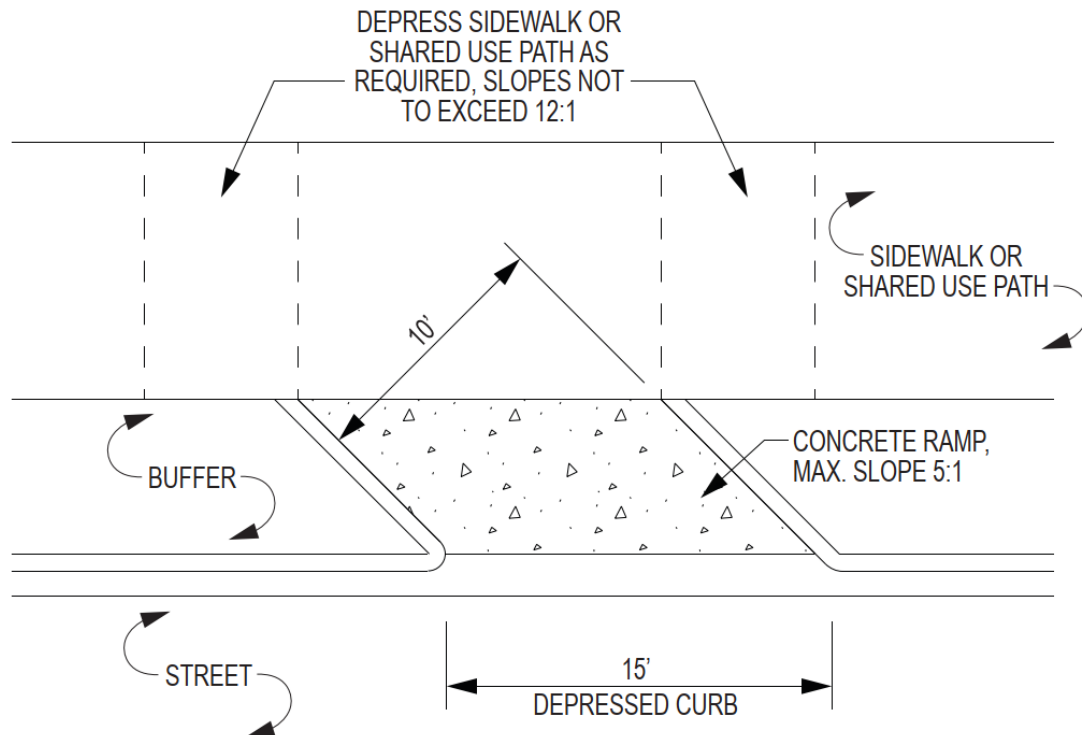

#### 4. Bicycle Facility Pavement Markings

##### a. General pavement markings

Bike lane markings inform all street users of the presence of a bike lane. They shall be provided in the bike lane after each intersection and major commercial driveway, just outside of the wheel path. Additional bike lane markings shall be provided at the beginning of the bike lane and at regular intervals, approximately every 500 feet, so that all street users are aware of the presence of the bike lane. Use MUTCD 9C-3B, "helmeted bicycle symbol" with the arrow as the bike lane marking.

##### b. Conflict zone pavement markings

Guidance on conflict zone pavement markings is provided in Section 2.4.G.3.f. Guidance on pavement markings at driveways is provided in Section 2.5.I.

### E. Travel Lanes

#### 1. Introduction

The design of streets includes the combination of several features to meet the needs of the community with an acceptable level of service and to be economical to construct and maintain with acceptable impacts to the adjacent land. Features include the general layout of the roadway, horizontal geometry, grades, grading, pavement widths, shoulders, walking access, bicycle compatibility, pavement material, drainage facilities, etc.

#### 2. Determination of Typical Section

The typical section shall be determined by Howard County Department of Public Works - Bureau of Engineering based on the street types in Section 1.3.C. These street types should be applied directly for new construction, as well as in retrofit situations where right of way and other constraints allow.

#### 3. Modification of Typical Section or Design Criteria

Each project is unique and may require variability in typical section including lane width, cross-slope, median, sidewalk, shared use paths, bicycle facilities, buffer zones, horizontal and vertical geometry, inclusion of traffic calming devices, etc. In retrofit situations where limited right of way or other constraints make provision of the ideal street type infeasible, Section 1.3.E should be used to identify an appropriate typical section. To incorporate modifications to design standards or modifications to typical sections will require undertaking the Exceptions process described in Section 1.2.F.

#### 4. Right of Way

Right-of-way width is dependent on the street types in Section 1.3.C or it is dependent on functional classification in retrofit projects on existing roadways and shall be as shown on the typical sections.

#### 5. Pavement Widths and Cross Slope

Pavement widths including through lanes, turning lanes, auxiliary lanes shall be as shown on the typical sections. In closed sections, the roadway pavement width shall be measured from flowline to flowline and not to edge of gutter pan nor to back of curb. The Designer must consider the presence of parked vehicles, sight distance, and the presence of people walking and bicycling, especially where no sidewalks or bicycle facilities are provided. The pavement cross slope shall be as shown on the typical sections.

## 6. Paving Section

The Designer or Developer shall obtain the services of a consultant Registered Professional Geotechnical Engineer to prepare a Soils Evaluation and Pavement Design Report. The Geotechnical Engineer shall be licensed to practice in the State of Maryland and shall sign and seal the report. The report shall be submitted to the Department of Public Works and must be approved prior to base paving or as part of the Final Roadway Construction Plans.

The Designer or Developer shall submit, for approval, the Final Road Construction Plans, which specify the street classification, zoning district, and pavement section, as shown in the Typical Sections in the Standard Details Volume IV of the Design Manual. It is preferred that the Soils Evaluation and Pavement Design Report is performed during the design phase of the project and is submitted with the plans. If the soils evaluation and report is to be performed after construction begins, the plans shall include the following note:

“Construction of road base pavement is not permitted until DPW approves the pavement design recommendations submitted in the Soils Evaluation and Pavement Design Report required in Section 504.03, Design Manual Volume IV.”

## 7. Shoulders

Shoulders shall be as shown on the typical sections.

## 8. Medians

Medians shall be as shown on the Standard Details. Raised medians 6 feet or less in width should have a hardscaped surface (concrete, brick, etc.). Unpaved medians shall be seeded and mulched or landscaped with low maintenance vegetation. For special consideration of emergency vehicle movements, mountable medians or mountable median noses may be considered on a case-to-case basis. Special consideration may be made for low-maintenance vegetation for medians narrower than 6 feet based on the context of the area in consultation with the Department of Public Works. For divided streets, future widening shall be planned in the median area.

Medians are often used as refuges for people walking or bicycling across a street. Design guidance for median islands is provided in Sections 2.2.E.10.c.1 and 2.4.E.3.e. Studies to evaluate midblock crossings, including potential medians, are discussed in Section 5.2.C.1.

## 9. Golf Cart Crossing Locations

The crossing locations within the private or public right-of-way for golf cart paths shall be reviewed and approved by the Department of Public Works or Department of Planning and Zoning.

## 10. Speed Management

### a. General

Managing motor vehicle speeds is the most effective way to improve safety, comfort, and convenience for people walking and bicycling on Howard County streets. It has the added benefit of reducing the frequency and severity of motor vehicle crashes. As described in Section 2.1.D.2, new streets should be designed to a target speed that works well for all street users.

The introduction of speed management tools on existing streets should be part of the total street environment. Isolated measures, especially in streets where there is general expectation of higher speeds, can cause crashes.

It is the intent of these standards to design streets that do not encourage speeding. Typical past practices that encouraged long tangent sections of street, long sweeping curves and wide pavement only serve to invite speeding. These standards require the use of short tangent sections, tight curves and narrow pavements to keep speeds at target levels. Certain speed management tools, such as center median islands and curb extensions may be considered as new streets are designed and built. Any of the speed management tools in this section may be used in retrofit situations.

Speed management measures placed at predictable spacing with appropriate signage generally should reduce speeds to the target speed. It is up to the Designer to place a variety of speed management options within the site that best suit the layout and topography of the development. The Designer should use judgement concerning the placement of all speed management measures as not to impede driveway and intersection access, not to conflict with sight distance requirements, and not to introduce a potential unanticipated hazard for motor vehicles and bicyclists. Each Speed Management device used on a street must provide an intuitive route for all types of users relative to the device. For each type of speed management measure used, turning templates must be provided depicting the movements required. It must be shown that the design vehicle can make all turning movements without adversely impacting all users of the street. These templates shall be provided at the preliminary design stage to ensure that the street layout will function adequately.

DPW shall coordinate the installation of any speed management measure with Howard County Department of Fire and Rescue Services.

## b. Speed Management Tools

### 1) Roundabouts and Mini-Roundabouts

Roundabouts and mini-roundabouts slow motorists and serve as traffic control at intersections. They can be incorporated in locations where a traffic signal or stop sign is not warranted. They should also be considered at locations where a signal or stop sign is warranted. Roundabouts generally experience fewer and less serious crashes than signalized intersections. Roundabouts accommodate left turns and reduce the delay and number of stops for all vehicles compared with stop signs or traffic signals. While the initial cost of a roundabout may be higher than other controls, the annual maintenance cost is lower. The planning considerations for determining whether a roundabout is appropriate at a particular location are described in Ref. 14, "NCHRP Report 672, Roundabouts: An Informational Guide," Second Edition, Chapter 3: Planning. Section 2.4.C provides roundabout design guidance.

### 2) Traffic Calming Measures

Traffic calming measures can be classified into categories according to their geometry, horizontal deflection and vertical deflection. Horizontal deflection devices include such things as:

- Raised Center Median Island
- Intersection Curb Extension
- Midblock Street Narrowing
- Chicane
- Mountable Truck Apron

Properly located and designed horizontal deflection devices are highly visible and alert the driver from some distance away to slow down; thus, their placement relative to the roadway's horizontal and vertical curvature must be evaluated. They have less physical effect on traffic and generate less traffic noise than vertical devices. They need to be illuminated for safety.

Vertical deflection devices include:

- Speed Hump/Raised Crosswalk
- Raised Intersection

Vertical deflection devices are not visible from as far away, and therefore are appropriate for use on lower speed streets such as neighborhood streets and neighborhood yield street. They should be used in residential areas, although they may occasionally be appropriate for use in mixed-use areas with a large pedestrian population.

### 3) Lane Narrowing

As with Road Diets, narrowing vehicular lanes can create space to accommodate other modes of travel (see Section 1.3.E. to for applicability in retrofit situations). Research shows that narrower travel lanes can contribute to lower operating speeds and a reduction in crash rates without impacting vehicular capacity (Ref. 15).

The AASHTO “Green Book” allows 10-foot travel lanes in low-speed environments of 45 mph or less (Ref. 1). Section 1.3.C Street Types provides guidance on the default dimensions for new streets and offers a starting point for the design of retrofit projects.

### 4) Road Diet

The term Road Diet refers to reducing the number of travel lanes on an existing street and utilizing the space for other uses or modes of travel, such as on-road bike lanes and medians to support safer pedestrian crossings (see Section 1.3.E for applicability in retrofit situations). Road Diets also have a traffic calming effect, which creates a more comfortable environment for all road users. In addition to slowing operating speeds, Road Diets also reduce the speed differential that exists on a multi-lane road.

The most common Road Diet configuration is the conversion of a four-lane undivided roadway to a three-lane roadway featuring a center two-way left-turn lane. However, it should be noted that wider roadways, including six lane roadway reductions to four or two lanes, have also been successfully converted into complete streets in other jurisdictions. The provision of the center turn lane reduces rear-end and left turn crashes. Because motorists have fewer lanes of traffic to cross there are fewer conflict points resulting in a reduction in right-angle crashes as shown in Figure 2-14.

Additional guidance for assessing Road Diet feasibility, design, and effectiveness is available in the FHWA “Road Diet Informational Guide” (Ref. 16).

Figure 2-14. Typical Road Diet basic design.

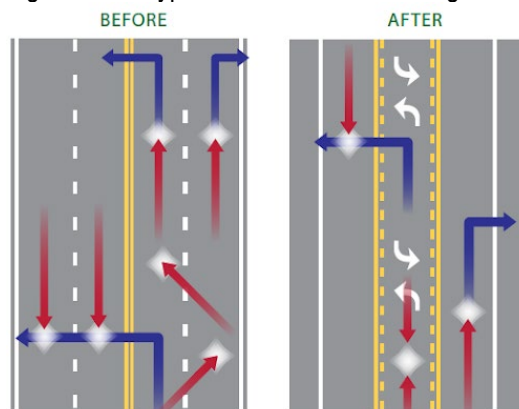

Source: FHWA “Road Diet Informational Guide” (Ref. 16)



c. Traffic Calming Measures Definitions and Design Characteristics

Each type of measure has different engineering design criteria which helps to determine when it is appropriate. The Designer needs to be aware that the type and placement of speed management devices will have a significant impact on the visual character of both the streetscape and subdivision layout. Some combinations will create a more formal streetscape that is generally appropriate for higher density developments. Other combinations will appear more informal and be suitable for rural and low-density developments.

1) Raised Center Median Island

Raised center median islands narrow travel lanes and can serve as a refuge for people walking or bicycling across the street. Islands can effectively control speeds when placed either midblock or at intersections to reduce the speeds of turning movements. When used as a pedestrian refuge, a protective nose should be provided so that turning vehicles do not turn over the area where pedestrians stand.

**TABLE 2-6  
APPROPRIATE APPLICATION OF A RAISED CENTER MEDIAN ISLAND**

<b>Type of Street</b>	Appropriate for an arterial, collector, or local street Appropriate for a mixed-use or suburban setting Appropriate for a residential or commercial setting For appropriate Street Types, see Table 2-12
<b>Intersection or Roadway Segment</b>	Can be placed at midblock location or on the approach to an intersection If placed through an intersection, a median island is considered a median barrier When placed on a curve, can be effective reducing or retaining low vehicle speeds May be effective when placed immediately downstream of an intersection; island forces motorist to turn in accordance with curb radius (i.e., and not swing wide at a higher speed)
<b>Roadway Cross-Section</b>	Appropriate only on a two-way street; number of lanes in each direction can be one or more Typically installed only on a roadway with curb and gutter
<b>Speed Limit</b>	Can be appropriate for any speed limit on Howard County maintained streets with appropriate lateral clearance provided between the travel lane and the median island curb
<b>Motor Vehicle Traffic Volume</b>	Can be appropriate at all levels of traffic volume
<b>Emergency Route</b>	Can be appropriate along a primary emergency vehicle route or street that provides access to a hospital or emergency medical services if adequate turning radii can be provided
<b>Transit Route</b>	Can be appropriate along a bus transit route if appropriate turning radii can be provided
<b>Access Route</b>	Typically not appropriate along a primary access route to an industrial site; a roadway cross-section designed to accommodate large combination vehicles at a median island will result in a travel lane that is too wide to have an effect on passenger vehicle speeds
<b>Grade</b>	Can be installed on a crest vertical curve only if there is adequate stopping sight distance or if appropriate warning signs are provided. Raised median islands should be carefully considered on roadways with a grade of 6 percent or greater.

Source: Modified from FHWA "Traffic Calming e-Primer" (Ref. 17)

A variety of median widths may be considered:

- 4 feet: not preferred, but allowable in constrained situations
- 6 feet: minimum for the median to serve as a refuge
- 8 feet: preferred to serve as refuge and/or for planting of street trees
- 10 feet: preferred for trail crossings or bicycles with trailers

A minimum width of 12 feet shall be provided for each direction of travel on each side of the median, measured from curb face to curb face. When islands are located at or near intersections, evaluate the movements of design and control vehicles as described in Section 2.1.D.3. Where bicycle facilities are provided on the street, consideration should be given to rerouting the bike lane outside the curb rather than requiring people to bicycle in the travel lane. See Volume IV for details.

Figure 2-15. Raised Center Median Island.



Source: Howard County

## 2) Intersection Curb Extension

Intersection curb extensions, also known as bulb-outs or bump-outs, extend the curb into the street at the corner of intersections. They are generally used where on-street parking is provided. At intersections, curb extensions reduce crosswalk lengths, improve sight distance among all users of the street, and reduce the effective radius of the corner, helping to reduce motor vehicle speeds. Curb extensions may include crosswalks or stormwater management facilities such as rain gardens, or even landscaping in areas where it will not obstruct sight distance.

**TABLE 2-7**  
**APPROPRIATE APPLICATION OF AN INTERSECTION CURB EXTENSION**

<b>Type of Street</b>	Appropriate for a minor collector or local street Appropriate for a mixed-use or suburban setting Appropriate for a residential setting For appropriate Street Types, see Table 2-12
<b>Intersection or Roadway Segment</b>	Applicable at an intersection (bulb-out) Can be applied on any or all of the approach legs of an intersection with any number of legs
<b>Roadway Cross-Section</b>	Can be used on both one-way and two-way streets Can be installed only on a roadway with curb and gutter Can be applied both with and without a bicycle facility Can be applied on a roadway with, and can protect, on-street parking
<b>Speed Limit</b>	Can be appropriate for Howard County maintained streets with up to a 35 mph posted speed limit, with appropriate lateral distance between the travel lane and the intersection extension curb
<b>Motor Vehicle Traffic Volume</b>	Can be appropriate at all levels of traffic volume typical of a collector or local street
<b>Emergency Route</b>	Can be appropriate along a primary emergency vehicle route or street that provides access to a hospital or emergency medical services if appropriate turning radii can be provided
<b>Transit Route</b>	May not be appropriate at intersections where a bus turns along a transit route if an adequate turning radius cannot be provided; the number of turning transit vehicles and the total motor vehicle traffic volume on the receiving street are both factors when a corner extension is considered A corner extension bus stop eliminates the need to remove on-street parking that would enable a transit vehicle to maneuver to and from the traditional curb An extended length curb extension could enable a bus stop landing area for both front and back transit bus doors, thereby eliminating the need for a bus to pull out of (and pull back into) traffic
<b>Access Route</b>	Typically not appropriate along a primary access route to a commercial or industrial site if an adequate turning radius cannot be provided The number of large turning vehicles and the total motor vehicle traffic volume on the receiving street are both factors when a corner extension is considered
<b>Grade</b>	Can be installed on a crest vertical curve only if there is adequate stopping sight distance or if appropriate warning signs are provided Intersection curb extensions should be carefully considered on roadways with a grade of 6 percent or greater.

Source: Modified from FHWA "Traffic Calming e-Primer" (Ref. 17)

Curb extensions should typically be provided with a 1'-6" offset to travel lane or such that the edge of gutter is coincident with the edge of a bicycle lane. The curb extension must be designed to accommodate the drainage patterns of the site. Where bicycle facilities are provided on the street but cannot be accommodated by the curb extension, consideration should be given to rerouting the bike lane outside the curb through a bicycle transition to the shared use facility (See Section 2.2.D.3) rather than requiring people to bicycle in the travel lane. See Volume IV for details.

Figure 2-16. Intersection Curb Extension provided as a retrofit.



Source: Howard County.

## 3) Midblock Street Narrowing

Midblock Street Narrowing, also known as chokers, neckdowns, or pinch points, refers to narrowing the roadway section to slow motor vehicles. Street narrowing can be achieved through the use of two curb extensions or roadside islands placed at a midblock location. A two-lane treatment narrows the curb to curb width of the roadway while still allowing vehicles to pass each other without conflict. Where motor vehicle volumes are low, curb extensions or islands can be used to reduce the street width to less than two lanes. This one-lane treatment requires people driving to yield to each other and take turns to pass through the pinch point, further reducing speeds.

Street narrowing can be installed at any spacing. Stormwater management facilities, such as rain gardens or landscaping, can be accommodated in areas where it will not obstruct sight distance. Movements of design and control vehicles must be considered. See Volume IV for details.

**TABLE 2-8**  
**APPROPRIATE APPLICATION OF MIDBLOCK STREET NARROWING**

<b>Type of Street</b>	Appropriate for a local street Appropriate for a mixed-use or suburban setting Appropriate for a residential or commercial setting For appropriate Street Types, see Table 2-12
<b>Intersection or Roadway Segment</b>	Applicable midblock
<b>Roadway Cross-Section</b>	Can be used on both one-lane, one-way and two-lane, two-way streets More easily installed on a roadway with curb and gutter Can be applied both with and without a bicycle facility Can be applied on a roadway with, and can protect, on-street parking
<b>Speed Limit</b>	Can be appropriate for 25 MPH speed limit, provided an adequate shy distance is provided between the travel lane and the curb extension curb
<b>Motor Vehicle Traffic Volume</b>	Can be appropriate for traffic volumes typical of a minor collector street or less
<b>Emergency Route</b>	Can be appropriate along a primary emergency vehicle route or street that provides access to a hospital or emergency medical services
<b>Transit Route</b>	Not appropriate along a bus transit route
<b>Access Route</b>	Not appropriate along a primary access route to a commercial or industrial site
<b>Grade</b>	Can be installed on a crest vertical curve only if there is adequate stopping sight distance or if appropriate warning signs are provided Midblock street narrowing should be carefully considered on streets with a grade of 6 percent or greater.

Source: Modified from FHWA "Traffic Calming e-Primer" (Ref. 17)



Where bicycle facilities are provided on the street but cannot be accommodated at the midblock street narrowing, consideration should be given to rerouting the bike lane outside the curb through a bicycle transition to a shared use facility (See Section 2.2.D.3) rather than requiring people to bicycle in the travel lane. This requirement does not apply on Neighborhood Yield Streets or Rural Residential Streets.

Figure 2-17. Midblock Street Narrowing.



Source: Howard County

## 4) Chicane

Chicanes consist of curb extensions or other physical elements placed on alternating sides of a street to create a series of curves in the travel path. They are placed in midblock locations to reduce motor vehicle speeds. On two-way streets, street narrowing is often implemented along with chicanes so that people don't just drive across the centerline to maintain their speed. Alternatively, a raised median could be used along with the chicane to create a lateral shift. Where trucks must be accommodated, this measure may be combined with truck aprons as noted later in this section.

**TABLE 2-9  
APPROPRIATE APPLICATION OF A CHICANE**

<b>Type of Street</b>	Appropriate for a low-volume collector or local street Appropriate for a mixed-use or suburban setting Appropriate for a residential or commercial setting For appropriate Street Types, see Table 2-12
<b>Intersection or Roadway Segment</b>	Applicable midblock or the entire block if the block length is short
<b>Roadway Cross-Section</b>	Can be used on a one-lane, one-way and two-lane, two-way road Can be installed with either an open section or a roadway with curb and gutter Can be applied both with and without a bicycle facility Can be combined with a raised center median island (see note on emergency access)
<b>Speed Limit</b>	Can be appropriate if the speed limit is 25 MPH.
<b>Motor Vehicle Traffic Volume</b>	Can be appropriate if motor vehicle traffic volume is less than 3,500 vehicles per day Most effective in reducing speeds if traffic volumes are relatively balanced in each direction
<b>Emergency Route</b>	Can be appropriate along a primary emergency vehicle route or on a street that provides access to hospital/emergency medical services, provided motor vehicle traffic volumes are low enough to allow an emergency vehicle to straddle the street centerline
<b>Transit Route</b>	Can be appropriate along a bus transit route
<b>Access Route</b>	Not typically appropriate along a primary access route to a commercial or industrial site
<b>Grade</b>	Can be installed on a crest vertical curve only if there is adequate stopping sight distance or warning signs are provided Chicanes are not appropriate for streets with a 6 percent grade or greater.

Source: Modified from FHWA "Traffic Calming ePrimer" (Ref. 17)

Chicanes may be spaced as follows:

<u>Speed (mph)</u>	<u>Spacing (ft)</u>
20	500
25	600

This spacing criteria is restarted from each stop controlled intersection.

Where bicycle facilities are provided on the street but cannot be accommodated at the chicane, consideration should be given to rerouting the bike lane outside the curb through a bicycle transition to the shared use facility (See Section 2.2.D.3) rather than requiring people to bicycle in the travel lane.

Figure 2-18. Typical two-way Chicane.

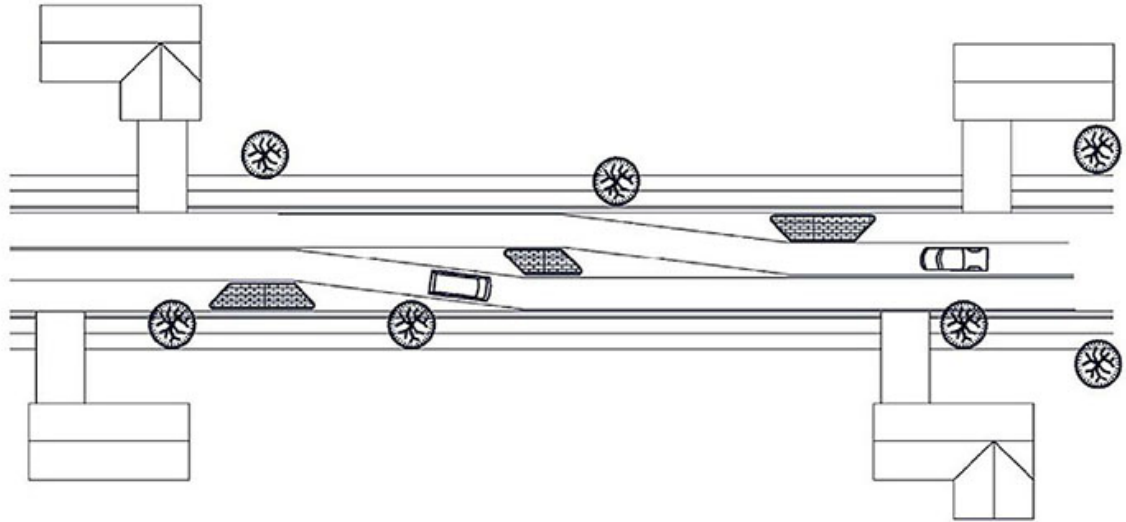

Source: "Delaware Traffic Calming Design Manual," 2012 (Ref. 18)

Figure 2-19. Chicane.



Source: Howard County



## 5) Mountable Truck Apron

Mountable truck aprons are slightly raised areas that are designed to be used only by larger vehicles. They are typically concrete and raised two inches above the adjacent pavement with a 45-degree bevel. This configuration makes it uncomfortable for the drivers of passenger cars to traverse, but trucks can negotiate these aprons easily. Truck aprons reduce the effective width of the street or intersection, reducing speeds but still allowing larger vehicles to track outside the pavement.

Truck aprons shall be designed to minimize the likelihood that people walking or bicycling across the street will wait in this area rather than behind the curb.

Truck aprons should be considered when designing roundabouts, curb extensions/street narrowing, and traffic islands. If a curb ramp and crosswalk is present, the truck apron should be placed between the intersection and the ramp, or after the crosswalk, as to not encourage larger vehicles to mount the curb in a location where pedestrians may be standing. See Volume IV for details.

Figure 2-20. Mountable Truck Apron.



Source: Howard County

## 6) Speed Hump/Raised Crosswalk

A speed hump is a raised section of pavement that extends across most of the street perpendicular to the flow of traffic. It has a wide, flat top that allows people to comfortably drive across at or below posted speeds but creates discomfort at excessive speeds. If a crosswalk is installed across the top of the speed hump, it is known as a raised crosswalk. Speed humps and raised crosswalks should only be used midblock. See Volume IV for details.

Speed humps are not preferred on new construction roadways, but can be provided in retrofit situations.

**TABLE 2-10**  
**APPROPRIATE APPLICATION OF A SPEED HUMP/RAISED CROSSWALK**

<b>Type of Street</b>	Appropriate for collector and local streets Appropriate for a suburban setting Appropriate for a residential setting For appropriate Street Types, see Table 2-12
<b>Intersection or Roadway Segment</b>	Placed at a midblock location; a minimum 200 distance from an intersection Should not be placed on a sharp curve; <i>ITE Guidelines for the Design and Application of Speed Humps</i> recommends a minimum horizontal curve radius of 300 feet
<b>Roadway Cross-Section</b>	Can be used on a single-lane one-way or two-lane two-way street (see Figure 3.12.2) Typically installed on a street with curb and gutter but an open section can be acceptable Can be applied both with and without sidewalks or bicycle facilities. When bicycle facilities are on-road, a gap in the speed hump should be considered
<b>Speed Limit</b>	Consideration of humps are only on a minor collector street with residential frontage and a posted speed limit of 30 mph or less, and local residential streets with a posted speed limit of 25 MPH. Speed humps are not appropriate when the pre-implementation 85th percentile speed is 45 mph or more
<b>Motor Vehicle Traffic Volume</b>	Can be appropriate if minimum average motor vehicle traffic volume is 1,200 and maximum daily volume of 4,000. <i>ITE Guidelines for the Design and Application of Speed Humps</i> recommends consideration if no more than five percent of the overall traffic flow consists of long-wheelbase vehicles
<b>Emergency Route</b>	Generally not appropriate for a primary emergency vehicle route or street that provides access to a hospital or emergency medical services
<b>Transit Route</b>	Generally not appropriate for a bus transit route with BRT, Express, or Limited Stop service (unless the posted speed limit is 30 mph or less) Can be appropriate along a neighborhood circulator or other local bus service route Should not be located near bus stop to ensure passengers are not transitioning between standing and sitting as the bus crosses over the speed hump
<b>Access Route</b>	Not appropriate along the primary access to a commercial or industrial site
<b>Grade</b>	Can be installed on, or beyond, a crest vertical curve only if there is adequate stopping sight distance or warning signs are provided Can be installed on streets with less than or equal to 6 percent grade

Source: Modified from FHWA "Traffic Calming Primer" (Ref. 17)

To reduce the likelihood of people driving too quickly between speed humps, the following spacing is recommended:

Speed (mph)	Spacing (feet)
20	500
25	600

Speed humps should be placed no closer than 200 feet to an intersection. They should not be placed on streets less than 1200 feet in length or on dead-end streets. They should not be installed on streets with severe grades or on relatively sharp horizontal curves.

A small gap should be provided between the end of the speed hump and the adjacent curb such that the speed hump does not extend into the gutter pan to accommodate drainage. Adequate pavement markings and signing should be installed to alert drivers when approaching speed humps. A traffic analysis shall be submitted to the Department of Public Works addressing impacts from installing speed humps. Speed humps in neighborhoods require a vote from residents, as described in the Traffic Calming Policy for Primary and Secondary Residential Streets. It should be noted that The Department of Public Works reserves the right to install other speed management measures to address documented significant safety problems directly attributed to excessive speeds, even if citizen support is not received.

Figure 2-21. Speed Hump.



Source: Howard County



## 7) Raised Intersection

Raised intersections encompass an entire intersection. This allows one measure to control speeds on both intersecting streets. Their elongated design means that speed reduction is more modest than speed humps. See Volume IV for details.

**TABLE 2-11**  
**APPROPRIATE APPLICATION OF A RAISED INTERSECTION**

<b>Type of Street</b>	Appropriate if there are existing crosswalks on all four legs of the intersection or if crosswalks are warranted Appropriate for the intersection of collector, local, and residential subdivision streets Could be appropriate for the intersection of low-speed arterial in a downtown commercial business district with significant pedestrian activity For appropriate Street Types, see Table 2-12
<b>Intersection or Roadway Segment</b>	Placed at an intersection Can be a T-intersection or multi-leg intersection
<b>Roadway Cross-Section</b>	Approach legs can be either one-way or two-way Appropriate only on a roadway with curb and gutter that includes sidewalks on all sides of the intersection Can include on-site parking on the approach legs Appropriate if a bicycle facility passes through the intersection
<b>Speed Limit</b>	Maximum speed limit of 30 mph based on ITE Guidelines for the Design and Application of Speed Humps and some jurisdictions (e.g., South Carolina, Pennsylvania); others use a 35 mph maximum (e.g., Delaware)
<b>Motor Vehicle Traffic Volume</b>	Appropriate if the maximum daily motor vehicle traffic volume is 5,000 vehicles per day
<b>Emergency Route</b>	Can be an appropriate application for a primary emergency vehicle route or on street that provides access to a hospital or emergency medical services
<b>Transit Route</b>	Can be an appropriate application for a bus transit route
<b>Access Route</b>	Generally not appropriate along the primary access to a commercial or industrial site
<b>Grade</b>	Can be installed on a crest vertical curve only if there is adequate stopping sight distance or if appropriate warning signs are provided Maximum grade of 6 percent

Source: Modified from FHWA "Traffic Calming ePrimer" (Ref. 17)

Figure 2-22. Raised Intersection.



Source: NACTO

d. Appropriate Speed Management Treatment for Street Types and Retrofits

**TABLE 2-12**  
**APPROPRIATE SPEED MANAGEMENT TREATMENT FOR NEW STREETS MATRIX**

Category	Measure	Street Types (New Construction)												Page Reference
		Boulevard	Town Center Connector	Town Center Street	Parkway	Neighborhood Connector	Neighborhood Street 1	Neighborhood Street 2	Neighborhood Yield Street	Alley	Industrial Street	Country Street	Rural Development Street	
<b>Road Narrowing</b>	Road Diet	O	X	X	O	X	X	X	X	X	X	X	X	
	Lane Diet	See default Street Type dimensions in Section 1.3.C												1-11
<b>Vertical Measures</b>	Speed Hump	X	X	X	X	X	O	O	O	X	X	X	O	
	Raised Crosswalk	X	X	X	X	X	O	O	O	X	X	X	O	
	Raised Intersection	X	X	X	X	O	O	O	O	X	X	X	X	
<b>Horizontal Measures</b>	Raised Center Median Island	O	O	O	X	O	O	O	O	X	X	X	X	
	Intersection Curb Extension	O	O	O	X	O	O	O	O	X	X	X	X	
	One-Lane Midblock Street Narrowing	X	X	X	X	X	X	X	O	X	X	X	X	
	Two-Lane Midblock Street Narrowing	X	X	O	X	O	O	O	X	X	X	X	X	
	Chicane	X	X	X	X	X	O	O	O	X	X	X	X	
	On-Street Parking	O	O	O	X	O	O	O	R	X	R	X	O	
	Mountable Truck Apron	X	O	O	X	O	O	O	O	X	O	X	X	
	Mini Roundabout	See Section 2.4.C												
<b>R</b> Recommended (Context-Sensitive)														
<b>O</b> Optional (Context-Sensitive)														
<b>X</b> Not Permitted or N/A														

**TABLE 2-13  
APPROPRIATE SPEED MANAGEMENT TECHNIQUES FOR RETROFITS**

Category	Measure	Functional Classification				
		Intermediate Arterial	Minor Arterial	Major Collector	Minor Collector	Local Road
<b>Road Narrowing</b>	Road Diet	O	O	O	O	O
	Lane Diet	O	O	O	O	O
<b>Vertical Measures</b>	Speed Hump	X	X	O	O	O
	Raised Crosswalk	X	X	O	O	O
	Raised Intersection	X	X	O	O	O
<b>Horizontal Measures</b>	Raised Center Median Island	O	O	O	O	O
	Intersection Curb Extension	X	X	O	O	O
	One-Lane Midblock Street Narrowing	X	X	X	X	O
	Two-Lane Midblock Street Narrowing	X	X	X	O	O
	Chicane	X	X	X	O	O
	On-Street Parking	X	O	O	O	O
	Mountable Truck Apron	O	O	O	O	O
	Mini Roundabout	See Section 2.4.C				
<b>R</b> Recommended (Context-Sensitive) <b>O</b> Optional (Context-Sensitive) <b>X</b> Not Permitted or N/A						

## F. Street Trees

Street trees provide great value for people walking and bicycling. They offer shade in hot weather and can provide a modest traffic calming effect. Street trees are provided in all street types in Section 1.3.C. See the “Howard County Landscape Manual” for specific requirements (Ref. 19).

## G. Minimum Edge Distance to Any Roadside Appurtenance

For sheet aluminum roadway signs, the distance from face of curb to edge of sign shall not be less than 2-feet. In open sections, the distance from edge of shoulder to edge of a sign shall not be less than 6-feet.

For all other objects, the distance from the face of curb or edge of shoulder to any roadside appurtenance shall not be less than 3-feet. Vertical elements such as tubular markers which are used to assist in delineating separation of a separated bike lane are exempt from this requirement as they are designed to yield if struck accidentally.

For offsets from shared use paths to vertical obstructions, see Section 2.2.C.2.

## H. Accommodation of Utilities in Typical Sections

The normal locations for the placement of utilities within the right-of-way are shown in the Standard Details of Volume IV of the Design Manual. Where conditions are such that the use of the normal location arrangements would be infeasible or for scenic roads, would have an adverse impact on scenic features such as roadside vegetation, embankments, wetlands and streams, an alternate arrangement shall be developed and submitted to the Department of Public Works for review and approval. All utility owners shall have their utility installation plans approved before any construction is initiated in accordance with the agreement executed between the County and utility company.

Requirements for telephone, gas, electric and cable television submittals:

1. All drawings must be accompanied by a transmittal letter that includes the following information:
  - a. Name of Development
  - b. Location
  - c. Election District
  - d. Project Number
  - e. Water and Sewer Contract Numbers
  - f. Type of Construction
  - g. Alexandria Drafting Company (ADC) Map Number and Grid
2. All existing and proposed sewer lines, water lines, house connections, fire hydrants, storm drains, manholes, stormwater management facilities, related appurtenances and sidewalks must be shown on all drawings submitted for approval.
3. All existing and proposed water and sewer lines must be identified by contract number.
4. The diameter of all water lines, sewer lines and storm drains must be shown.
5. All existing utility poles must be shown and pole numbers must be labeled.
6. All plans submitted must be to scale, using a minimum scale of 1" = 50'.

7. The following information is to be noted on all drawings:
  - a. "Maintain a 5-foot horizontal clearance and a 1-foot vertical clearance from all existing and proposed water lines, sewer lines, fire hydrants, storm drains and related appurtenances when installing cable, transformer pedestals, gas lines, utility poles, and guide wires."
  - b. "Any pedestal placed in conflict with sidewalk or county owned/maintained utility will be moved at the company's expense."
  - c. Indicated at all fire hydrants "Do Not Disturb Buttress".
8. Transformers and/or pedestals should be located on property lines without twin water/sewer house connections. In those areas where a transformer and/or pedestal is required at a property line adjacent to a water or sewer house connection, the unit shall be set back six to ten feet from the front of the property line. The drawing shall clearly indicate the potential conflict and a note referencing the setback shall be provided.
9. Transformers and/or pedestals shall not be placed in storm water management access easements.
10. Transformers, pedestals or other box-like equipment should not be visible from scenic roads. Use depressions, berms, or vegetation to screen.
11. Utilities, including transformers, pedestals, and other box-like equipment, shall not adversely impact sight distance of any type, including intersection sight distance and horizontal stopping sight distance on the inside of a curve. Refer to Section 2.1.E for sight distance criteria.
12. The location of all street trees shall be shown on all drawings. Trees damaged or destroyed will be replaced at the utility company's expense. Any tree removal within the public right of way must be done under a Maryland Department of Natural Resources street tree permit.
13. An application for a utility permit must be submitted concurrent with the design submission
14. Design must strive to locate handboxes, manhole covers, meter valves, access points to underground vaults, etc. outside of the sidewalk.

#### **I. Accommodation of Stormwater Management in Typical Sections**

Stormwater management may be accommodated in the Right of Way with approval from the Department of Public Works. Drainage and stormwater management are addressed in detail in Design Manual Volume I.



## 2.3 Geometric Design

### A. Horizontal Alignment

#### 1. Horizontal Curves

Horizontal curves are used to change direction at a safe rate and shall be used whenever the roadway centerline changes direction.

The relationship of the design speed, curvature and superelevation, which must be established to provide a balanced design, is developed in this section. Also, see Appendix A for Roadway Design Criteria on retrofit projects.

Reverse curves and compound curves are combinations of simple curves, and criteria governing their use are included in the following section.

#### a. Design Speed/Minimum Radii

For existing roadways, the design speed and minimum radii of horizontal curves for a selected roadway classification, shall be limited as shown in Appendix A. For proposed streets, the minimum curve radius shall conform to the values in the 2018 *Green Book*, Table 3-13, Minimum Radii and Superelevation for Low-Speed Streets in Urban Areas. Assuming a -3.0% slope as provided in the Volume IV typical sections, the radius at the inner edge of the lane which slopes in the opposite direction of the curve shall be provided as per Table 2-14

**TABLE 2-14**  
**MINIMUM RADIUS USING -3.0% CROSS SLOPE**

Design Speed (mph)	Minimum Inner Edge Radius (ft)
15	52
20	111
25	208
30	353
35	544
40	821
45	1125

#### b. Curve Data

A simple circular curve is a circular arc joining two tangents. A typical curve, along with the pertinent definitions and the formulas needed to calculate the various parts of the curve is shown in Appendix B, Horizontal Circular Curve and are based on the arc definition of a circular curve.

#### c. Minimum Curve Length

The minimum length of horizontal curves, not used for speed control, shall be 100' on Neighborhood Yield Streets, Alleys, Industrial Streets, and Rural Development Streets; 150' on Neighborhood Street 1, Neighborhood Street 2, Town Connector Streets, and Town Center Streets, 300' on Boulevards, Neighborhood Connectors, and Country Streets, and 500' on Parkways. In no case shall the length of curve be less than the minimum superelevation runoff, where superelevation is applied.

## d. Reverse Curve

Where reverse curves are used, an abrupt reversal in alignment shall be avoided and length of tangent sufficient for superelevation runoff, but in no case less than 100 feet, shall be provided between the curves, except on Neighborhood Yield Streets.

## e. Compound Curves

In compound circular curves, the radius of the flatter curve should not be more than 1.5 times greater than the radius of the sharper curve.

## f. Horizontal Sight Distance

Another control on horizontal alignment is the sight distance across the inside of curves. Where there are sight obstructions such as buildings, trees, hedges, walls, traffic barrier, utility boxes, monument signs, berms, or cut slopes, efforts shall be made to provide as long sight distance as feasible, but never less than the stopping sight distance.

The relationship between horizontal curvature, distance to obstruction, and sight distance for those cases in which the curve is longer than the pertinent sight distance can be found in the "Green Book," Figure 3-23, *Diagram Illustrating Components for Determining Horizontal Sight Distance* (Ref. 1). Where this exhibit will not apply, a check for sight distance should be made by scaling dimensions on the plans and profiles.

A height of 2.0 feet above the pavement shall be used as the height of cut slope at which sight is obstructed. This height shall be either the height of the cut slope itself, or, where there is expected to be vegetative cover, the height of such cover (normally 1 foot).

Where there are no sight obstructions within the right-of-way, the right-of-way line shall be used as the sight obstruction or alternately by the inclusion of an easement on a record plat to maintain a clear line of sight zone.

More information on sight distance requirements is provide in Section 2.1.E.

## g. General Controls of Horizontal Alignment

In addition to the specific criteria presented in previous sections, the following general controls shall be utilized:

- 1) Geometry shall be selected to encourage compliance with the target speed where possible.
- 2) In selecting the alignment for a given design speed, use of the maximum curvature for that speed should be avoided.
- 3) Consideration shall be given to the alignment and its effect on operating speed. The speed at the bottom of a long downgrade, for example, will be higher than on a level grade, and this shall be considered when introducing a horizontal curve.
- 4) Sharp curvature should not be used at the ends of a long tangent. A series of curves should be used to introduce a sharp curvature or speed management measures should be used to encourage appropriate operating speeds approaching the curve.
- 5) Sharp curvature shall be avoided on long, high fills. The absence of reference items such as slopes, trees and buildings makes it difficult for the driver to judge horizontal curvature.
- 6) Broken back curves, that is, two curves in the same direction separated by a short tangent, should be avoided. Such an arrangement can usually be replaced by a series of compound curves or a single larger radius curve.

## 2. Intersection Geometry

Intersection design criteria are discussed in Section 2.4.

## 3. Special Design Elements

If the Department of Public Works requires or the Designer requests to incorporate any of the following features, the following criteria shall be met:

### a. Roundabouts

A roundabout is an unsignalized intersection with a center island with traffic circulating in counter clockwise direction. Traffic entering the roundabout must yield to circulating traffic. Roundabout Design criteria is discussed in Section 2.4.C.

### b. Monumental Entrances

Monumental entrances are divided streets constructed at a community main entrance. The median width shall be a minimum 8 feet wide, the entrance lane width shall be a minimum 18 feet wide and the exit lane width shall be a minimum 18 feet wide unless the motor vehicle traffic analysis requires a two lane exit in which the minimum width shall be 24 feet wide. The radii of the curb return shall conform to criteria for analysis set forth in the Section 2.4.B.4 (Intersection Design).

The length of the entrance shall be a minimum of 100 feet long and transition back to the standard street width with a transition rate of 15:1.

Monumental entrances that feature gateway signing, plantings, etc. shall not block sight distance.

### c. Divided Roadways

Generally, divided roadways may be constructed for the Boulevard and Parkway street types. Desirable median widths are shown in Section 1.3.C. A wide median may be planted except plantings shall not reduce intersection sight distance. The plantings shall be located outside the clear zone.

### d. Grade Separated Interchanges

Although any of several factors may warrant the construction of a grade separated interchange, the most common warrants are high motor vehicle traffic volumes and safety considerations. When an intersection level of service analysis indicates a low level of service or the need for more lanes than can be feasibly provided, a grade separated interchange may be considered.

Interchange design criteria can be found in the "Green Book" (Ref. 1). In addition, interchange ramps shall conform to the criteria set forth for turning roadways in Section 2.4.B.6. Limiting values of grades are given in Section 2.3.B.1.

The design procedure for interchanges is similar to that for major intersections. The development of alternatives and the selection of the optimum plan proceed in a similar fashion. More careful attention, however, must be paid to profiles for interchanges than for at-grade intersections, even when preparing study sketches.

The intersection of interchange ramps with the crossroad should be designed as any at-grade intersection, including provision of adequate sight distance and storage and crossings for people walking and bicycling. Special consideration should be given to bridge piers, abutments, and railings which can restrict sight distance if not properly located, and to the high speed of vehicles on exit ramps which might result in crashes at the terminal with the crossroad if the ramp is not properly designed. As with at-grade intersections that are not associated with interchanges, ramp terminal intersections shall be designed to safely and efficiently accommodate all modes of travel, including walking and bicycling. As described in Section 2.4, intersections shall be designed to encourage slow speeds for turning motor vehicles to minimize conflicts. If high-speed turning movements must be provided through ramps, crossings for people walking and bicycling should be grade separated in accordance with Sections 3.6 and 3.7.

e. Permanent Non-Through Streets

Permanent non-through streets consists of residential and non-residential streets that are permanently designed with only one end open to motor vehicle traffic. Permanent non-through streets shall be terminated with a cul-de-sac turnaround with a minimum radius of the paved circular portion of 45' in a minimum 55' right of way in residential areas and 47' in a minimum 60' right of way in non-residential areas. The width of right of way at a cul-de-sac shall not be less than right of way width of the street which terminates within it. The maximum length of a non-through street is 1,200 feet, measured from the flow line of the nearest public street intersection to the furthest extreme edge of pavement and along the cul-de-sac's longitudinal axis. The 1,200-foot length requirement will start over when a public street intersects the non-through street.

Where the proposed motor vehicle traffic volume for a planned development exceeds 1,000 ADT, a secondary public access point is required to the subdivision.

Low volume streets of less than 200 ADT may terminate in a permanent tee or a y-turnaround. All non-residential streets shall be terminated with a cul-de-sac. The tee or y-turnaround design shall be per Standard Details Volume IV and shall permit one driveway connection in each of the 24' width legs of the tee or y-turn around but parking is not permitted within the tee turnaround legs. Warning devices at the end of the tee or y-turnaround are required for safety reasons in accordance with Volume IV.

The following shall be the minimum acceptable radii for cul-de-sac bulbs:

Without Island:

- 45 feet for residential
- 47 feet for non-residential

With Island:

- 52 feet for residential

Note: Islands are permitted within cul-de-sac bulbs in conformance with Standard Details Volume IV and parking is prohibited in accordance with the Howard County Code along the island. Islands are required within cul-de-sac bulbs if the public street is continued by a use in common driveway.

f. Temporary Non-Through Streets

In the event a street may be extended in the future, a temporary tee turnaround shall be provided. The legs of the tee or y-turnaround shall not extend into an existing or future driveway access.

g. Gates and Bollards

In locations where a shared use path may attract motor vehicle traffic, provision of gates or bollards may serve to prevent undesirable vehicular access while allowing passage of bicycles and pedestrians. If bollards are used, a removable bollard should be used such that emergency or maintenance vehicles may access the pathway. Bollards and other obstructions shall not be installed if another strategy can be employed to prevent vehicular access since it is undesirable to locate an object within the pathway. If installed, they must be located where they are clearly visible to approaching bicyclists, with sufficient pathway geometry for a bicyclist to navigate the obstacle without dismounting. There must be a minimum of a 5 feet of clear space (including between removable bollard handles, if applicable) between vertical obstructions for one-way path traffic, and both directions of the path must be accommodated. Bollards and gates should be a bright color, and reflective for both nighttime and daytime visibility. A sample configuration for bollard placement is provided in Figure 2-23.

Figure 2-23. Bollard placement on a shared use path.

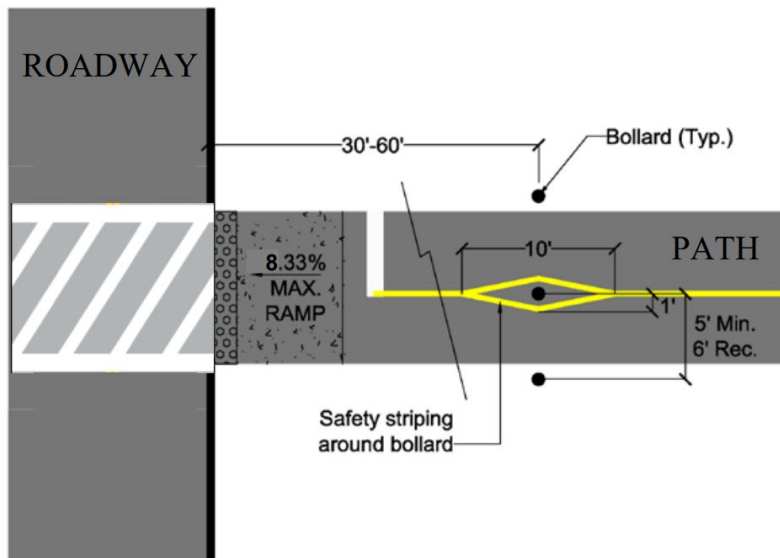

Source: MDOT SHA *Bicycle Policy & Design Guidelines*

4. Superelevation and Transitioning

The relationship between design speed, curvature and superelevation is:

$$R = \frac{V^2}{15(0.01e + f)}$$

Where:

- e = rate of superelevation in percent
- f = side friction factor
- V = vehicle speed, mph
- R = radius of curve, feet

The vehicle speed shall be the design speed set forth in Appendix A for existing roads and the design speed set forth in section 2.1.D.2 for proposed streets

Provision of superelevation is uncommon on County streets and shall be used with discretion, especially on low speed streets in areas where pedestrian activity is expected. Streets with design speeds of 30 mph or greater may be superelevated, and existing streets with superelevation may remain superelevated. Superelevation is required on streets with a design speed of more than 45 mph.

Maximum superelevation rates are dependent upon the type of street, the effect of the superelevation upon vehicles operating at less than the target speed and drainage considerations. Vehicles operating at low speeds may have to steer against the curve to overcome the effect of superelevation, and erratic operation can result. On ice and snow, slow moving vehicles may slide to the inside of the curve if the superelevation rate is too high. In urban areas, the close spacing of intersections and driveways limits the superelevation development. The superelevation rates to be used in the various streets based on design speeds are given in Table 2-15. Also included are minimum radius of curvature.

**TABLE 2-15**  
**MINIMUM RADIUS USING LIMITED VALUES OF**  
**SUPERELEVATION RATES (e) AND SIDE FRICTION FACTOR (f)**

Design Speed (mph)	f	Maximum e %	Minimum Radius (ft)
30	0.20	4	250
35	0.18	4	371
40	0.16	4	533
45	0.15	4	711
50	0.14	4	926
55	0.13	4	1,190
60	0.12	4	1,500
30	0.20	6	231
35	0.18	6	340
40	0.16	6	485
45	0.15	6	643
50	0.14	6	833
55	0.13	6	1,060
60	0.12	6	1,330

Reference: "Green Book" Table 3-7, *Minimum Radius Using Limiting Values of e and f* (Ref. 1).

On curves, values of superelevation and side friction must be distributed to produce a balanced design. The method used is to increase both superelevation and the side friction factor to the maximum values at the sharpest allowable curvature.

The means of transitioning from a normal crown section to a fully superelevated section and then back to a normal crown section is the tangent runout and superelevation runoff. The runoff must be sufficiently long to provide a smooth transition and not appear distorted to the driver. The length of tangent runout shall be such that the outside edge of pavement has the same slope relative to the centerline as that through the superelevation runoff. Two-thirds of the superelevation runoff shall be placed on the tangent and one-third on the curve. Lengths of Superelevation Runoff are shown on Table 3-16, *Superelevation Runoff L<sub>r</sub> for Horizontal Curves*, of the *Green Book*.

Methods of obtaining superelevation are shown in Appendix E1 and E2. Though the means of changing cross slopes are presented in terms of straight lines, the angular breaks shall be rounded in final design to produce smooth pavement edge profiles. Superelevation tables shall be shown on the construction drawings for all subdivision and capital projects and reference all critical stations (P.C., P.T., P.I., full superelevation, etc.).



## B. Vertical Alignment

Vertical alignment shall be designed considering the target speed, design speed, and street type in order to provide a balance between all geometric elements of the street.

The two components of vertical alignment are grades and vertical curves. Minimum grades are established to assure adequate drainage, and maximum grades are established considering the operational characteristics of the design vehicle. Vertical curves must be at least long enough to provide the required stopping sight distance.

Vertical alignment is controlled by a profile grade line (PGL) shown on the contract plans. The PGL shall coincide with the street centerline. For divided street, the PGL shall be the centerline of each travel way.

### 1. Grades

#### a. Minimum

The minimum grade shall be 1.0%. Where a closed section is used, the spacing of inlets must be carefully studied when utilizing the minimum grade to avoid the spreading of storm water across the pavement. Criteria limiting drainage encroachment upon the street are given in the Design Manual, Volume I, Storm Drainage.

#### b. Maximum

As conditions allow, designers should try to achieve a desirable maximum grade of 5% on all roadways except Major Collectors and Arterials. Under no conditions shall the maximum grade for Local Roads, Minor Collectors, and Non-Through streets be greater than 10%. The grade of the cul-de-sac bulb, y- or tee-turnaround shall not exceed 8% within any portion of the cul-de-sac bulb or the y- or tee-turnaround. The maximum pavement cross-slope measured radially through the bulb shall be 6%. The minimum grade for the linear profile shall be 2%.

With the above approach grade requirement, the 10% limit may be extended to an absolute maximum of 12% on Local Roads and Cul-de-Sacs under the following conditions:

- 1) Sufficient justification is presented. Justification should focus on grading, clearing and environmental impact reduction.
- 2) No parking is permitted along this length. Coordination is required with the Department of Planning and Zoning to affirm adequate off-street parking is available.
- 3) Landing grade and related criteria are satisfied.
- 4) Tangent length maximum 450 feet.
- 5) The length of grades may not exceed 450 ft. along the tangent section, and the intersection landing grades must meet AASHTO "Green Book" requirements (Ref. 1). The 12% maximum grade may be used in townhouse or apartment developments if no driveway access is required.

The maximum grade for Major Collectors and Arterials, Country Roads, and Parkways shall be the following:

<u>Design Speed (MPH)</u>	<u>Desirable</u>	<u>Absolute</u>
40	6%	8%
50	5%	7%
60	4%	6%

For interchange ramps, the maximum upgrade shall be 6% and maximum downgrade shall be 7%.

## 2. Vertical Curves

The vertical curve, which is a parabola, is the means by which transitions are made between vertical tangents. A typical curve with the major elements identified is shown in Appendix C, Vertical Curve.

The elevation of any point on the curve may be computed by using the following formula:

$$Y = ax^2 + bx + c$$

Where:

Y = Elevation of the desired point on the curve

$$a = \frac{G2 - G1}{2L}$$

b = G1

c = Elevation of PVC

x = Distance from PVC to point on curve (in stations)

G1 = Grade tangent from the PVC (percent)

G2 = Grade tangent from the PVT (percent)

L = Length of the curve (in stations)

The vertical offset between the tangent and any point on the curve can be determined by the following formulas:

1. Between PVC and PVI:  $y = ax^2$
2. Between PVI and PVT:  $y = a(L - x)(L - x)$

The high or low point of a vertical curve can be found by the following formula:

$$x = \frac{(L)(G1)}{(G1 - G2)}$$

The grade G, at any point on the vertical curve can be determined by the following formula:

$$G = \frac{(G2 - G1)(x)}{L} + G1$$

The six possible types of vertical curves are shown in Appendix D, Types of Vertical Curves. Types I through III are crest vertical curves, meaning the PVI is above the curve, and Types IV through VI are sag vertical curves, meaning the PVI is below the curve.

Whenever vertical tangents change grade, they shall be connected by a vertical curve.

On special circumstances such as critical clearance, the use of asymmetrical vertical curves may be appropriate. These curves are used infrequently and thus the curve data equations have not been included in this manual. Geometrical curve data can be found in numerous highway engineering texts. The use of these curves will require approval from the Department of Public Works or Department of Planning and Zoning.

## a. Crest Vertical Curves

Minimum lengths of crest vertical curves are based on stopping sight distance criteria as shown in Table 2-16 when the height of eye is 3.5 feet and the height of object is 2.0 feet.

The formulas for minimum length of crest vertical curves are:

$$\text{When } S \text{ is less than } L, \quad L = \frac{AS^2}{2158}$$

$$\text{When } S \text{ is greater than } L, \quad L = 2S - \frac{2158}{A}$$

L = Length of crest vertical curve, in feet

S = Stopping sight distance, in feet

A = Algebraic difference in grades, in percent

A graphical relationship between length of the crest curve, algebraic difference in grades and design speed is shown on Figure 3-36, *Design Controls for Crest Vertical Curves* in the "Green Book" (Ref. 1).

**TABLE 2-16**  
**DESIGN CONTROLS FOR STOPPING SIGHT DISTANCE FOR CREST VERTICAL CURVES**

Design Speed (mph)	Stopping Sight Distance (ft)	Rate of Vertical Curvature, K*
15	80	3
20	115	7
25	155	12
30	200	19
35	250	29
40	305	44
45	360	61
50	425	84
55	495	114
60	570	151
65	645	193
70	730	247

\* Rate of vertical curvature, K, is the length of curve per percent algebraic difference in intersecting grades (A).  $K=L/A$

Reference: "Green Book" Table 3-35, *Design Controls for Crest Vertical Curves Based on Stopping Sight Distance* (Ref. 1)

## Passing Sight Distance

Design values for crest vertical curves for passing sight distance will be different than those for a stopping sight distance based upon a different object height. The passing sight distance height uses an object height of 3.5 feet.

The formulas for minimum passing sight distance of crest vertical curves are:

$$\text{When } S \text{ is less than } L, \quad L = \frac{AS^2}{2800}$$

$$\text{When } S \text{ is greater than } L, \quad L = 2S - \frac{2800}{A}$$

L = Length of crest vertical curve, in feet

S = Stopping sight distance, in feet

A = Algebraic difference in grades, in percent

The design controls for crest vertical curves based on passing sight distance are presented in Table 2-17. Comparing these values with design controls for stopping sight distance, these lengths are generally 7 to 10 times greater and are normally impractical to include in a project. Therefore, passing sight distance is generally provided at locations where roadway alignments do not require crest vertical curves.

**TABLE 2-17**  
**DESIGN CONTROLS FOR CREST VERTICAL CURVES BASED ON PASSING SIGHT DISTANCE**

Design Speed (mph)	Passing Sight Distance (ft)	Rate of Vertical Curvature, K* Design
20	400	57
25	450	72
30	500	89
35	550	108
40	600	129
45	700	175
50	800	229
55	900	289
60	1000	357
65	1100	432
70	1200	514

\* Rate of vertical curvature, K, is the length of curve per percent algebraic difference in intersecting grades (A).  $K=L/A$

Reference: "Green Book" Table 3-36, *Design Controls for Crest Vertical Curves Based on Passing Sight Distance* (Ref. 1).

## b. Sag Vertical Curves

Headlight sight distance (HLSD) is used to determine the length of sag vertical curves. When a vehicle enters a sag vertical curve at night, the roadway lighted ahead of the driver depends on the height of the headlight and direction of the headlight beam.

Headlight sight distance is measured with a headlight height of 2 feet and a 1-degree upward divergence of the light beam.

Minimum lengths of sag vertical curves shall therefore be based upon a headlight sight distance equal to the stopping sight distance.

The formulas for minimum length of sag vertical curves, based upon this criterion, are:

$$\text{For } S \text{ is less than } L, \quad L = \frac{AS^2}{400 + 3.5S}$$

$$\text{For } S \text{ is greater than } L, \quad L = 2S - \frac{400 + 3.5S}{A}$$

L = Length of sag vertical curve, in feet

S = Stopping sight distance, in feet

A = Algebraic difference in grades, in percent

The design controls for sag vertical curves are presented in Table 2-18.

**TABLE 2-18**  
**DESIGN CONTROLS FOR SAG VERTICAL CURVES**

Design Speed (mph)	Stopping Sight Distance (ft)	Rate of Vertical Curvature, K* Design
15	80	10
20	115	17
25	155	26
30	200	37
35	250	49
40	305	64
45	360	79
50	425	96
55	495	115
60	570	136
65	645	157
70	730	181

\* Rate of vertical curvature, K, is the length of curve per percent algebraic difference in intersecting grades (A).  $K=L/A$

Reference: "Green Book" Table 3-37, *Design Controls for Sag Vertical Curves* (Ref. 1).

A graphical relationship between length of the crest curve, algebraic difference in grades and design speed is shown on Figure 3-37, *Design Controls for Sag Vertical Curves* of the *Green Book* (Ref. 1).

### 3. Critical Length of Grade

It is necessary to consider, in addition to maximum grade, the effect of length of grade upon vehicle operation. Though most passenger cars can climb fairly steep long grades with little difficulty, trucks generally undergo a substantial reduction in speed which can result in a reduced level of service and increased crash potential. The maximum length of designated upgrade that a loaded truck can travel without an unreasonable reduction in speed is termed the "critical length of grade." Major collectors in commercial or industrial areas and all arterials shall be checked for critical length of grade.

The maximum permissible speed reduction shall normally be 15 mph. Where the upgrade is preceded by a substantial downgrade, vehicle speeds are likely to be higher at the bottom of the upgrade, and the maximum permissible speed reduction may then be as great as 20 mph.

A relationship between speed reduction, percent of grade, and length of grade is shown on Figure 3-21, *Critical Lengths of Grade for Design* in the *Green Book*. Whenever a design exceeds the critical length of grade, the grade shall be reduced, the length reduced, or a climbing lane added.

For grades steeper than shown on Figure 3-21 but within allowable criteria, the critical length of grade shall be 450'.

Factors to be considered in designing the end of a climbing lane include average running speed, topography and sight distance. In no case shall the climbing lane be ended prior to a point at which the truck can attain a speed of at least 30 mph.

### 4. General Controls for Vertical Alignment

In addition to the specific criteria presented in previous sections, there are a number of general controls applicable to vertical alignment.

- a. In selecting the vertical alignment based on a given design speed, use of the maximum gradient and minimum length of curve for that speed should be avoided.
- b. The length of a vertical curve shall not be less than three times the design speed in mph and shall provide no less than the required stopping sight distance.
- c. A smooth profile grade, consistent with the topography, shall be strived for in preference to a grade with numerous breaks and short lengths of tangent.
- d. The profile shall be such that hidden dips, hazardous to passing maneuvers, are avoided.
- e. Short tangents between vertical curves should be avoided. A more pleasing alignment can be attained by lengthening the curves to eliminate the tangent.
- f. Where there is an at-grade intersection on a highway with a steep grade, the gradient should be reduced through the intersection to aid turning vehicles and reduce hazards.



## 2.4 Intersection Design

### A. General

Intersections must be designed to safely and efficiently accommodate all modes of travel. This section contains the geometric design elements applicable to intersections, the procedures to be followed in developing the best possible design layout, and the information required on the construction drawings. Roundabouts are also discussed in this section.

### B. Geometric Design

#### 1. Location and Spacing

Streets should be so located that sufficient length is provided between intersections for weaving, storage and associated land uses. The minimum intersection spacing, measured along the through roadway between centerline of intersecting roadways including roundabouts, shall be as indicated in Table 2-19. Traffic analysis may indicate that the minimum intersection spacing must be exceeded to provide acceptable operations.

**TABLE 2-19**  
**MINIMUM INTERSECTION SPACING**

Functional Classification of Through Road	Minimum Intersection Spacing (Centerline to Centerline)
Principal Arterial	To be in accordance with MDOT SHA Criteria
Intermediate Arterial	
Divided	Median Crossover: 1600'
Undivided	Tee Intersection: 750'
Minor Arterial:	750'
Major Collector	500'
Minor Collector	250'
Access Street	250'
Public Access Place	N.A.

Note: Intersection spacing is the distance between any two public or private streets as located on the specified through street

The minimum values in Table 2-19 may be modified during the development of a master planning process.

Street location must provide adequate intersection sight distance as described in Section 2.1.E.3.

A midblock crossing may be considered when diversion of pedestrians and bicyclists to other crosswalks is unlikely. Human nature and changing local land use patterns may result in increased pedestrian crossings at locations where the roadway was not designed to safely accommodate such unanticipated crossings. In these scenarios, Designers shall apply FHWA's guidance for the purpose of retrofitting such locations with a safe crossing and may include reclassification of the street type or introduction of traffic calming measures in response to pedestrian behavior and changing land use contexts. Criteria for evaluation of midblock crossings are discussed in Section 5.2.C and geometric design guidance is provided in Section 2.4.E.3.d. Studies to evaluate midblock crossings, including potential medians, are discussed in Section 5.2.C.1.

## 2. Skew Angle and Horizontal Curvature

Street centerlines shall intersect between 80 degrees and 100 degrees and continue through the intersection without offset or break.

In order to prevent drainage problems from being created along the fillets of two intersecting streets, spot elevations and flow arrows should be provided to ensure positive drainage along the fillet.

## 3. Design and Control Vehicles and Turning Paths

Many intersection design details, such as curb radii and island locations, depend upon the choice of the design and control vehicle. The control vehicles require larger curb radii and wider lane widths between islands than do design vehicles. Information on design and control vehicles, including guidance for their selection, is provided in Section 2.1.D.3. Turning paths for the various design vehicles are shown in the *Green Book*. For non-standard intersections or street termini, a turning template showing adequate turning radius of the design vehicle and control vehicle shall be provided.

## 4. Minimum Curvature for Turning Movements

Guidance and turning templates referenced in Section 2.1.D.3 shall be used to determine curb radii for turning movements. Curb radii should be as small as possible to reduce turning speeds and minimize the distance that pedestrians and bicyclists need to travel to cross the roadway opening, while adequately accommodating the design vehicle and control vehicle. The Designer shall select the design vehicle and control vehicle based on Section 2.1.D.3, including considerations for unique characteristics of the intersection, and illustrate how turning templates for the design vehicle and control vehicle are applied to the intersection.

The characteristics of each intersection must be considered such that the actual curb radius provided is not excessive, while accommodating the effective radius of a turning vehicle, which is typically larger. See Figure 2-24 regarding the relationship between actual curb radius and effective radius.

Figure 2-24. Actual Curb Radius and Effective Radius.

Source: Modified from San Francisco "Better Streets Plan"

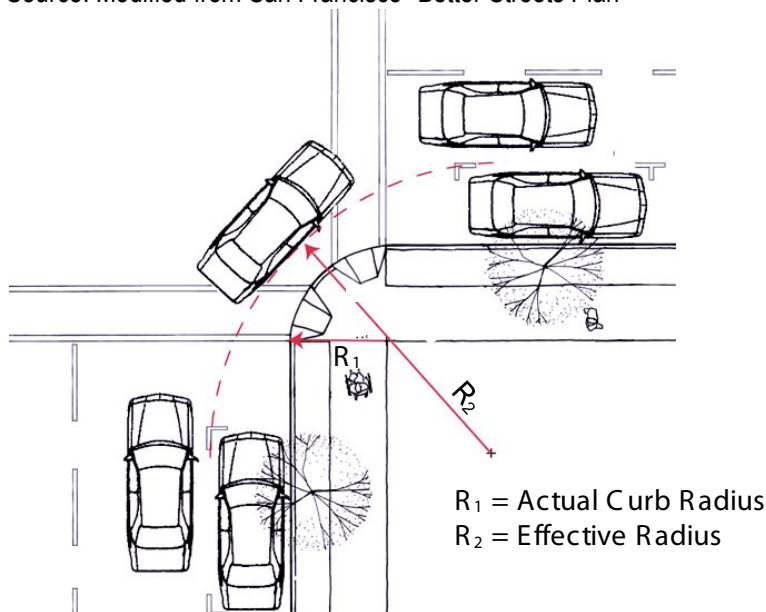

On roadways where parking, bike lanes, or shoulders are provided, small actual curb radii are capable of accommodating the effective turning radius of the design vehicle. Table 2-20 presents *minimum radii* for these conditions where intersections meet at a 90-degree angle without adjacent roadway curvature. Where the curb is provided immediately adjacent to the through travel lane on either roadway, or where curb extensions are provided at an intersection, larger radii, additional pavement, and/or a truck apron will typically be required to accommodate the design and control vehicles. The designer must evaluate if curb extensions with larger radii provide the best overall design to accommodate all users of the intersection, with safety for pedestrians and bicyclists as the central focus.

**TABLE 2-20**  
**MINIMUM CURB RADIUS FOR INTERSECTION**

*Note: This table must be used in conjunction with technical analysis; refer to text in this section for critical guidance on intersection curb radius design*

Receiving Roadway Street Type*	Radius (feet)	Design Vehicle	Control Vehicle
Neighborhood Yield Street Rural Development Street Alley	15	P	BUS-40
Boulevard with Parking Neighborhood Connector with Parking Neighborhood Street 1 with Parking Country Road	15	SU-40	Refer to Table 2-2
Town Center Connector with Parking Town Center Street with Parking Neighborhood Street 2 with Parking	20	SU-40	Refer to Table 2-2
Industrial Street	50	WB-62	N/A
Parkway*	Consult DPW	WB-62	N/A
Boulevard no Parking Town Center Connector no Parking Town Center Street no Parking Neighborhood Connector no Parking Neighborhood Street 1 no Parking Neighborhood Street 2 no Parking	Evaluation Required	SU-40	Refer to Table 2-2

\* Note: Consult DPW for criteria when a Parkway is either the receiving or departing roadway

The above radii are based on a 90-degree turning angle and the actual angle and curvatures proposed must be evaluated using turning templates or standard industry software for all intersections and submitted to the County for review. The designer should typically use a 10 mph turning speed for passenger vehicles and a 5 mph turning speed for all other vehicles for the turning template analysis at intersections.

The design vehicle must be expected to stay within their intended origin and receiving lanes when making turns on all roadways, although the design vehicle may use shoulders, pavement widening strips, or tapered pavement to access the receiving lane without crossing the receiving roadway's centerline. Some vehicles turning from higher classification roads onto Neighborhood Yield Streets, Alleys, or Rural Residential Streets, may find it difficult to stay in the appropriate lane without crossing the centerline, due to the relatively narrow residential road standards. However, the design must ensure that these vehicles, up to and including the size of the control vehicle, can stay within the intended driving surface, including paved areas and truck aprons as appropriate. It is expected that the driver will use caution when making these maneuvers and wait until there is a sufficient gap in motor vehicle traffic to safely negotiate the turn.

Curbing shall be provided at intersections in which the design vehicle must encroach upon adjacent lanes when making turning maneuvers.

In some instances, intersections shall be required to flare the pavement width for a short distance in order to allow the design vehicle to make the turn and stay on the pavement. Alternately, the intersection may feature a truck apron to accommodate infrequent larger vehicle turning movements provided that the apron does not overlap with a designated pedestrian or bicycle path. The designer shall demonstrate that there is sufficient pavement width where encroachment into adjacent lanes occur. Roadways with classifications of minor collector and above should have sufficient pavement width to prevent encroachment of the design vehicle into adjacent lanes. However, the control vehicle will be permitted to use the entire pavement area of the receiving roadway provided that sufficient intersection sight distance is available. Recessing stop bar placement may be evaluated where encroachment into the opposing lane would regularly need to occur across the centerline at a stop-controlled intersection, but caution should be used to ensure that sight distance is adequate for the type of intersection control.

When the receiving roadway has two or more lanes in the receiving direction and an acceleration lane is not provided, the full width of the roadway may be assumed to be available to vehicles making the turning movement. Passenger vehicles shall be accommodated turning from the right-most lane into the right-most lane.

For intersections or portions of intersections that do not have curb, the design of the location of the edge of pavement shall follow the same procedures as the design of curb as described in this section.

## 5. Intersection Sight Distance

The sight distance required at intersections is presented in Section 2.1.E.3.

## 6. Auxiliary Lanes

Auxiliary lanes at intersections are used to increase motor vehicle capacity and safety by allowing speed change and vehicular storage outside of the through travel lanes. Auxiliary lanes should be minimized to the extent possible, as they result in wider streets with faster motor vehicle traffic, leading to conditions that are less comfortable for people walking, bicycling, and accessing transit vehicles. However, they are appropriate when the safety of all users of the street is improved by their use, or when an intersection would otherwise have unacceptable operations and safety can be adequately provided for all modes.

When an auxiliary lane is provided, it should not interrupt the provision of bicycle accommodation through the intersection. A combined right turn/bike lane, detailed in Section 2.4.G.3, should be utilized in locations where there is not sufficient space to maintain a full width on-road bike lane and right-turning lane.

### a. Auxiliary Lane Types

There are several types of auxiliary lanes:

1) Left-turn lanes.

Left turn lanes at intersections provide a space for motor vehicle deceleration, provide storage outside of through traffic, and reduce rear-end exposure while providing a comfortable means for making a left turn. They can provide space for bicyclists using the roadway to wait to make a left turn, reducing their exposure in the through lane; also, they can avoid situations where through motor vehicle traffic may otherwise choose to cross to the right into a bicycle lane or onto a shoulder to move around a vehicle waiting to turn left. On street types with medians, left turn lanes may be provided by reducing the width of raised median; however, left turn lanes may not be necessary to turn from a low-volume street onto another low-volume street.

2) Right-turn lanes on signal or stop condition approaches

Similar to left turn lanes, right turn lanes can allow motor vehicle deceleration outside of the through travel lane and can allow storage of right turning vehicles when the right turn lane has independent signal control, such as when a shared use path may delay a green indication for right turning vehicles while the through movement has a green signal indication concurrent with the shared use path crossing. Right turn lanes must provide for bicycle accommodation through the intersection, as applicable, in accordance with section 2.4.G. Right turn lanes should only be provided where necessary to provide acceptable intersection operations.

3) Right-turn lanes on free-flow approaches

These lanes provide the ability for vehicles to decelerate outside of the through travel lane to make a turn where the turning traffic has vehicular right-of-way, such as a turn from the major street where the minor street has stop control. Thus, storage in the right turn lane is only necessary if right turning vehicles are expected to frequently encounter a pedestrian or bicyclist using the crosswalk across the receiving street. Right turn lanes on free flow approaches are generally not necessary on roadways with a design speed less than 40 mph and should only be provided where necessary to provide minimum acceptable safety and operation of through traffic.

4) Acceleration lanes

Auxiliary acceleration lanes departing intersections are not recommended. Acceleration lanes provide the ability for vehicles to accelerate outside of the through traffic lanes on a street, such that motor vehicle traffic can merge into through lanes at or near the operating speed of the through street. Few Howard County streets would benefit from the provision of acceleration lanes, and they must be designed carefully to consider safety and operations of all modal users of the street. The use of acceleration lanes shall only be approved by the Department of Public Works when determined to be warranted by a traffic study.

5) Weave lanes

When the acceleration lane from one intersection continues to the turn lane for the subsequent intersection, a weave lane is created. As with acceleration lanes, weave lanes are not recommended and are expected to be rare on Howard County streets; their use shall be approved by the Department of Public Works when determined to be warranted by a traffic study.

b. Auxiliary Lane Requirements

Auxiliary lanes shall be considered under any of the following conditions while balancing the safety needs of all users of the street:

- 1) The design speed of a new or retrofit street, operating speed of an existing street, is 40 mph or more and vehicles waiting to turn left or right would pose a hazard to through traffic. Either a channelized additional lane or a lane within a raised protective median may be required.

- 2) Where a large number of passengers load or unload from passenger cars.
- 3) Where a Traffic Study has determined that an auxiliary lane is required.
- 4) For warrants for auxiliary lanes at driveways, see Section 2.5.

In any of these cases, a left- or right-turn lane may be desirable. The Department of Public Works may require inclusion or exclusion of an auxiliary lane based on review of the traffic analysis and needs of all users of the street.

c. Auxiliary Lane Width

Refer to the typical cross sections for the required width of median auxiliary lanes. For auxiliary lanes not shown on the typical sections, auxiliary lane widths shall match the width of the adjacent through travel lane. In closed sections, this width shall be measured to flowline.

d. Auxiliary Lane Length

If provided, the minimum length for acceleration lanes shall be in accordance with “Green Book” Table 10-4, *Minimum Acceleration Lengths for Entrance Terminals with Flat Grades of Two Percent or Less*.

The length of a right turn lane or left turn lane is composed of three parts: entering taper, deceleration lane and storage length. The total length should be the sum of those three lengths.

1) Turn Lane Taper and Deceleration Lengths

The combined length of the entering taper and deceleration lane shall be as shown in Table 2-21.

**TABLE 2-21**  
**LANE CHANGE AND DECELERATION DISTANCES**  
**(Note: Storage Length Not Included and Must Be Added)**

Design Speed (mph)	Lane Change and Deceleration Distance (ft)
25	105
30	150
35	205
40	265
45	340
50	415
55	505
60	600

Reference: “Green Book” Table 9-20, *Desirable Lane Change and Deceleration Distances* (Ref. 1).

On closed sections, the taper of an auxiliary lane shall be consistent with AASHTO. The taper shall consist of reverse symmetrical curves and be approximately the length required by AASHTO. The initial speed of acceleration lanes and the final speed of deceleration lanes shall be 15 mph if the vehicle will encounter a “free flow” condition – although the actual turning speed at the intersection shall follow guidance in Section 2.4.B.4. Initial deceleration or final acceleration commonly occurs in the through lane, allowing use of Table 2-21.



## 2) Turn Lane Storage Lengths

The minimum length of the portion of the left turn lane or right turn lane required for storage depends upon motor vehicle traffic volumes, type of vehicles, and signalization. To be fully effective, the turning lane must be sufficiently long to assure that vehicles in it do not block the through lanes. At signalized intersections, a line of stored through vehicles should not block its entrance. The length shall be consistent with the traffic study evaluation.

At unsignalized intersections, where turning traffic cannot make a free turn, the length of storage in right-turning lanes shall be sufficient to accommodate the average number of vehicles arriving during a two-minute period within the design hour, and the length of storage in left-turning lanes shall be sufficient to accommodate the average number of vehicles arriving in a 5-minute period within the design hour.

At signalized intersections, the minimum length of storage of right-turning lanes shall be that required to accommodate the average number of turning vehicles arriving per cycle and the minimum length of storage of left-turning lanes shall be that required to accommodate twice the average number of turning vehicles arriving per cycle. In the absence of definite knowledge of the cycle length, it shall be assumed to be 75 seconds.

Also, at signalized intersections, to ensure that the entrance of an auxiliary lane is not blocked by stopped through vehicles, the length required to store 1.5 times the average number of through vehicles arriving per cycle shall be determined, and if it is greater than the length of auxiliary lane otherwise required, it should be used as the minimum length. The taper shall be in addition to this length requirement.

The results of a detailed queue analysis may be substituted for the above length requirements.

The length required to store each passenger car is 20 feet and each truck and bus 50 feet. Traffic volumes shall be determined by methods contained in Chapter 5.

## 7. Turning Roadways

The main controls on the design of turning roadways (connecting roadways for traffic turning between two intersection legs) are radius of the inside edge of pavement and width of roadway. The relationship between roadway width, curvature and design vehicles is specified in "Green Book" Table 3-27, *Design Widths of Pavements for Turning Roadways* (Ref. 1).

Widths of turning roadways shall be based on *Green Book* Table 3-27 in accordance with the following:

1. Traffic condition B shall normally govern design.
2. Case 1 may be used to determine the width of turning roadway only where the island formed by the roadway is less than 25 feet long.

The minimum sight distance on turning roadways shall be equal to the stopping sight distance.

The length of crest and sag vertical curves needed to satisfy this sight distance requirement shall be in accordance with Section 2.3.

## 8. Median Lanes and Openings

A median lane is a left-turning auxiliary lane located within the median, and the determination of its need, as well as its geometry, such as length and width, shall be as for any auxiliary lane.

Where the turning volume is sufficiently high, as determined by a level of service analysis, queue analysis, and if the median width is large enough, two left-turn lanes may be provided, each being the width of a normal turning lane. The receiving leg of the double left-turn shall be sufficiently wide to receive the two turning lanes of traffic without undue hazard. This width is dependent upon type of turning vehicles and angle of the turn.

Though median openings should usually be provided at intersections with cross streets and major traffic generators, such factors as close intersection spacing or long left-turn lanes may make this infeasible. An analysis of the projected traffic volumes and the street network shall be conducted to determine the recommended location of median openings.

The design of the median opening is based on the path of the design vehicle performing a minimum left turn at 10 to 15 mph. Should the volume and type of vehicles performing the left turn movement require a higher speed than the minimum, the design should be made to use the radius of turn based on the appropriate speed.

The median opening design should be checked to assure that opposing left turns can be made without conflict.

A semicircular end shall be used on all median islands 6 feet or less in width.

For widths greater than 6 feet, a bullet nose shape, as shown in *Green Book* Figure 9-43, *Above-Minimum Design of Median Openings (Typical Bullet Nose Ends)*, shall be used.

The ends of median islands shall be depressed to 2 inches above the pavement using the MDOT SHA details and shall have a radius equal to  $M \times 15$ , where  $M$  is the median width. In no case shall the length of the median opening be less than the cross-street width plus 8 feet.

## 9. Traffic Islands

Traffic islands are most commonly used where right turn lanes are channelized to facilitate free flow of right turns. The high speed of these turning movements is not compatible with the safety and comfort of people walking and bicycling. For that reason, provision of channelized right turn lanes with traffic islands is discouraged and when provided, design should encourage low motor vehicle speeds. Before a channelized right turn lane is proposed, alternative configurations must be assessed to demonstrate why channelization is preferable to an unchannelized right turn.

Where channelized right turn lanes are needed, such as where there are acute angles between intersection legs, a number of treatments should be used to foster the safety and comfort of people walking and bicycling across the right turn lane.

- The geometry of the channelized right turn lane should be evaluated to create a tighter angle of traffic at the intersection of the receiving street such that vehicles will be more perpendicular to the receiving street from within the channelized lane. This configuration reduces the speed of turning motor vehicles and makes it easier for drivers of those vehicles to see other users in their path. An example of a lower angle channelized right turn lane is provided in Figure 2-25, but site constraints may require alternate geometry. The proposed geometry must be designed in the context of the various intersection elements, such as signal pole placement, appropriate pedestrian refuge space, location of utility poles, and placement of regulatory signs, as well as in the context of the surrounding environment.

Figure 2-25. Lower Angle Channelized Right Turn Lane Configuration.

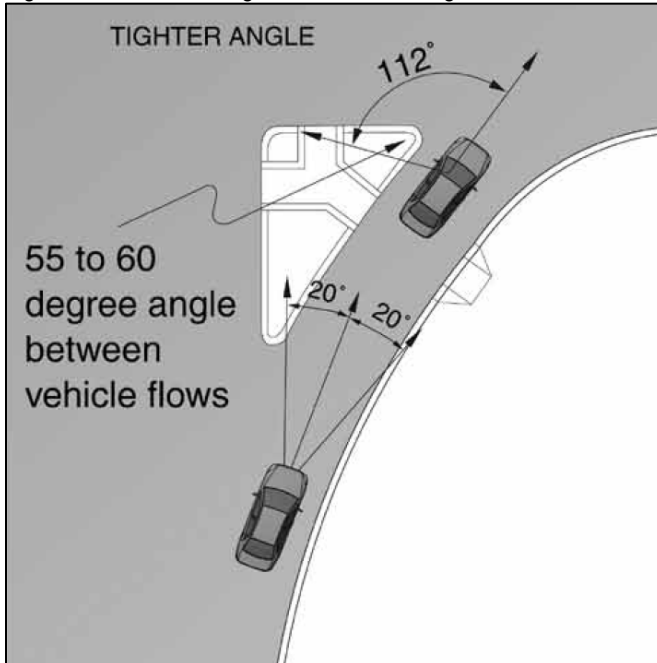

Source: Institute of Transportation Engineers

- The lane should be as narrow as possible to accommodate the design vehicle for the lower classification roadway at the intersection. The preferred width of pavement is 11 feet, but the designer is required to verify that the design vehicle can be accommodated within the specific geometry proposed for the lane. To accommodate larger vehicles, truck aprons as described in Section 2.2.E.10 may be used. In most cases, a crosswalk will be provided across the channelized turn lane with its initial construction, or should be planned for as a future condition. If a crosswalk is to be provided across the lane upon initial construction or in the future, the design vehicle and control vehicle shall be accommodated within the channelized turn lane from the beginning of the channelized turn lane to, at a minimum, the location of the crosswalk such that the design vehicle and control vehicle can remain within the pavement at the location of the pedestrian crossing. A standard curb and gutter shall be provided, at a minimum, along this portion of the channelized lane. Beyond the crosswalk, a mountable truck apron can be provided as shown in Figure 2-26 to accommodate the control vehicle on one or either side of the lane provided that there is clear delineation between the apron area and areas reserved for pedestrian and bicycle use. This delineation shall be provided by, at a minimum, a standard curb and gutter at the outside of the truck apron; a buffer between sidewalk and the apron is recommended.

Figure 2-26. Potential Truck Apron Location for Channelized Right Turn Lanes

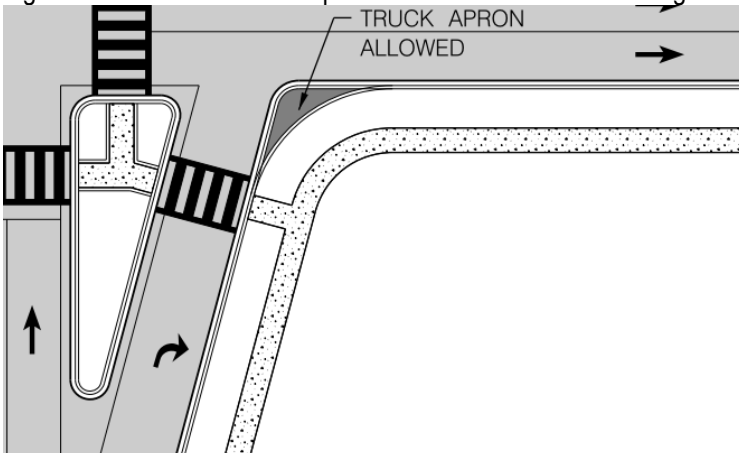

- Sidewalk or shared use path passage through the island shall comply with ADA accessibility requirements.

Additional considerations for traffic islands are as follows.

- All islands with an area of at least 75 square feet shall be raised and bounded by a standard curb or combination curb and gutter. Islands with areas less than 75 square feet are not recommended. If the geometry of the intersection requires the use of such a small island, it shall have a normal pavement section and be demarcated by pavement markings.
- Divisional islands, which are islands separating opposing traffic flows within the intersection area, shall be a minimum of 4 feet wide. The offset from the edge of travel lane to the approach nose shall be at least 3 feet.
- The approach noses of traffic islands shall be depressed to 2 inches above the pavement.
- On islands adjacent to turning roadways, the approach nose shall be offset at least 4 feet from the edge of the adjacent through lane and a minimum of 2 feet from the edge of the turning roadway.
- The nose radii of triangular islands shall be 2 feet, except the right-angle corner, which shall have a 5-foot radius. The approach nose of divisional islands shall have a 1-foot radius, offset as discussed above. The end of a divisional island shall be in accordance with median openings.
- All divisional islands, six feet or less in width, as well as triangular islands of less than approximately 150 square feet, shall be paved or planted with low maintenance landscaping materials, provided that the ultimate height does not conflict with line of sight and ultimate spread does not conflict with gutter drainage.
- Divisional islands wider than 6 feet, and triangular islands greater than 150 square feet in area shall be seeded and mulched or sidewalks shall be included where directed by the Department of Planning and Zoning or deemed necessary for a safe pedestrian crossing by the Department of Public Works.

#### 10. Intersection Sight Distance

Requirements for Intersection Sight Distance evaluation are presented in Section 2.1.E.3

#### 11. Intersection Vertical Alignment

Typical section pavement slopes of the street with the higher functional classification shall be carried through the intersection without deviation. The pavement slopes of the street with the lower classification shall be warped to meet the pavement edge of the through street. Where two streets of the same classification intersect, they shall be connected by transitioning both streets.

As discussed above, one of the intersecting streets shall be determined to be the more important and its grade carried through the intersection without interruption. The grade of the other street as it descends to the through street shall be considered a landing grade. Landing grade shall meet the criteria in Table 2-22. However, where possible, it is preferable that the landing grade provide a 2% cross slope through the marked or unmarked crosswalk area of the intersection.

**TABLE 2-22**  
**MAXIMUM INTERSECTION LANDING GRADES AND DISTANCES**

<u>Functional Classification</u>	<u>Maximum Landing Grade</u>	<u>Distance From Intersection*</u>
Arterial	+3.0%	200'
Collector	+3.0%	175'
Local, Cul-de-sacs	+4.0%	40'**

\*Distance measured from pavement edge of intersection roadway to the PVC of the vertical curve

\*\*No landing grade is required if the tangent is not greater than 4%

The vertical alignment of streets intersecting with State Highways is discussed in Section 2.4.K.

**C. Roundabouts**

Roundabouts are circular intersections with specific design and traffic control features. These features include yield control of all entering traffic, channelized approaches, and appropriate geometric curvature to ensure that travel speeds on the circulatory roadway are typically low. Parking is prohibited within the roundabout and on its approaches. The center island of a traditional roundabout features a mountable truck apron and a raised island in the center of the roundabout that is not traversed by vehicular traffic.

Figure 2-27. Roundabout.



Source: Howard County



Mini-roundabouts have many of the same characteristics of traditional roundabouts, except that they have a smaller size and more compact geometry. Due to the compact geometry, the entire center island of a mini-roundabout is a mountable truck apron, as the control vehicle will need to traverse the island to make a left turn. Mini-roundabouts are single-lane roundabouts that are typically installed on roads with design speeds of 30 mph or less and are not suitable for areas with high volumes of trucks.

Figure 2-28. Mini-Roundabout.



Source: Howard County

The advantages of a properly located and designed roundabout over other intersection traffic control devices include:

- Improved intersection operation – roundabouts can accommodate higher left-turn volumes than other intersection control devices.
- Lower crash rates and crash severity – roundabouts reduce the number of traffic conflict points and vehicle speeds and provide a clearer indication of the driver's right-of-way compared to other intersection traffic control.
- Improved aesthetics – roundabouts provide an opportunity to improve the aesthetics of an intersection with landscaping in connection with community enhancement projects.

It is important to distinguish that these distinct features of a roundabout are not applicable to other circular intersections, such as rotaries and neighborhood traffic circles.

Curb shall be used on all roundabouts for purposes of channelization, regardless if the approaching intersecting streets are curbed.



For both traditional roundabouts and mini-roundabouts, an examination of pedestrian and bicycle accommodation is critical; pedestrian and bicycle pathways within roundabouts should be clearly defined and crossing measures should be enhanced to encourage motorists to yield the right of way. For streets which feature on-road bicycle accommodation, bicyclists should have the option to traverse the circulatory road of the roundabout, or to bypass the roundabout via an off-road bicycle or shared use facility, through a bicycle transition to the shared use facility (See Section 2.2.D.3) on all approach and departure legs of the roundabout. However, bicyclists can ride in the roadway with motor vehicle traffic to traverse the roundabout if they prefer. For more information on the design of roundabouts to accommodate bicycle facilities, refer to the AASHTO “Guide for the Development of Bicycle Facilities” (Ref. 7).

In areas with sidewalks, roundabouts must be designed accommodate the needs of pedestrians with visual disabilities, since typical audial cues of vehicles stopping and starting are not as clear where vehicles yield as opposed to stopping. Thus, the orientation of ramps crossing the roadway is especially critical to guide pedestrians across the vehicular lanes. Where a splitter island can be introduced on the roundabout approaches, it should be designed to provide a pedestrian refuge, and walkway edges should be well defined. Pavement markings for the crosswalk shall be provided in accordance with Section 2.4.E.1 and Lighting shall be provided in accordance with Section 2.7.

All roundabout studies and design shall be conducted in conformance with MDOT SHA’s “Roundabout Design Guidelines” and the NCHRP Report 672 “Roundabouts: An Informational Guide Second Edition,” or latest editions (Ref. 20, Ref. 16).

#### **D. Alternative Intersection Types**

Evaluation of alternative traffic control devices (e.g., turn restrictions, channelized left-turn “Florida-T”/half signals, continuous flow intersections) shall be conducted only at the discretion and under the direction of the Howard County Department of Public Works. FHWA’s “Intersection Control Evaluation (ICE)” tool shall be used to evaluate alternative intersection types (Ref. 21).

#### **E. Pedestrian Design Elements at Intersections and Midblock Locations**

Intersections frequently provide the greatest number of potential conflict points between pedestrians and motorists. This section addresses crossings both at controlled and uncontrolled intersections and at midblock locations.

##### **1. Crosswalks**

Crosswalks exist at many locations in the County whether they are marked or not. According to the *Code of Maryland*, Title 21, Section 101, Crosswalk means that part of a roadway that is:

- 1) Within the prolongation or connection of the lateral lines of sidewalks at any place where two or more roadways of any type meet or join, measured from the curbs or, in the absence of curbs, from the edges of the roadway;
- 2) Within the prolongation or connection of the lateral lines of a bicycle way where a bicycle way and a roadway of any type meet or join, measured from the curbs or, in the absence of curbs, from the edges of the roadway;  
or
- 3) Distinctly indicated for pedestrian crossing by lines or other markings.

Through consultation with the Department of Public Works, providing a marked crosswalk is appropriate in a variety of locations, including at signalized intersections, at crossings along designated school walking routes, or at non-signalized crossing locations where the amount of pedestrian/motor vehicle traffic and the configuration of the area make the use of a marked crosswalk desirable for directing pedestrians to safely cross the street. However, marking of all crosswalks is not required by State Law, and marking of crosswalks is not always appropriate. When crosswalks are marked, a ladder style crossing shall be used as illustrated in Figure 2-29. These markings consist of two elements. Transverse markings include two parallel stripes 12 inches wide parallel to the direction of walking travel delineating the outside of the crosswalk. Parallel markings are 2-foot-wide stripes placed 2 feet apart parallel to the direction of motor vehicle travel.

Figure 2-29. Ladder crosswalk.



Source: Howard County

Crosswalk width shall be 8 feet from outside edge to outside edge, or the width of the sidewalk or shared use path to which it connects, whichever is greater. The inner edges of the crosswalk edgelines must encompass the entire depressed curb section of the accessible ramp. Crosswalk markings shall be white permanent preformed thermoplastic pavement markings to allow for good visibility in a variety of conditions. Alternate crosswalk surface treatments such as brick pavers or stamped concrete must be approved by the Department of Public Works, and, the alternative material must be bounded by two 12-inch white permanent preformed thermoplastic pavement marking edge lines. Any alternatives to the standard ladder crosswalk shall be considered through the Exceptions process. The MdMUTCD provides additional guidance on crosswalks, including placement of signs at and in advance of crosswalks.

See Section 2.4.B.9 for information on “daylighting,” or setting back on-street parking from crosswalks to enhance visibility.

## 2. Curb ramps

When designing the geometric layout of curb ramps at an intersection, the designer must consider the presence of existing or funded sidewalks and shared use paths. Each ramp and crossing to be provided must have a clear destination. The designer must also reference applicable bicycle, pedestrian, and corridor master plans and develop a layout that does not preclude development of future ramps or crosswalks to accommodate future needs. Accommodation shall be made for all required pedestrian movements at each intersection by providing an accessible route. At low volume intersections where the higher classification roadway is uncontrolled, reasonable pedestrian accommodation with little or no inconvenience to pedestrians may be provided by only providing one crossing of the higher classification roadway.

Curb ramps shall comply with ADA access requirements, including maximum (12:1) ramp slopes, 5'x5' landing areas, and detectable warning surfaces; see Volume IV for details of various ramp configurations. It is preferred that when

crossings are oriented across the adjacent two legs of the intersection, each corner should have two curb ramps, with each one pointing in each direction of travel across the adjacent leg of the intersection.

Where site constraints dictate that two curb ramps per corner are not feasible, alternative designs may be considered using a single ramp. Examples of factors that may constrain curb ramp locations include utility poles or other features, drainage inlets, signal poles or cabinets, etc. For new construction or major reconstruction, these features should be relocated to provide the preferred curb ramp configuration. In retrofit situations, an alternative curb ramp layout may be needed.

Curb ramps and adjacent paved areas shall be graded to avoid ponding of stormwater runoff in the path of pedestrian travel.

### 3. Signalized intersections

#### a. Crosswalk placement at signalized intersections

Where sidewalks or shared use paths exist or are funded or programmed to be installed within one year, marked, signalized crosswalks shall be provided across all legs of signalized intersections. If a sidewalk or shared use path is not funded or programmed to be installed within one year, but are included in a master plan, the intersection layout shall be designed to accommodate the future crosswalk(s) and all related appurtenances. In cases of significant site constraints, absence of a pedestrian destination, or other extraordinary circumstances, elimination of one or more crosswalks may be considered through the Exceptions process.

#### b. Pedestrian detection

Most signalized crosswalks in the County use pedestrian pushbuttons to signal that someone is waiting to cross. All Howard County signalized intersections with marked crosswalks have countdown pedestrian signals (CPS). The Howard County standard is for pedestrian detection to be provided by accessible pedestrian signals (APS), which includes a pushbutton locator tone, a tactile arrow, a speech walk message, and a pedestrian education sign. Additional guidance on APS is provided in Sections 4E.09 through 4E.13 of the MdMUTCD.

When a signal is programmed with pedestrian recall, a WALK indication will be displayed during each respective signal cycle without the need for a person to press a pushbutton. This improves the probability that a pedestrian or cyclist will arrive at the intersection with a green signal and reduces their wait times. Pedestrian recall should be considered at all signalized crosswalks, especially in mixed use areas (Town Center Street, Town Center Connector, and Boulevard street types) and where observed or planned walking volumes are high. Where pedestrian recall time is less than the minimum green time for the major street, pedestrian recall should always be used. Use of pedestrian recall must be approved by the Department of Public Works.

When signal timing is selected, strategies for reducing pedestrian wait times to cross the street will be considered in areas with pedestrian accommodation.

#### c. Alternative pedestrian signals

Alternative pedestrian signal phasing beyond standard pedestrian signal phasing can include leading pedestrian intervals.

A leading pedestrian interval (LPI) entails retiming the signal splits so that the pedestrian WALK signal typically begins 3 to 7 seconds before the motor vehicle green, although an analysis of the intersection may identify that a longer LPI is desirable based on crossing distances and sightlines. As the motor vehicle signal is still red, a LPI allows people walking across the street to establish their presence in the crosswalk before the turning vehicles move. LPIs reduce conflicts between pedestrians and vehicles and improve the visibility of pedestrians in the crosswalk.

LPI phasing shall be the default for pedestrian crossings that require push button activation. If a crossing is set to recall, LPI phasing could cause unnecessary wait time for drivers. LPI with recall should only be used in heavy pedestrian areas where pedestrians are crossing at the majority of signal cycles. To manage limited resources for retrofitting of existing signals, adding LPIs can be prioritized using these factors: crash history, pedestrian crossing volumes, vulnerable populations, one-way streets and T intersections, and intersection visibility.

Right turn on red restrictions can be considered in association with LPIs to better control conflicts with permissive right-turning vehicles. A right turn on red restriction prohibits drivers from turning right when the traffic signal is red. This prohibition eliminates conflicts between right-turning vehicles and people walking across the street in front of them.

Restrictions of right turns on red is the preferred treatment where motor vehicles turn right across crosswalks. As noted in the County's Complete Streets policy, "Motor vehicle speed, flow, and driver convenience shall not be prioritized over safety for vulnerable street users."

#### 4. Midblock crossings

Studies to evaluate midblock crossings, including potential medians, are discussed in Section 5.2.C.1. This section provides geometric design guidance for those crossings.

Raised center median islands can serve as a refuge for people walking or bicycling across the street. This is beneficial not only to reduce the exposure of people walking and bicycling to motor vehicle traffic, but to allow them to cross one direction of motor vehicle travel at a time.

When provided, a minimum median width of 6 feet shall be provided to serve as a refuge at a midblock crossing. A width of 8 feet is preferred, with 10 feet to be provided for trail crossings or where bicycles with trailers may be present. A median island should be included wherever space permits an island with a 10 foot width. Section 2.2.E.10.c.1 provides additional design guidance.

It is preferable to maintain the walking and bicycling passage through the island at the same level as the street. Where the midblock crossing solely accommodates a pedestrian movement, a minimum 5 foot wide travel path shall be provided. Midblock crossings used by bicyclists and pedestrians should provide a minimum 10 foot wide travel path; where a shared use path which will use the median refuge is wider than 10 feet, it is preferred that the minimum width of the travel path match the corresponding shared use path width. If the width of the island allows, the passage should be at a 60-degree angle to the centerline of the street, directing people walking and bicycling to look toward oncoming motor vehicle traffic. This arrangement encourages eye contact between street users, increasing the likelihood that approaching drivers will stop.

A minimum width of 12 feet shall be provided for each direction of travel on each side of the median, measured from curb face to curb face. When islands are located at or near intersections, evaluate the movements of design and control vehicles as described in Section 2.1.C.3. Where bicycle facilities are provided on the street but cannot be accommodated at the midblock crossing, consideration should be given to rerouting the bike lane outside the curb through a bicycle transition to the shared use facility (See Section 2.2.D.3) rather than requiring people to bicycle in the travel lane. Crosswalks at midblock crossings shall have pavement markings and signs. A detail for a midblock crossing pedestrian refuge is provided in Volume IV.

When a midblock crossing traverses more than one travel lane in each direction, advance markings should be provided to stop vehicles prior to the crosswalk such that pedestrians in the crosswalk are more visible to traffic approaching in the adjacent lane, as shown in Figure X-XX.

Figure 2-30. Examples of Yield Lines at Unsignalized Midblock Crosswalks.

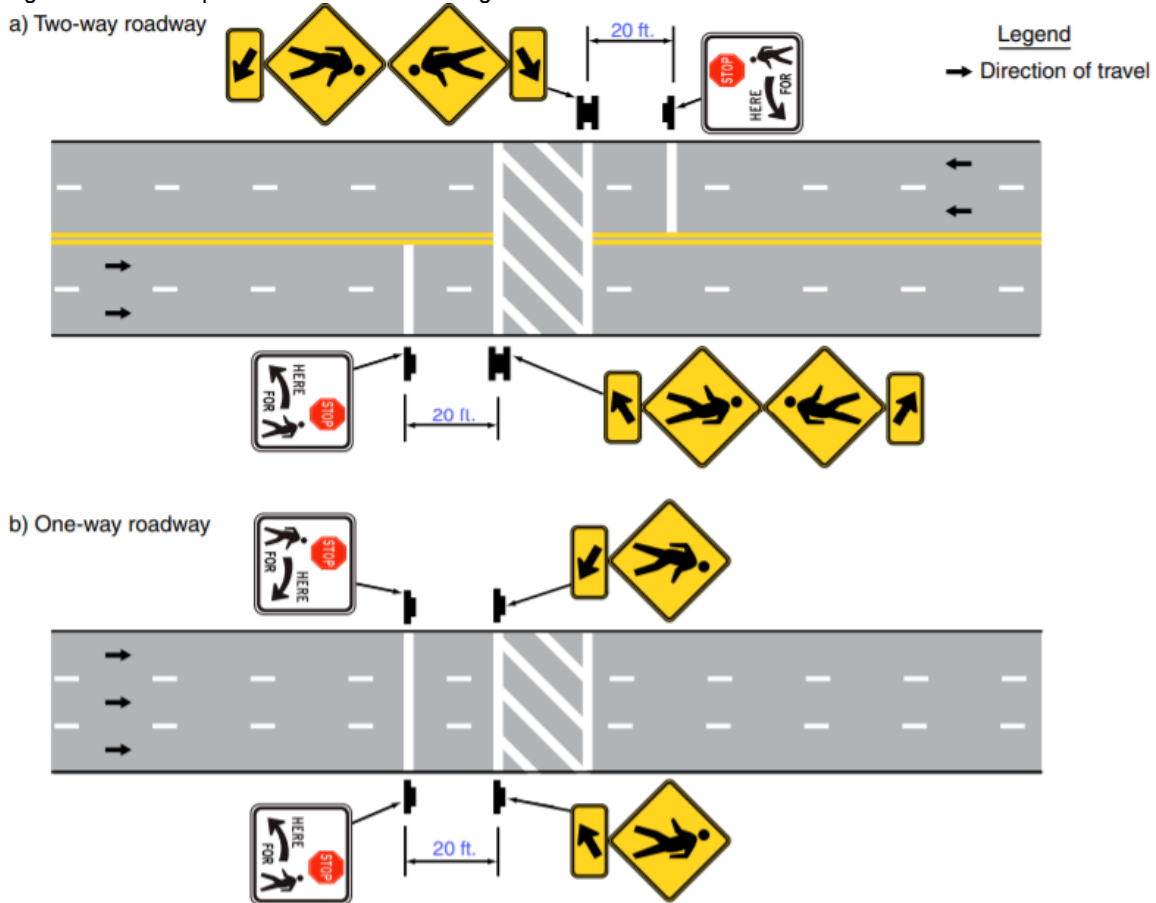

Source: *Maryland Manual on Uniform Traffic Control Devices (2009)*

The visibility of midblock crossings can be improved by providing signalization in accordance with FHWA’s “Guide for Improving Pedestrian Safety at Uncontrolled Crossing Locations” (Ref. 22).

Crosswalk illumination shall be provided at all midblock or uncontrolled approach crosswalks as specified in Section 2.7, Street Lighting.

5. Uncontrolled crossings

As noted in Section 2.4.E.1, crosswalks exist at any intersections where sidewalks or shared use paths are present. Where there is no traffic control device (signal or STOP) sign across the main street, these crosswalks are considered uncontrolled crossings. Even if no crosswalk markings are present, a legal crosswalk exists, so the Designer must take steps to maximize the safety of people walking or bicycling across the street in these circumstances.

Depending on motor vehicle volumes, crossing volumes, speed, and site conditions, simple provision of crosswalk markings at an uncontrolled crossing may not result in motor vehicle drivers reliably stopping for people crossing the street, even though they are legally required to do so. The need for traffic control such as markings, signs, or hazard identification beacons (HIBs) shall be analyzed using the method in FHWA’s “Guide for Improving Safety at Uncontrolled Crossing Locations” (2018) (Ref. 22). A traffic study may be performed to determine whether a full traffic signal may be warranted per MdMUTCD Chapter 4C.

## 6. Geometric design treatments

Many of the speed management measures described in Section 2.2.D.10 also provide benefits for people walking across the street at intersections. These treatments include raised center median islands, curb extensions, speed hump/raised crosswalks, and raised intersections. Mountable truck aprons referenced in Sections 2.2.D.10 and 2.4.B.7 are also beneficial to people walking, as they can reduce the speeds of turning motor vehicles; however, truck aprons are required to remain outside the defined path of travel of pedestrians and bicyclists such that the area of the truck apron is clearly reserved for the exclusive use of large vehicles.

At certain unsignalized intersections, design of a raised crosswalk across the low-volume minor leg of the intersection may be appropriate for certain street types. In this situation, the grade of the sidewalk, separated bike lane, or shared use path remains continuous across the raised crosswalk, with the profile of the minor leg of the roadway rising to meet the crosswalk elevations. This treatment may be desirable in mixed-use districts along sidewalks, shared use paths, and separated bike lanes where pedestrian and bicycle activity is expected to be frequent; for instance, where an Alley intersects a Town Center Street, Town Center Connector, or Boulevard; or, where a shared-use path crosses commercial driveways or low-volume streets. The motor vehicle speeds on the major roadway should be considered when evaluating use of a raised crosswalk to consider additional time that may be needed for a vehicle departing the minor leg of the intersection to maneuver into the major roadway, and additional time that a vehicle turning left from the major street across the raised crosswalk may require to make the maneuver as it slows to cross the raised crosswalk. Raised crosswalks should only be installed where the approach to the intersection on the minor street is relatively flat. Profile considerations for the raised crosswalk can be found in Section 2.5.H and design must consider provisions to provide positive drainage on both sides of the raised crosswalk.

Another geometric design treatment that can reduce the speeds of left-turning motor vehicles is centerline hardening. As shown in Figure 2-31, centerline hardening consists of a low mountable curb along the center of a street on an intersection approach. Functioning much the same way as a truck apron, centerline hardening requires turning passenger cars and other smaller vehicles to make a relatively sharp turn to avoid passing over the curb, thereby reducing turning speeds. Larger vehicles may pass directly over the curb.

Centerline hardening may be considered in areas where a high number of conflicts/crashes occur between left-turning motor vehicles and people walking across the street.

Figure 2-31. Centerline Hardening.

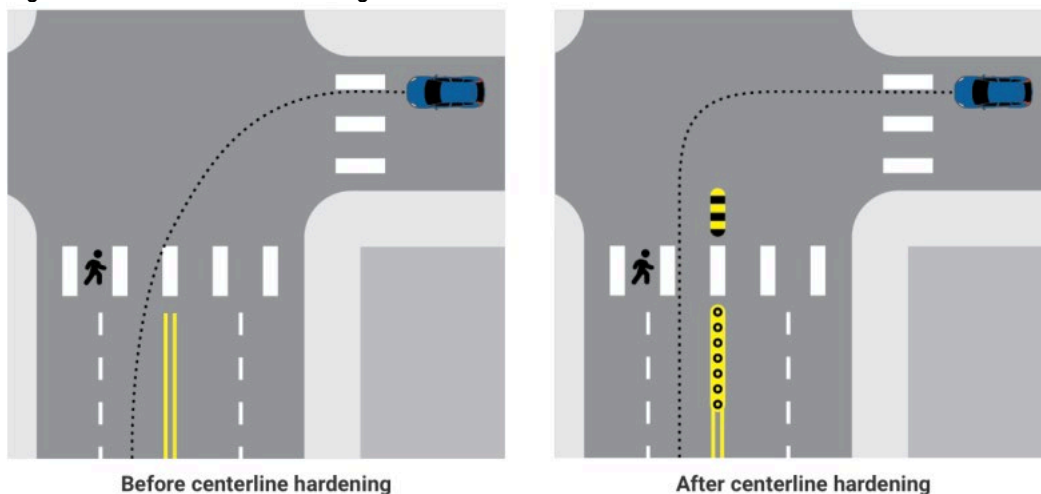

Source: Modified from the Insurance Institute for Highway Safety



## **F. Shared Use Paths at Intersections**

Refer to Section 2.4.G.2, Two-Way Separated Bike Lanes for guidance on shared use paths at intersections. Additional guidance is provided in the AASHTO "Bike Guide" (Ref. 7).

Guidance on geometric design treatments at intersections, including raised crosswalks, is provided in Section 2.4.E.6.

For guidance on shared use path crossings midblock, see Section 2.4.E.3.d.

## G. Bicycle Facilities at Intersections

The primary principle for design of bicycle facilities at intersections is to minimize the exposure of people bicycling to motor vehicle traffic. Figure 2-32 illustrates a variety of intersection types and their relative safety and comfort for people bicycling.

Figure 2-32. Comparison of Bicyclist Comfort and Safety at Intersections.

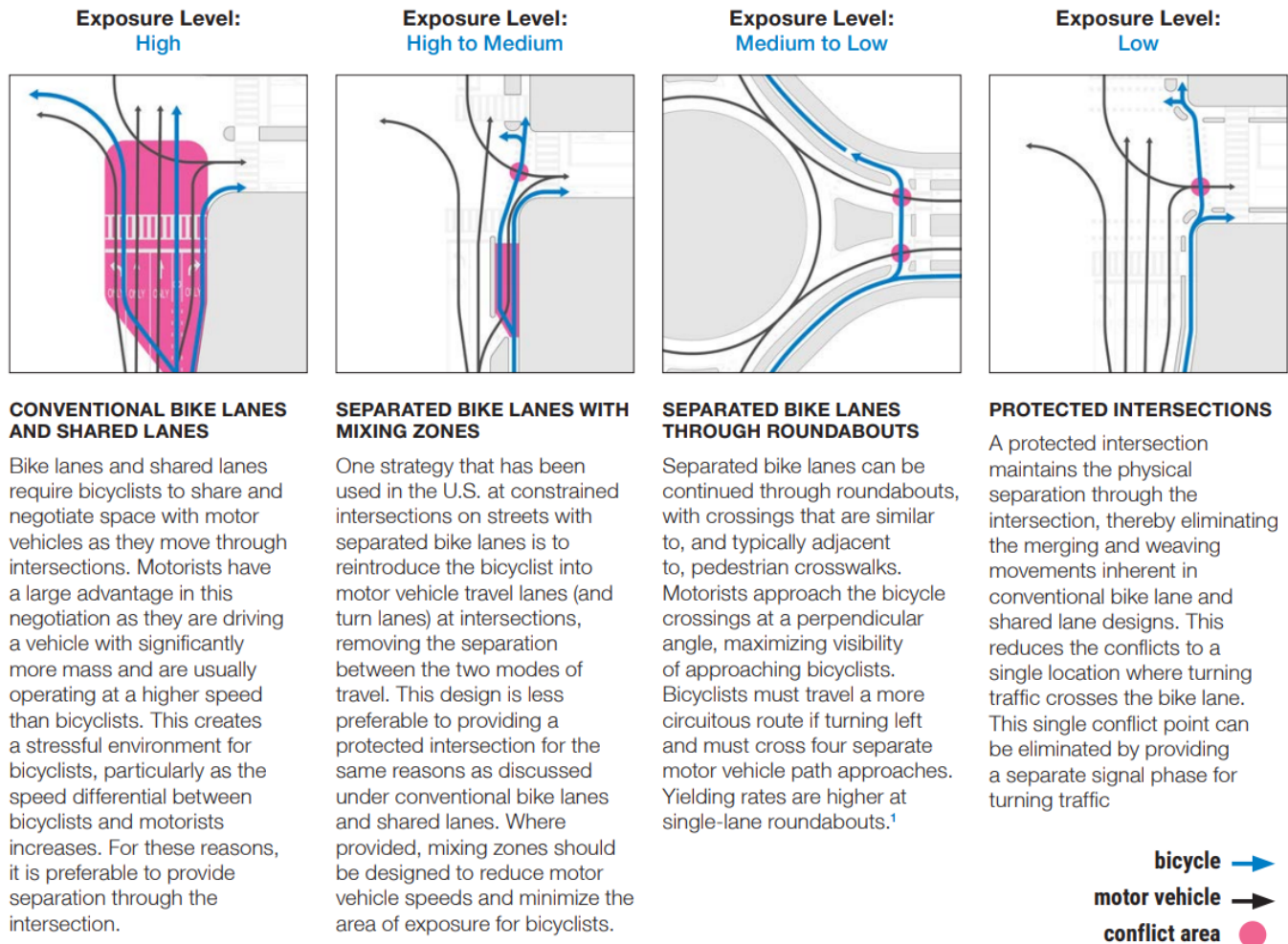

**CONVENTIONAL BIKE LANES AND SHARED LANES**

Bike lanes and shared lanes require bicyclists to share and negotiate space with motor vehicles as they move through intersections. Motorists have a large advantage in this negotiation as they are driving a vehicle with significantly more mass and are usually operating at a higher speed than bicyclists. This creates a stressful environment for bicyclists, particularly as the speed differential between bicyclists and motorists increases. For these reasons, it is preferable to provide separation through the intersection.

**SEPARATED BIKE LANES WITH MIXING ZONES**

One strategy that has been used in the U.S. at constrained intersections on streets with separated bike lanes is to reintroduce the bicyclist into motor vehicle travel lanes (and turn lanes) at intersections, removing the separation between the two modes of travel. This design is less preferable to providing a protected intersection for the same reasons as discussed under conventional bike lanes and shared lanes. Where provided, mixing zones should be designed to reduce motor vehicle speeds and minimize the area of exposure for bicyclists.

**SEPARATED BIKE LANES THROUGH ROUNDABOUTS**

Separated bike lanes can be continued through roundabouts, with crossings that are similar to, and typically adjacent to, pedestrian crosswalks. Motorists approach the bicycle crossings at a perpendicular angle, maximizing visibility of approaching bicyclists. Bicyclists must travel a more circuitous route if turning left and must cross four separate motor vehicle path approaches. Yielding rates are higher at single-lane roundabouts.<sup>1</sup>

**PROTECTED INTERSECTIONS**

A protected intersection maintains the physical separation through the intersection, thereby eliminating the merging and weaving movements inherent in conventional bike lane and shared lane designs. This reduces the conflicts to a single location where turning traffic crosses the bike lane. This single conflict point can be eliminated by providing a separate signal phase for turning traffic

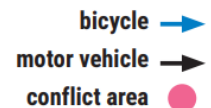

Source: “Separated Bike Lane Planning and Design Guide, Chapter 4 Intersection Design” Massachusetts Department of Transportation (Ref. 23)

Bicycle accommodation should not be interrupted by intersections. The Designer is referred to the FHWA “Bikeway Selection Guide” and NACTO’s “Don’t Give Up at the Intersection” for specific intersection considerations (Ref. 11, Ref. 24). The following guidance for intersection treatments for each of the bicycle facility types described in Section 2.2.D.1 is quoted from the “Bikeway Selection Guide.”

### 1. One-Way Separated Bike Lanes

Intersection designs should promote visibility of bicyclists and raise awareness of potential conflicts. The provision of sufficient sight distance is particularly important at locations where the on-street parking is located between the bike lane and travel lane. One-way separated bike lanes may transition to shared lanes, bike lanes, mixing zones, or protected intersections.

Intersection approaches with mixing zones require motorists to yield to bicyclists before entering or crossing the bike lane. This clarity can be further enhanced with bicycle lane extensions through the intersections, green colored pavement, and regulatory signs. Research shows protected intersections have fewer conflicts and are therefore preferable.

Design transitions to be clear to bicyclists and motorists.

### 2. Two-Way Separated Bike Lanes

Care should be taken at intersections and driveways which intersect two-way separated bike lanes and shared use paths that run parallel to the street due to the two-way operation of bicycles in these locations. Crash patterns consistently show contra-flow movement of bicyclists are a main factor in crashes due to motorists failing to yield or look for approaching bicyclists. Where two-way separated bike lanes are implemented on one-way streets, siting these facilities to the right of automobile lanes has resulted in safer intersections for bicyclists by reducing conflicts. All intersections should be designed with protected intersections due to the two-way operation; transitions to other bikeway types should occur after the intersection.

To mitigate these conflicts, research suggests the following potential solutions:

- The application of separate phases at signals with high volumes of turning motorists
- Slow turning drivers with reduced corner radii or raised crossings
- Improve sight lines
- Raise awareness with marked crossings and regulatory signs

For more information, see the FHWA “Separated Bike Lane Planning and Design Guide” (Ref. 13).

### 3. Buffered Bike Lanes and Conventional Bike Lanes

Intersection approaches with bike lanes require motorists to yield to bicyclists within the bike lane before entering or crossing the bike lane. This clarity can be further enhanced with bicycle lane extensions through the intersections, green colored pavement, and regulatory signs. Bike lanes may also transition to shared lanes or one-way separated bike lanes.

Additional details about bike lane treatment through intersections is provided below.

a. Through bike lanes

Through bike lanes, also known as pocket lanes, are marked bike lanes that provide the bicyclist with guidance on how to position themselves to avoid conflicts with turning vehicles at an intersection. They also alert motorists to the presence of bicycle traffic. Through bike lanes are most commonly placed to the left of right turn lanes.

Design guidance for through bike lanes is provided by the AASHTO “Bike Guide” and the NACTO “Urban Bikeway Design Guide” (Ref. 7, Ref. 12).

Figure 2-33. Through bike lane diagram.

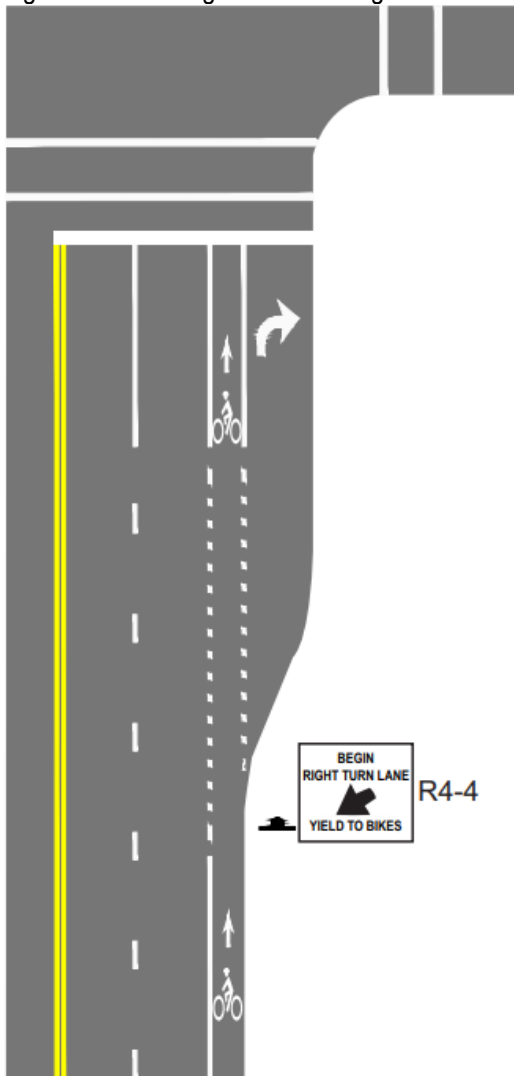

Note: Use of sign is optional.

Source: AASHTO “Bike Guide” (Ref. 7)

b. Combined bike lane/turn lane

A combined bike lane/turn lane can be used at intersection approaches where there is not sufficient space to maintain a through bike lane adjacent to the turning lane. This treatment “places a suggested bike lane within the inside portion of a dedicated motor vehicle turn lane.” A conventional bicycle marking with a dashed line, as shown in Figure 2-34, is used to delineate space for the cyclist and the motorist and indicate the intended path for through bicyclists. It also makes clear to both the bicyclist and the motorist that whoever arrives first has the right of way.

The minimum width for the bicycle area is 4 feet. The bicycle area should be marked with MUTCD 9C-3B, “helmeted bicycle symbol” with the arrow as the bike lane marking. The width of the combined lane, not including gutter, should be a minimum of 10.5 feet and a maximum of 14 feet. If 15 feet is available for the right turn only lane, then a full bicycle through lane can be accommodated. If 10.5 feet cannot be provided, use of a narrower lane with modified symbol dimensions can be used with the approval of the Department of Public Works.

Figure 2-34. Combined Bike Lane/Turn Lane.



Source: NACTO “Urban Bikeway Design Guide” (Ref. 12)

## c. Bicycle box

Paired with a bike lane, a bicycle box is designed to provide bicyclists with a way to get ahead of queuing motor vehicle traffic at a signalized intersection during the red signal phase. The bicycle box is a designated space at the head of the traffic lane. According to the Interim Approval for Optional Use of an Intersection Bicycle Box (IA-18) from the FHWA (Ref. 25), bicycle boxes provide numerous operational benefits including:

- Reduction in the number of conflicts between bicyclists and turning drivers at the study intersections
- Reductions in the number of avoidance maneuvers by both bicyclists and motorists
- Reductions in the number of bicycle and motor vehicles encroaching into pedestrian crosswalks when stopped at an intersection

It should be noted that use of treatments which have a FHWA Interim Approval require state and federal approval. In order to use the bicycle box, approval should be obtained through MDOT SHA according to Section 1A.10 of the MdMUTCD (Ref. 10).

Design guidance for bicycle boxes is provided by the “Interim Approval,” the FHWA “Separated Bike Lane Planning and Design Guide,” and the NACTO “Urban Bikeway Design Guide” (Ref. 25, Ref. 13, Ref. 12).

Figure 2-35. Bicycle Box diagram.

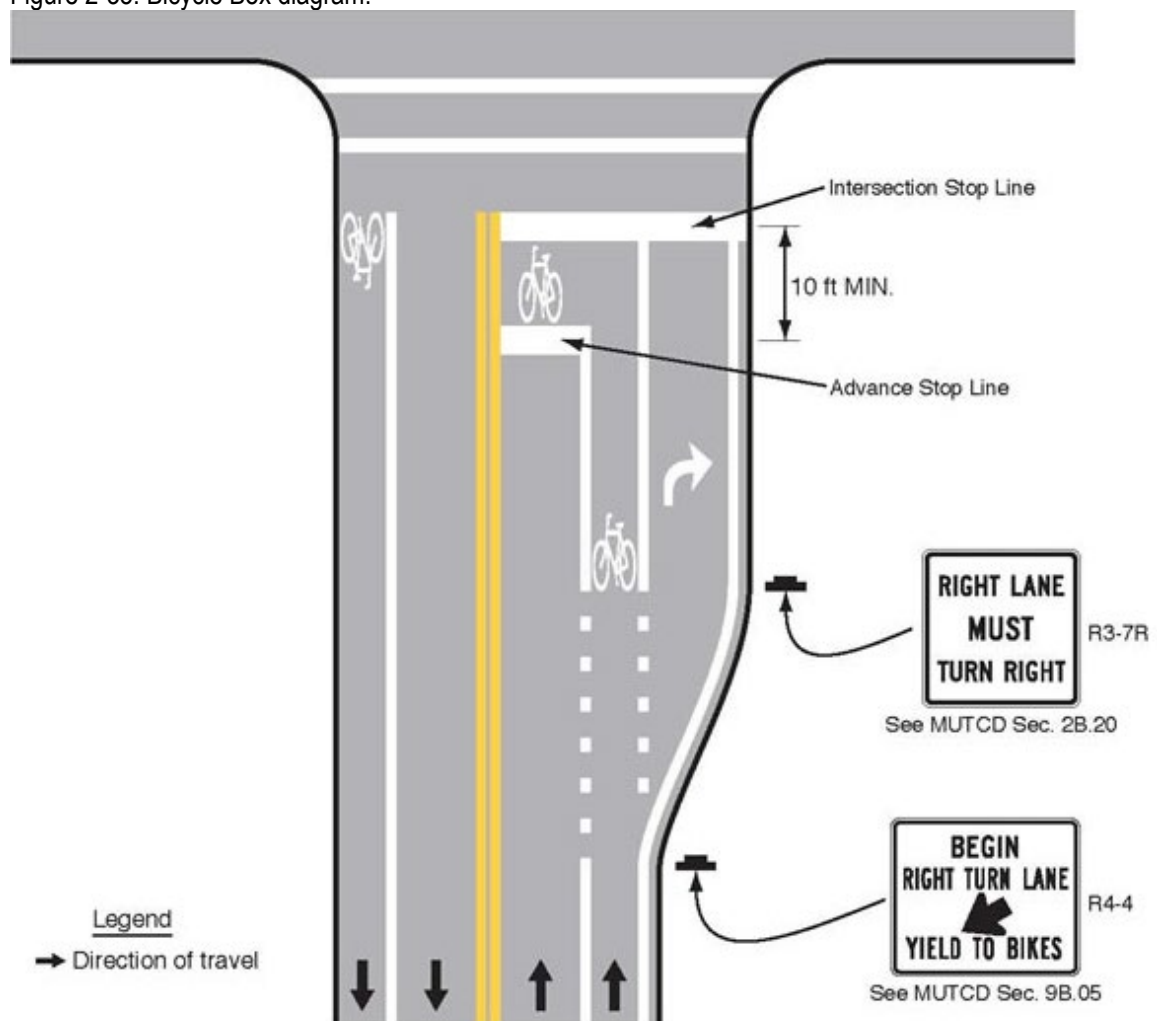

Source: FHWA Interim Approval for Optional Use of an Intersection Bicycle Box (IA-18)



d. Two-stage turn queue boxes

A two-stage turn queue box provides bicyclists a safe way to make a left turn at a multi-lane signalized intersection. It is a designated area for bicyclists to queue to turn that is located outside the path of motor vehicle traffic and through bicyclists. To use a two-stage turn queue box, a bicyclist would proceed on a green signal indication to the box on the right side of the travel lane, turn left within the box, and wait for a green signal to cross the street, completing the left turn in two stages.

It should be noted that use of treatments which have a FHWA Interim Approval require state and federal approval. In order to use the two-stage turn queue box, approval should be obtained through MDOT SHA according to Section 1A.10 of the MdMUTCD (Ref. 10).

Design guidance for bicycle boxes is provided by the “Interim Approval for Optional Use of Two-Stage Bicycle Turn Boxes (IA-20)” and the NACTO “Urban Bikeway Design Guide” (Ref. 26, Ref. 12).

Figure 2-36. Two-stage turn queue box diagram.

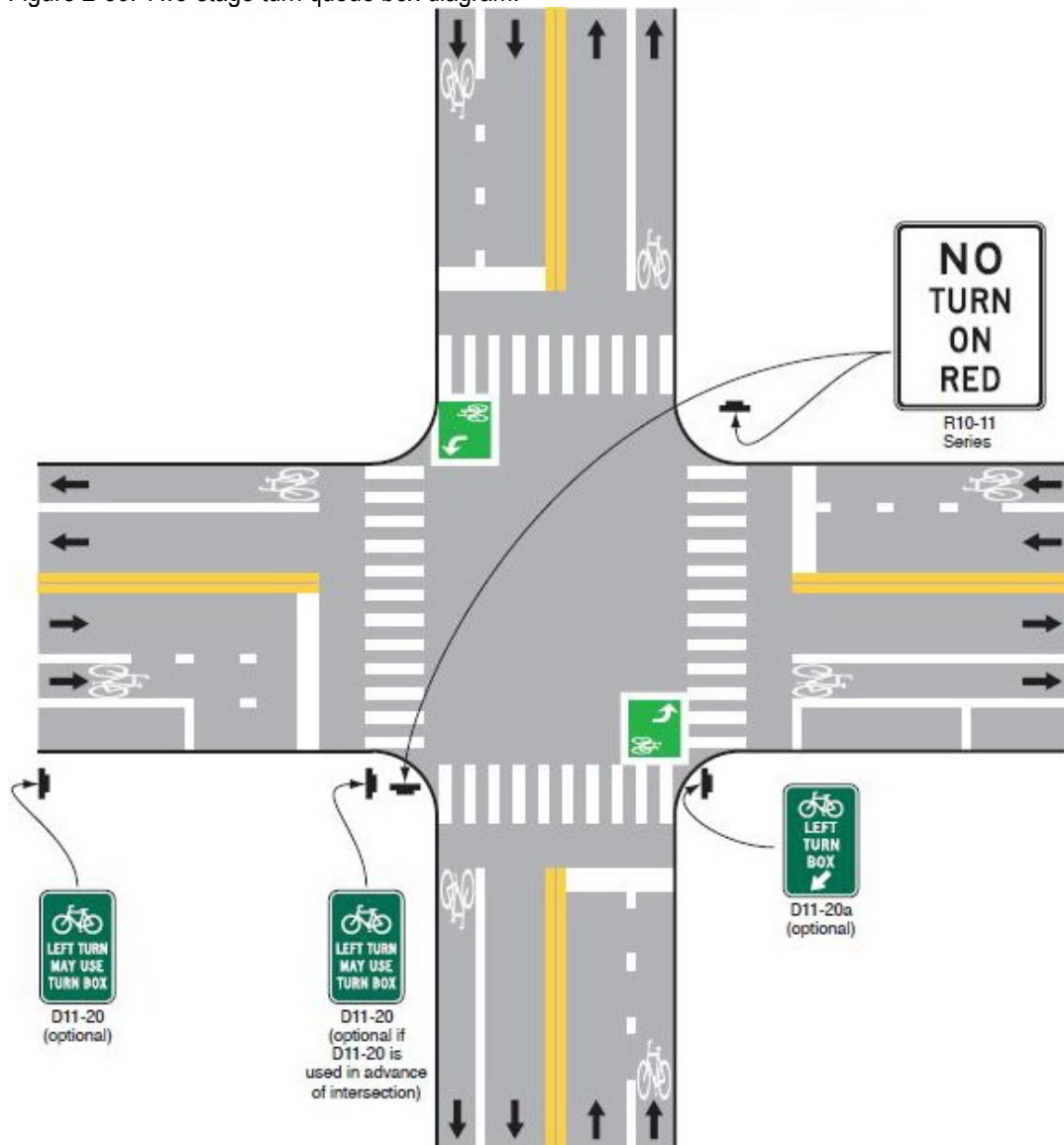

Source: FHWA Interim Approval for Optional Use of Two-Stage Bicycle Turn Boxes (IA-20) (Ref. 26)

e. Side street crossings

Bicycle lane extensions and/or green colored pavement shall be used to extend bike lane markings across side streets. Bike lane markings across side streets will be conspicuous by continuing as dashed lines across the side street. An example is shown in Figure 2-37.

Figure 2-37. Bike Lane Markings Across Side Streets.

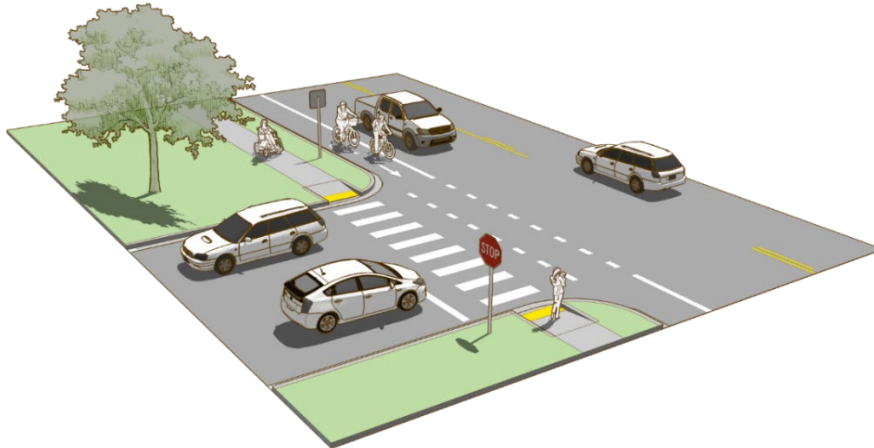

Source: “Small Town and Rural Multimodal Networks,” FHWA (Ref. 27)

f. Conflict Zones

Where special emphasis is desired, green pavement color may be used within bike lanes and at merging or weaving areas where motor vehicles may cross bike lanes. This treatment can be used where known conflicts exist or are expected, such as at commercial driveways and between a bike lane and a right turn lane. Material specifications shall be slip resistant, and shall be approved by the Department of Public Works. Design guidance for green pavement color is provided by the “Interim Approval for Optional Use of Green Colored Pavement for Bike Lanes (IA-14)” (Ref. 28).

For more guidance on pavement markings at driveways, see Section 2.5.I.

Figure 2-38. Application of Green Pavement Color in Conflict Zones.



Source: NACTO

#### 4. Shoulders

On intersection approaches with shoulders, the shoulder will typically taper to the intersection, implying shared street condition, or transition to a bike lane design to signify that turning and crossing motorists should yield. Shoulders may also transition to one-way separated bike lanes.

#### 5. Bicycle Boulevards

Continuity and priority access for bicyclists is important to the success of bicycle boulevards. A key aspect of bicycle boulevard design is to ensure comfortable and safe crossings of intersecting streets so that travel along the bicycle boulevard can be maintained. On most bicycle boulevards, bicyclists are likely to approach intersections in shared lanes. Due to the lower volume and operating speeds associated with bicycle boulevards, shared lane approaches are likely to have good performance characteristics when crossing another low-speed, low-volume street. At approaches to higher speed and volume streets, many bicycle boulevards transition to bike lanes, separated bike lanes, or shared use paths. At signalized intersections, bicyclists should be detectable or able to call a red signal via push button. A bike box can provide priority for bicyclists at signalized crossings (see Section 2.4.G.3.c). Maintaining a continuous bicycle boulevard may also require creating a bicycle-only cut through at a median, or use of a Hazard Identification Beacon (HIB). Additional guidance on safety provisions at uncontrolled locations is provided in Section 5.2.C.1

#### 6. Shared Lanes

Bicyclists are exposed to all crash types within shared lanes at intersections. The lack of a bikeway can reduce the predictability of a bicyclist's operating location. This can be exacerbated in locations where bicyclists operate in the wrong direction or on adjacent sidewalks to avoid uncomfortable traffic conditions.

Shared lane markings, also known as sharrows, and signage should be used to provide bicyclists with guidance on where they should be located within the lane to maintain good visibility with surrounding vehicles and to trigger a signal change where applicable. For larger intersections, a transition can be provided to allow the bicyclist to move from the roadway to an adjacent sidewalk, and traverse the intersection using the sidewalk and crosswalk facilities. For further guidance on sharrow placement, see Section 2.2.D.1.g. Guidance on bicycle facility transitions are provided in Section 2.2.D.3.

#### 7. Traffic Signal Considerations for Bicycling

Multiple signal control options exist for bicyclists approaching intersections. Signal treatments along a street or corridor should be kept consistent so that they are clear to all users of the street.

##### a. Shared lanes, conventional bike lanes, and one-way separated bike lanes

Bicyclists traveling in shared lanes, conventional bike lanes, and one-way separated bike lanes shall follow roadway traffic control devices including traffic signals and stop signs.

Traffic signals should be timed to ensure that bicyclists have adequate time to traverse the intersection during the green phase. The bicycle clearance interval should accommodate 85 percent of bicyclists at their normal bicycling speed, which is consistent with MUTCD guidance on pedestrian clearance intervals. If possible, bicycle speeds should be measured in the field to determine speeds given local conditions. If approaches are level, 7.5 mph can be used as a default speed (Ref. 12).

Bicycle detection should be provided at signalized intersections where on-road bicycle facilities are present. Automated detection, such as an induction loop or video detection, should be highlighted by a symbol on the pavement indicating the optimum position for a bicyclist (MdMUTCD Figure 9C-7). Per the MdMUTCD, a R10-22 sign may be installed to supplement the pavement markings (Ref. 10).

- b. Two-way bike lanes and shared use paths  
Where bicyclists are traveling in two-way separated bike lanes or on a shared use path, they may be subject to following pedestrian signals. In these cases, a BIKES USE PED SIGNAL sign (R9-5) shall be placed adjacent to the pedestrian signal head.
- c. Bicycle signals  
MUTCD “Interim Approval for Optional Use of a Bicycle Signal Face (IA-16)” governs the use of bicycle signals (Ref. 29). The Interim Approval indicates that bicycle signals may be used in the following situations:
- Bicyclist non-compliance with the previous traffic control
  - A leading or lagging bicycle interval
  - Continuing the bicycle lane on the right-hand side of an exclusive turn lane that would otherwise be in non-compliance with Paragraph 6 of Section 9C.04
  - Augmentation of the design of a segregated counter-flow bicycle facility
  - Provision of an increased level of safety by facilitating unusual or unexpected arrangements of the bicycle movement through complex intersections, conflict areas, or signal control

It should be noted that use of treatments which have a FHWA Interim Approval require state and federal approval. In order to use the bicycle signal face, approval should be obtained through MDOT SHA according to Section 1A.10 of the MdMUTCD (Ref. 10).

Bicycle signals may take one of two forms:

- i. A conventional signal head accompanied by a BICYCLE SIGNAL sign (R10-10b as shown in the Interim Approval), which is intended for the exclusive use of bicyclists.
- ii. Bicycle signal faces, which contain a bicycle symbol within the illuminated signal face. Bicycle signal faces may be used where no motor vehicle moves conflict with the signalized bicycle movement. To implement bicycle signal faces, an approved Request to Experiment is required as detailed in Section 1A.10 of the MdMUTCD (Ref. 10). This process is through MDOT SHA.

## H. Transit Facilities at Intersections

Refer to the Maryland Department of Transportation Maryland Transit Administration (MDOT MTA) “Bus Stop Design Guide” for the design of bus stops (Ref. 30).

## I. Right-of-Way

The right-of-way lines at intersections shall be adequate to accommodate all the required design features. All design features to be owned or maintained by the County must be within right-of-way or easements such that the County is granted sufficient access to perform maintenance. The distance between the edge of sidewalk or shared use path and the right-of-way that encompasses it within the intersection shall be no less than the same dimension provided along the streets which comprise the intersection.

## J. Major Intersection Design Procedures

### 1. General

The following procedure is intended to be used as a guide for the design of major intersections. It provides a framework within which the traffic and geometric design elements, as well as any other pertinent factors, can be studied in an orderly fashion.

The major steps are:

- a. Collection of data
- b. Establishment of applicable design criteria
- c. Traffic studies
- d. Development of alternatives
- e. Selection of optimum plan
- f. Final design

### 2. Collection of Data

#### a. Traffic Data

The types of multimodal traffic data required, and the methods by which they are to be obtained are included in Chapter 5.

#### b. Existing Physical Conditions

Existing field run topography, street conditions, utilities and right-of-way limits should be shown on an up-to-date map of the site. Information regarding flood levels, drainage problems, and soil conditions should also be obtained. Any buildings, walls, or other features that might conflict with the proposed intersection should be carefully noted on the plan.

#### c. Future Highway and Land Development

The Department of Planning and Zoning, the Department of Public Works, and the MDOT State Highway Administration (MDOT SHA) should be contacted to determine what land development is planned for the area as well as any planned street or utility improvements.

### 3. Establishment of Applicable Design Criteria

Prior to the development and analysis of various layouts, certain design criteria must be established to assure all alternatives are designed on the same basis. The Street Types detailed in Section 1.3.C are to be used as a guide for design, however, specific design hour volumes shall be used for the actual roadway design, right-of-way and pavement width. These design criteria shall include:

- a. Design year and ultimate projected traffic volumes
- b. Target speed and design speed of each intersecting street
- c. Safety of vulnerable users
- d. Acceptable level of service
- e. Design vehicle and control vehicle
- f. Design speed of turning movements
- g. Special features (such as need to accommodate people with disabilities or provisions for bus stops)

#### 4. Multimodal Traffic Studies

The multimodal traffic studies required and the methods by which they are to be conducted are presented in Chapter 5.

#### **K. Minor Intersection Design Procedures**

All intersections not requiring a level of service analysis as indicated in Chapter 5 are considered to be minor intersections. They are the intersection of Access Place or Access Street and any other street, and the intersection of two minor collectors or streets whose projected volumes do not exceed 3,000 ADT on each street. All others are considered to be major intersections.

The design procedure for minor intersections is similar to that for major intersections but with some modifications. No level of service analysis is required because continuation of the typical section through the intersection will ensure adequate traffic operation. Fewer alternatives will have to be developed than for major intersections because volumes will be lower and channelization and turning roadways will seldom be warranted.

The same elements of geometric design and evaluation of alternate designs that apply to major intersections also apply to minor intersections.

#### **L. Intersections with State Highways**

Criteria for design and information related to acquisition of permits for intersections with State Highways are contained in "Rules and Regulations for Commercial, Subdivision, Industrial, and Residential Entrances to State Highways."

Information regarding traffic signals at intersections with State Highways is included in Chapter 5.

#### **M. Intersections with Existing Streets**

A sight distance analysis shall be required for intersecting streets with existing streets and for proposed driveways access to existing streets. See Section 2.1.E.



## 2.5 Driveways

### A. General

Control of driveway location and design is essential in assuring that a street will be capable of performing its intended role through and even beyond the design year. Driveways must be so located as to minimize impact on traffic flow and still provide access consistent with the street's classification and projected volumes.

The control of access shall be in accordance with the functional classification of the street and refined traffic studies.

There are three types of driveways: residential, commercial and industrial, and high volume. Residential and use-in-common driveways are those serving single-family houses with no more than six dwelling units. Commercial and industrial driveways serve primarily employment and shopping areas, and are consequently used by more trucks and larger number of vehicles than residential driveways. High volume driveways are those with anticipated volumes exceeding 200 peak hour vehicles (total volume for both directions for a two-way entrance or the total volume for a one-way entrance).

The design of residential driveways and commercial and industrial driveways is discussed herein. High volume driveways shall be designed in accordance with intersection design criteria.

High volume driveways must be analyzed in the same manner as roadways. Depending on the movements that the high-volume driveway supports (i.e., 1-way or 2-way) the analysis may require an examination of queuing acceleration/deceleration criteria, level of service, signal warrants or all of these factors.

### B. Residential

The desired width of residential driveways and easements, when required, is as shown in Table 2-23.

**TABLE 2-23  
REQUIRED MINIMUM DRIVEWAY WIDTHS**

Lots Served	Driveway Width (ft)	Corresponding Easement (min) (ft)
1	12	N/A
2 to 6	16	24*

\*If a shared residential driveway crosses a 100-year floodplain as defined by Volume 1 of the Howard County Design Manual, then a Public Access Place shall be required.

Residential driveway entrances shall be in accordance with the Standard Details, Volume IV.

Driveways serving one residential lot or shared driveways for up to six lots shall consist of a minimum standard of six inches of crusher run base with tar and chip coating. All others refer to the Standard Details, Volume IV.

Drainage elements (e.g. culverts, bridges) shall be provided at all driveways where the waterway discharge meets or exceeds 5 cubic feet per second for a 10-year storm. The drainage element within a 100-year floodplain shall be designed to pass the 100-year storm with no more than 1 foot of water over the driveway.

**C. Commercial – Industrial and Multi-family**

Entrance openings and curb radii shall be in accordance with the Standard Details, Volume IV. The angle of intersection shall be radial or 90 degrees unless otherwise approved by the Department of Public Works or Department of Planning and Zoning.

Commercial entrances shall be designed for WB-40 vehicles at a minimum and be constructed in accordance with the Standard Details, Volume IV. For commercial entrances that function as intersections, see Section 2.4, Intersection Design.

**D. Spacing and Corner Clearance**

In designing driveways near intersections, the effects on through traffic of vehicles entering and leaving the driveway must be considered. Volumes, flow patterns, signalization, channelization, and sight distance are among the factors involved.

Each driveway shall be designed considering anticipated traffic conditions and the driveway’s effect upon the traffic operation. The clearances shall not be less than shown in the following:

Minimum Corner Clearance

Driveway to Intersection..... Distance

Single Residential ..... 25'

Use in Common Driveway..... 50'

Commercial, Industrial, and Multifamily

Minor Arterial..... 75'

Major Collector..... 75'

Minor Collector..... 50'

Local ..... 50'

High Volume ..... Treated as an Intersecting Street

Note: Driveway clearance measured from edge of driveway entrance or start of depressed curb to the PT of the adjacent, intersecting street

For driveway spacing between driveways of different classifications, the higher spacing of the different categories shall be used.

The normal minimum distance between any driveway and property line shall be 2 feet measured at the right-of-way line. This does not apply to two adjoining driveways serving pipe stem lots.

Distance Required between Driveways

Distance Between Driveways (Min.)

Residential ..... 4\*

Commercial, Industrial, and Multifamily

Minor Arterial..... 350'

Major Collector..... 250'

Minor Collector..... 110'

Local ..... 110'

High Volume ..... Treated as an Intersecting Street

\*Measured between edges of driveways at right-of-way lines.

**E. Sight Distance**

The sight distance shall be provided at all driveways per Section 2.1.E.3. The choice of design vehicle is dependent upon the type of land use to be served by the driveway. Sight distance analysis shall be submitted for all existing driveways that have not been previously studied or that add additional users. If the driveway was previously studied, provide this study with the submission.

**F. Grade**

Maximum grade of single-family residential driveways shall be 15% and minimum turning centerline radius shall be 45 feet. Overhead clearance shall be a minimum of 12 feet. Maximum grade of multi-family residential driveways (travel ways) shall be 12%, and limited to 6% when parking is adjacent thereto.

The grades for commercial and industrial and high-volume multi-family residential driveways (200 vph) shall be a maximum of 10% percent. The vertical and horizontal alignment for these types of driveways shall be designed using a minimum design speed of 25 miles per hour. Overhead clearances shall be a minimum of 16 feet.

Recommended driveway profiles are included in the Standard Details, Volume IV.

**G. Auxiliary Lanes**

An auxiliary lane may be required along minor arterials and major collector streets at high volume driveways (>200 vph) or because of high traffic volumes, unusual conditions or for safety purposes, or related to truck use and the percent and length of grade. Auxiliary lanes should be minimized to the extent possible, as they result in wider streets with faster motor vehicle traffic, leading to conditions that are less comfortable for people walking, bicycling, and accessing transit vehicles.

All auxiliary lanes shall be designed in accordance with Section 2.4.

## H. Sidewalks and Shared Use Paths

Where a sidewalk crosses a driveway or entrance, a 5 foot wide walking pathway with a maximum 2% cross slope shall be provided across the entire driveway width. The preferred treatment for new construction is to maintain a continuous sidewalk or shared use path grade across the driveway, modifying the driveway grade as needed to give visual preference to people walking and bicycling. If required, ADA compliant sidewalk ramps shall be provided prior to the pathway across the driveway or entrance; when ramps are provided, detectable warning surfaces may accompany them. When the sidewalk continues on the same grade without ramps, detectable warning surfaces are not provided. The same provision shall be made for shared use paths, with the entire path width (minimum 10 feet) being maintained with a maximum 2% cross slope across the driveway.

Guidance on geometric design treatments that can be considered at driveways, including raised crosswalks, is provided in Section 2.4.E.6.

Abrupt changes in driveway or entrance grades should be avoided to limit potential vehicle damage and maximize vehicle occupant comfort. Unless limited by right-of-way, residential and commercial driveways should be constructed with vertical curves between grade changes. The maximum grade break between the sidewalk or shared use path and driveway or entrance approach on an upgrade shall be 12% over a 10 foot vertical curve. The maximum grade break between the sidewalk or shared use path and a driveway or entrance on a downgrade shall be 3% over the first 10 foot vertical curve and 8% over 10 foot intervals thereafter. Refer to Figure 2-39 for additional details. The maximum grade on a residential driveway shall be 15% and a commercial driveway shall be 10%. It should be noted that the guidance provided herein may not be sufficient for “low-boy” or similar low-clearance vehicles, and design for those specific vehicles should be considered where applicable. Additional considerations for driveway or entrance profiles include sight distance between vehicles, pedestrians, and cyclists, as well as provision of positive drainage. More guidance on considerations for driveway design can be found in “NCHRP Report 659, Guide for the Geometric Design of Driveways” (Ref. 31).

Figure 2-39. Driveway profile on an upgrade and downgrade

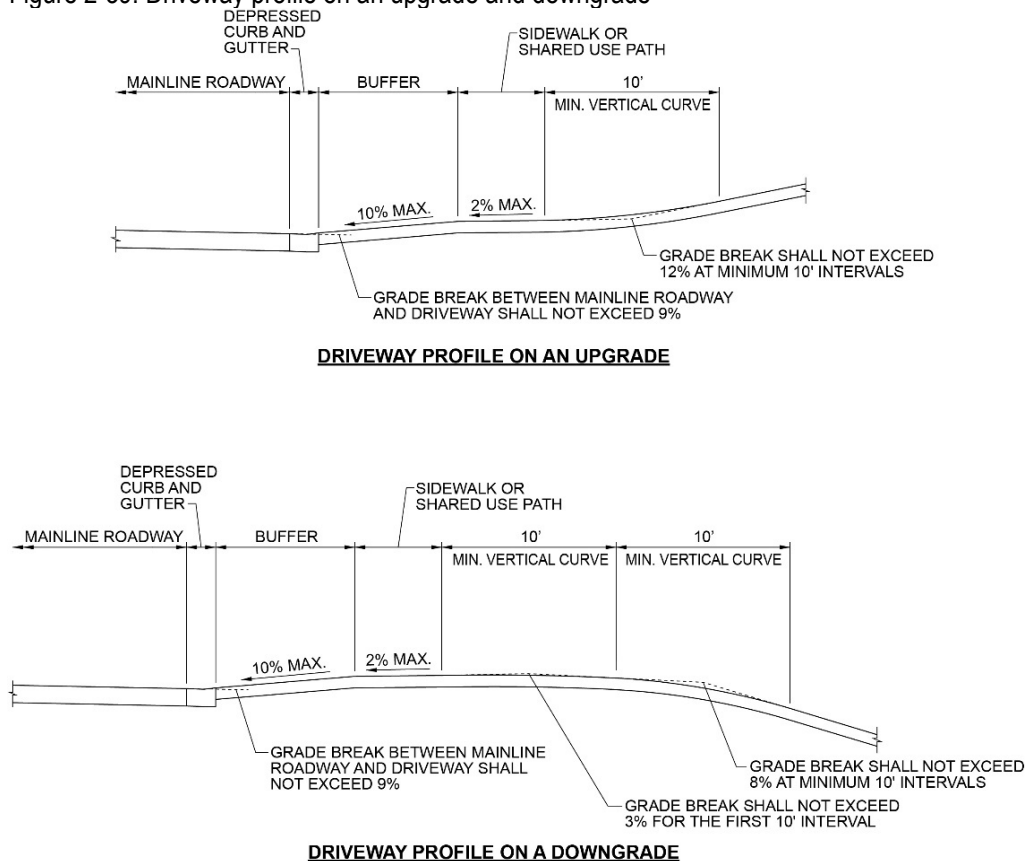

## I. Pavement Markings

Solid edge line pavement markings shall not be continued through major commercial, industrial, retail, and high-density housing driveways (>200vph trips) but may continue across minor single unit residential driveways.

At driveways where high numbers of conflicts are anticipated between people driving and bicycling, bicycle lane extensions and/or green colored pavement shall be used to extend bike lane markings across the driveway as shown in Figure 2-37 and Figure 2-40 may be considered. Although Figure 2-40 shows green colored pavement markings in conjunction with a one-way separated bike lane, this treatment may also be appropriate for a two-way separated bike lane, buffered bike lane, and conventional bike lane. Additional guidance for marking bicycle facilities at driveways are provided in the AASHTO “Bike Guide” and the FHWA “Separated Bikeway Planning and Design Guide” (Ref. 7 and 13).

Figure 2-40. Enhanced Bicycle Pavement Markings at Driveways.

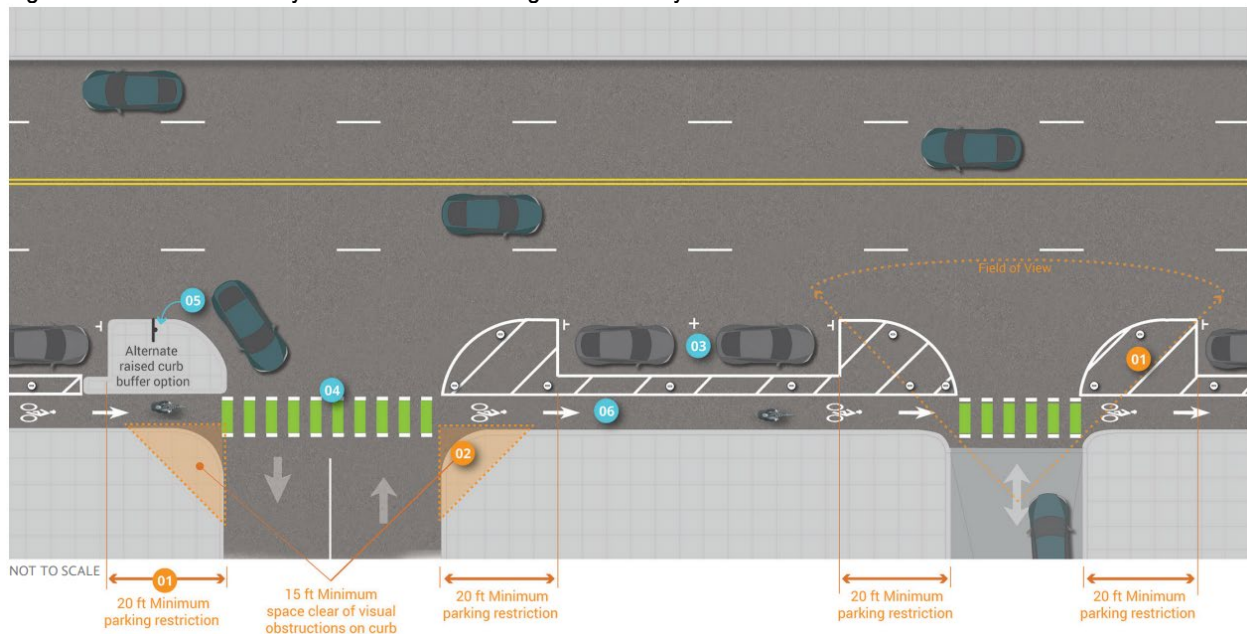

Source: FHWA “Separated Bike Lane Planning and Design Guide” (Ref. 13)

## 2.6 Parking Requirements and Off-Street Parking Lots

### A. General

The need to provide sufficient parking space is critical to the effective use of these design standards. This parking needs to be provided at locations that are consistent with these design standards and the provisions of the Zoning Regulations and the Subdivision and Land Development Regulations.

### B. Residential Parking

The provision of adequate parking space is a function of zoning density, minimum lot size, and the availability of front yard setback areas. These elements should be evaluated to develop the design mix between off-street (i.e., on lot) and on-street parking. Where possible, effort should be made to create side by side driveways on adjacent lots to maximize on-street parking. Parking is not permitted in cul-de-sacs. On street parking may be treated according to Table 2-24.

**TABLE 2-24  
ON STREET PARKING**

Zoning Classification	Average Daily Traffic	Street Type*
SFD: RC, RR	N/A	Rural Development Street
SFD: Other Districts Except R-MH	<2,000	Neighborhood Yield Street 24'
SFD: Other Districts Except R-MH	≥2,000	Neighborhood Yield Street 26'
R-MH, SFA, Apts.	<1,000	Neighborhood Yield Street 26'
R-MH, SFA, Apts.	≥1,000	Neighborhood Yield Street 28'

\*Note: Indented parking is designated on-street parking set back from the curb line. Indented head-in or indented parallel parking may be required to meet the parking requirements described in the Subdivision Regulations. For indented parallel parking use Neighborhood Street 2 with parking. Indented head-in parking should be provided in conjunction with the Neighborhood Yield Street 26' and is only allowed on streets with less than 1,000 ADT. For both types of indented parking, curb extensions consistent with detail R-4.10 in Volume IV shall be used.

Indented on-street parking maintenance and snow removal shall be the responsibility of the private association.

### C. Off-Street Parking Lots

Off-street parking lots must be designed to accommodate the anticipated demand, provide parking stalls of sufficient size to accommodate the vehicles and provide a circulation system that will minimize the delay within the parking lot and prevent overflow congestion onto the adjacent streets. The factors involved in projecting parking demand are discussed in Chapter 5 and the minimum requirements for various land uses are given in the Zoning Regulations. Dimensions of the various components of a parking lot shall be in accordance with current Institute of Transportation Engineers (ITE) guidelines. The basic dimension of a standard size parking stall shall be 9' by 18'. Adjustments to this size can be made for designated compact car parking spaces (8.5' by 16') and other designated parking conditions. See Appendix G, Parking Stall Layout elements for aisle and stall dimensions for various parking arrangements.



The design of a parking lot must be such that sufficient off-street reservoir space is provided to store vehicles waiting to enter the facility. Minimum inbound off-street reservoir requirements are given in Table 2-25.

**TABLE 2-25**  
**MINIMUM INBOUND OFF-STREET RESERVOIR REQUIREMENTS<sup>1</sup>**

Land Use	Reservoir Requirements <sup>2</sup>
Drive-In Bank (ATM or full-service teller)	5 spaces per lane or 8 spaces for first window and 4 for each additional window
Pharmacy Window	5 spaces per lane
Mechanical Car Wash	10 spaces per bay or lane
Fast Food Restaurant	10 spaces per bay or lane
Auto Maintenance/Services	3 spaces per bay or lane
<b>Parking Facility</b>	
• Free-Flow Entry	1 space per entry driveway
• Ticket Dispenser Entry	2 spaces per entry driveway
• Manual Ticket	8 spaces per entry driveway
• Attendant Parking	10% of that portion of parking capacity served by attendant-controlled driveway

<sup>1</sup> These reservoir requirements may be changed, when deemed necessary, by the Department of Planning and Zoning. No vehicle queuing will be allowed on adjacent roadway.

<sup>2</sup> Each space shall be 22 feet long – Source: Transportation Research Board *Parking Principles*, 1971 Special Report 125. The reservoir lane shall be a minimum of 12 feet wide.

The parking lot design shall discourage random movements and, through the use of traffic engineering aids such as signs and islands, provide positive guidance to the motorist and shall minimize conflicts. Parking lot islands landscaped with deciduous trees are desired to provide shade in warm weather and reduce the temperature of the street's stormwater runoff. Design guidance for parking lot islands is available in the Howard County Landscape Manual. It is also recommended to clearly delineate walking and bicycling access and ensure that any ornamental landscaping does not limit incidental surveillance and become a detriment to safety. Lighting of the medians is also important to enhance the safety of all users. Parking lot lighting guidance is provided in the Howard County Zoning Regulations. Efforts shall be made to minimize vehicle and pedestrian conflicts.

Reserved parking for persons with disabilities shall be provided in all off-street parking areas in accordance with current Maryland Accessibility Code Guidelines (MACG) for Building and Facilities requirements. One in every four of the reserved spaces, but not less than one, shall be designated "Van Accessible". The reserved parking spaces and access aisles shall be level with surface slopes not exceeding 2% in all directions. Refer to the Americans with Disabilities Act Accessibility Guidelines (ADAAG) for further details. The number of off-street parking spaces reserved for persons with disabilities shall be provided in accordance with the MACG and ADAAG.

Curb ramps should be located so as to provide easy and direct access between the reserved parking spaces for persons with disabilities and the building entrance.

Off-street parking and storage lots shall have paved (asphalt or concrete) surface in accordance with the standard details in Volume IV. Other materials may be considered if the storage lot is expected to accommodate track vehicles.

**D. Bicycle Parking**

Bicycle parking shall be designed in accordance with the latest edition of the “Bicycle Parking Guidelines” published by the Association of Pedestrian and Bicycle Professionals (Ref. 32). Bicycle parking shall be located in a location that is convenient to destinations but retains sufficient clearance for circulation by people walking and bicycling.

**E. Perpendicular Parking**

In single family, semi-detached or single family attached, or apartment developments, perpendicular parking along public streets will only be allowed on streets where the ADT is 1,000 or less. Plans should indicate that the entirety of the parking space, in or out of the public right of way, should be privately maintained.

## 2.7 Street Lighting

Street lighting, where properly designed and installed, can greatly enhance a community's environment. Though lighting is desirable at virtually all locations, economics and concern for energy requirements dictate that it be restricted to those areas that will experience the greatest benefit.

### A. Design and Installation

Design and installation will be implemented in one of several ways:

1. Major Capital Project: As part of the design of a new street or upgrade of an existing street, new street lights will be designed into this type of project. The type and spacing of the street lights will be determined by the classification of the street, number of lanes, and anticipated ways/functions of the roadway.
2. Existing County Streets: Along existing County streets, upgraded lighting will be designed as needs are identified and funds are available.
3. Existing Local/Community Streets: Along residential streets, new or upgraded lighting will be designed based on requests from the local community, field evaluations and available funds.
4. New Developments: As part of the subdivision review process, street lights will be designed into new development/street projects. The process for review and implementation of street lights in development projects includes the following:
  - a. Standards and Guidelines for Street Lighting in New Subdivisions

These Standards and Guidelines are designed to implement the "Subdivision and Land Development Regulations" that state:

"Unless the Department of Planning and Zoning, after consultation with the Director of Public Works, determines that adequate street lighting already exists, the developer of subdivisions and site developments shall provide street lighting in accordance with the Design Manual...". (ART III, Section 16.135 Street Lighting)

The developer shall be totally responsible for the material and labor costs in connection with installing street light poles and luminaires, including relocations and/or changes made to new or existing lighting systems. The developer shall also be totally responsible for all energy and maintenance costs incurred for a period of two (2) years.

#### b. Procedure

- 1) After the Road Construction Plan has been approved and signed, the Department of Department of Public Works-Traffic Division (DPW) shall prepare a cost estimate based on the lighting system designed. The lighting system shall be in compliance with the guidelines set forth herein and shall be selected in accordance with BGE's approved Hardware List.

The cost estimate shall include the following:

- (a) Hardware and Installation costs;
  - (b) Energy, Inspection and Maintenance charges for two (2) years (based on the size and type of the lamp).
- 2) The street lighting layout along with a description of the hardware shall be forwarded to BGE' for processing by the Traffic Division, Bureau of Highways.

\*Note BGE installs and maintains all County public street lights.

- 3) The Department of Public Works, Real Estate Services Division upon receipt of a cost estimate from the Department of Public Works, Traffic Division, shall begin the Development Agreement process by notifying the developer of all costs associated with the proposed street lighting system.
- 4) Upon receipt of a certified check in the amount of the estimated costs prepared by the DPW-Traffic Division, the Department of Public Works shall authorize the utility company to install the street lighting system in accordance with the street lighting layout.
- 5) When the developer formally petitions the Department of Public Works to accept a street(s) and associated improvements into the public system, all damage to any street light pole(s) and fixture(s) as a result of construction or vandalism prior to such acceptance, must be satisfactorily corrected. Personnel of the Department of Public Works shall inspect for damage and correction of same.

## **B. General Street Light Guidelines**

1. Consider safety for all users of the street when selecting street lighting types and locations.
2. When requested, the determination of need for lighting of capital improvement projects shall be made by the Traffic Division, Bureau of Highways. Factors to be considered include street width, roadside obstacles, speed, walking and bicycling traffic, and crash history.
3. All intersections and midblock crossings located within the Water & Sewer Districts shall have a minimum of one street light. The determination of need for additional lighting, as well as the design of a lighting system, shall be subject to review and approval by the Department of Public Works/Traffic Engineering Division.
4. Street Light Location and Spacing

Along minor collectors and residential streets, street lights shall be installed to provide a lateral clearance of 3 feet from the back of curbs. Along major collector and arterial streets the lateral set-back shall be a minimum of 4' from the back of the curb for closed section roadways or 6' from the edge of pavement on open section roadways.

The placement of street lights along County streets shall be determined by the Traffic Division/Bureau of Highways/DPW based upon the street type, horizontal and vertical alignment, vehicle volume, intersection design, crash history, walking and bicycling traffic, and area zoning (when applicable).

5. Acceptable Street Light Poles and Fixtures

**TABLE 2-26  
ACCEPTABLE STREET LIGHT POLES AND FIXTURES\***

Roadway Classification	Minimum Pole Height (feet)	Pole Type	Fixture	Lamp Type & Size
Residential	14'	Black Fiberglass	<u>Post Top</u> : Premier or Acorn	LED - 100 or LED - 150
Minor Collector or Major Collector	14'	Black Fiberglass	<u>Post Top</u> : Premier or Acorn	LED - 100 or LED - 150
	30'	Bronze Fiberglass	Pendant	LED - 150 or LED - 200
	23'	Black Fiberglass	Teardrop	LED - 150
Arterials	30'	Bronze Fiberglass	Pendant	LED - 250 or LED - 400
	23'	Black Fiberglass	Teardrop	LED - 250

\* The actual type, spacing and size of lamp will be determined by the Traffic Division/Bureau of Highways/DPW.

**C. Parking Lot/Area Lighting**

The minimum illumination levels for all parking areas (public or private) shall comply with the values stipulated in Table 2-27. Howard County Zoning Regulations provide additional requirements for lighting on private property.

**TABLE 2-27  
PARKING AREAS (PUBLIC OR PRIVATE)  
MINIMUM MAINTAINED HORIZONTAL ILLUMINATION**

Commercial			Residential		
Zoning	Minimum Illumination (footcandles)	Uniformity Ratio	Zoning	Minimum Illumination (footcandles)	Uniformity Ratio
H-O	0.9	6:1	R	Not Applicable	Not Applicable
H-C	0.9	6:1	R-ED	Not Applicable	Not Applicable
POR	1.0	6:1	R-20	0.4	6:1
CC	1.2	4:1	R-12	0.4	6:1
B-1	1.2	4:1	R-SC	0.9	6:1
B-2	1.2	4:1	R-SA-8	0.6	4:1
SC	0.9	4:1	R-A-15	0.6	4:1
M-1	0.9	6:1	R-MH	0.9	6:1
M-2	0.9	6:1	R-HR	0.4	6:1
ID	0.6	6:1	R-VH	0.4	6:1
PEC	0.9	6:1			
NT	0.9	4:1			
PGCC	0.6	4:1			

## 2.8 Detailed Design Elements

### A. Alleys

Alleys are streets that provide vehicular access to properties with frontages on a public street and generally follow the pattern of adjoining streets. Alleys are not considered private streets. Alleys in all residential areas should be for rear access to residential units and shall have a minimum width of 20 feet. Alleys greater than 200 feet in length that have a single access point shall terminate with a cul-de-sac or a tee-turnaround that provides adequate spacing for emergency vehicles to exit the alley without having to back completely out of the alley and/or back into private residential driveways when exiting the area. Alleys shall have a maximum grade of 10 percent with vertical clearance of 13.5 feet and have a minimum stopping sight distance of 120 feet. The elevation of the outside edges of the alley shall be two inches lower than the finished grade of the adjoining property. The angle of intersection between an alley entrance and a street, measured between the alley centerline and the street edge of pavement, shall be 90 degrees unless otherwise approved.

### B. Private Streets

Private streets are low volume streets that serve a number of properties, generally in a rural area. Where allowed by subdivision regulations, private streets may be utilized. They shall be constructed to public street standards.

### C. Curb and Gutter

Curb and gutter shall be in accordance with the Standard Details as shown in Volume IV.

The following are the permitted uses for the various types of curb:

- Standard Combination Curb and Gutter: Any street; required at all street intersections.
- Modified Combination Curb and Gutter: Access Place, Access Street and minor collector streets in residential areas; Neighborhood Yield Streets and Neighborhood Connectors; and on raised shoulders
- Standard MDOT SHA Type C Combination Curb and Gutter: for truck aprons
- Bituminous Curb: Shall only be used for temporary installation.
- Flush Curb: Shall be used on the inside of all open section curves with a radius of 1,000 feet or less unless an alternative edge treatment is approved by the Department of Public Works.
- Monolithic Curb: Private parking area only.

### D. Side Slopes

Side slopes for excavations and embankments should be as flat as feasible considering earthwork and right-of-way requirements. The normal maximum slope shall be 2:1. Where poor soil conditions exist, soil tests and a slope stability analysis shall be conducted and certified by a qualified engineer to determine an acceptable slope.

Side slopes adjacent to shared use paths and sidewalks are discussed in Section 2.2.C.2.

Reference shall be made to “Standards and Specifications for Soil Erosion and Sediment Control in Developing Areas” for regulations concerning the treatment of slopes to provide erosion control, and for temporary and permanent stabilization requirements.

The intersection of a cut slope and the existing ground shall be rounded as shown in the Standard Details, Volume IV.

All slopes shall be covered with 4” topsoil and seeded and mulched. Other stabilization materials beside grass may be used subject to Department of Public Works.



## E. Traffic Barrier

Traffic barrier is required at certain roadside obstacles and along some embankments to reduce the severity of run-off-the-road type crashes. It should only be installed where the severity of a crash with the traffic barrier will be less than that which would occur were the traffic barrier not present.

Combinations of embankment slope and height warranting traffic barrier are shown in Appendix F. Wherever feasible, the embankment should be adjusted to eliminate the need for traffic barrier. Where traffic barrier is warranted, it shall be placed as shown in MDOT SHA Standard Details.

Factors to be considered when determining the need for traffic barrier at fixed roadside objects include design speed, roadway functional classification, type of obstacle and distance from pavement edge to the obstacle. Traffic barrier shall conform to the standard details, except that weathered steel traffic barrier may be used on scenic roads and along cul-de-sac roads, access place, access street and minor collectors in residential areas.

Traffic barrier W-beam shall normally be extended from the fill into the cut as shown in MDOT SHA Standard Details. Where a long low fill not requiring traffic barrier is adjacent to a fill that does warrant traffic barrier, the traffic barrier may be started or ended on the low fill in accordance with MDOT SHA Standard Details.

Placement of traffic barrier W-beam adjacent to a closed section roadway shall be evaluated on a case-by-case basis when there is a roadside obstacle, a hazardous embankment, or as indicated in the typical sections. If any of these conditions warrant a traffic barrier, it shall be placed in accordance with MDOT SHA Standard Details.

If traffic barrier W-beam must be placed between the roadway and either a sidewalk, bikeway, or shared use path, the back of post shall be out of the clear zone as defined for a shared use path to avoid collisions with the posts. The back of posts can be made more pedestrian and bicycle friendly through provision of a double-face (median) traffic barrier W-beam or introduction of post caps to cover the sharp edges of metal posts. Consult with the Department of Public Works for acceptable treatments.

Rail rider reflectors shall be installed on all traffic barrier W-beam at a spacing of two times the design speed.

Concrete Barrier may be used as an alternate to traffic barrier W-beam subject to the review and approval of the Department of Public Works.

## F. Underdrain

Longitudinal underdrain shall be used to drain the pavement section. Longitudinal underdrain shall be located at the outside edge of shoulder in open section and behind curb in closed section.

Underdrain is generally placed at low points along the roadway profile and along the low side of the superelevation.

Underdrain shall outlet into side ditches or drainage inlet structures

## G. Ditches

Roadside ditches shall conform to the Typical Sections of Volume IV and Volume I, Storm Drainage Design Manual.

## H. Staged Construction

Consideration should be given to staged construction when it is determined by traffic analysis that a given street will initially require a much smaller section than the ultimate. A typical example of this condition is a four-lane divided boulevard. Four lanes may be required in the design year but the construction of only one of the two-lane roadways might be sufficient for a number of years beyond initial construction.

Factors to be considered include level of service provided by the initial construction, the ability to provide pedestrian and bicycle accommodation with the initial construction, time until widening is required, cost of initial and ultimate construction, ease with which the ultimate section can be added to the initial section and maintenance of traffic problems which may occur during the ultimate construction.

Care must be exercised that the change from the initial to the ultimate section will not result in an undue amount of reconstruction. An example is a road over passing another road being built under staged construction. In such a case, the ultimate section, not just the initial, shall be spanned.

As a guideline, staged construction should be considered only when the time between initial and ultimate construction would be greater than five years.

## I. Bus Stops

In many situations, bus stops will be located such that buses will stop within a travel lane. In some instances, it may be desirable to locate a bus stop within a bus turnout lane, such as at a bus layover location. In these cases, a bus turnout lane shall be provided where directed by the Department of Public Works or Department of Planning and Zoning. The turnout lane shall be 12 feet wide by 50 feet long with transition tapers to existing pavement edge on each end. The length of transitions taper shall be based on the street design speed, grades and traffic conditions for vehicles to safely diverge and merge into thru traffic. Turnout transitions shall be at a minimum 75 feet in length. Turnouts shall not interrupt the bicycle accommodation provided in the corridor.

A minimum 5-foot sidewalk shall be adjacent to the bus turn out lane. If required by Department of Public Works, a bus shelter pad shall be provided. For continuity, the sidewalk shall connect to adjacent sidewalks for complete access to the bus stop, including from all corners of an adjacent intersection where necessary to provide pedestrian access, in accordance with Section 2.4.E. To provide full access to bus stops, crosswalks shall be provided and comply with ADA accessibility requirements. Requirements for crosswalks are presented in Section 2.4.E.1

As noted in Section 2.4.G, Maryland Department of Transportation Maryland Transit Administration (MDOT MTA) "Bus Stop Design Guide" provides more guidance for the design of bus stops (Ref. 29). Where on-road bike lanes are present, a boarding island stop (also known as a floating bus stop) should be considered. The floating bus stop allows for bicycle traffic to travel behind the bus stop, eliminating the conflicts found between buses and bicycles at in-lane stops. Guidance for boarding island stops is provided in the "Bus Stop Design Guide." For provision of boarding island bus stops on Boulevards, Town Center Connectors, and Town Center Streets, transit users will cross the separated bike lane for access between the sidewalk and the bus stop. To facilitate this transition, the guidance in Section 2.6 of the Bus Stop Design Guide should be referenced, with a potential configuration of design elements as shown in Figure 2-41.

Figure 2-41. Sample Bus Boarding Area configurations for Boulevards, Town Center Connectors, and Town Center Streets, with and without parking lanes.

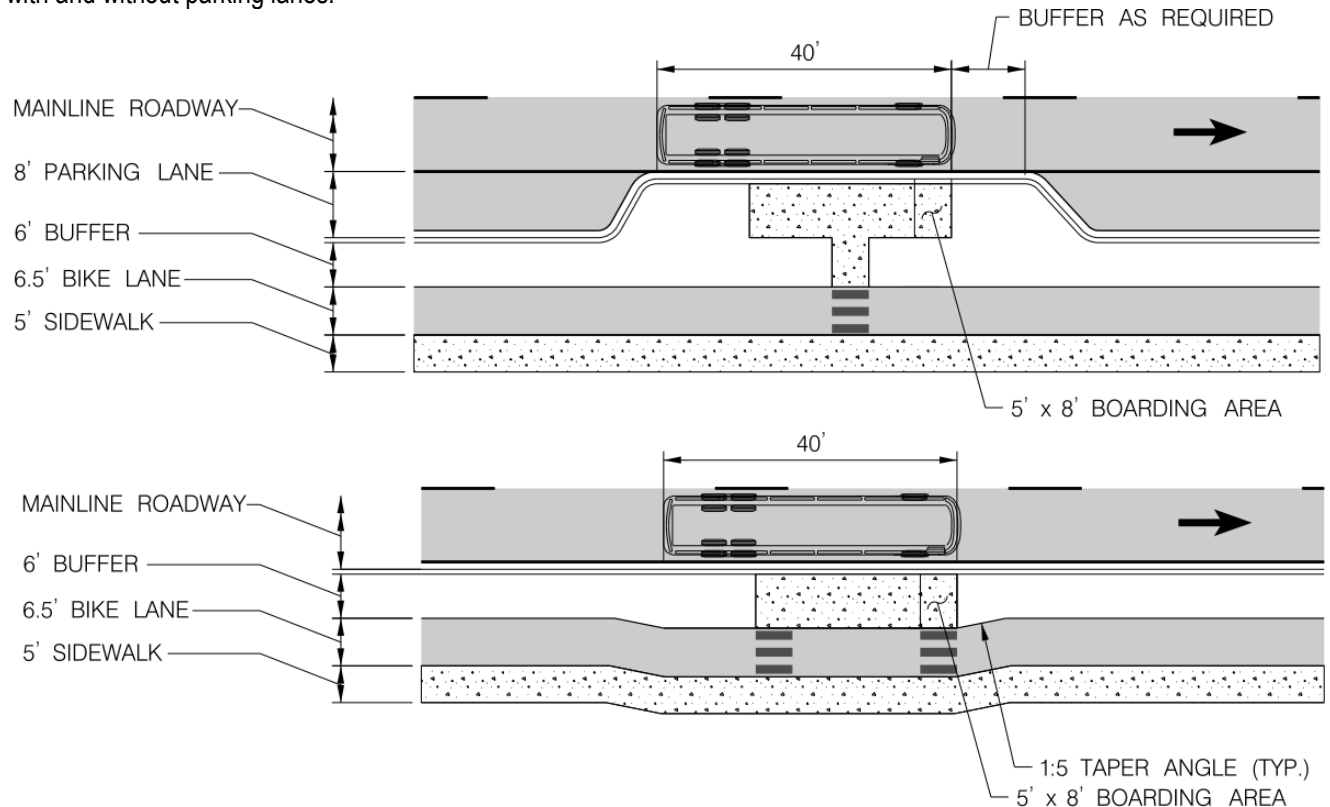

## J. Scenic Roads

Carefully designed localized improvements to improve safety for motorists and people bicycling are allowable provided that they retain the scenic quality of the road. Bicycle accommodation consistent with the Bicycle Master Plan Shared Roadway with Safety Treatments is permissible on scenic roads.

The standards for maintenance of scenic roads shall be as the follows:

1. Do not alter the existing width of the pavement or shoulders or the roadway alignment during road, utility or drainage maintenance. Pavement restriping, removal of vegetation and signage installation is permitted to improve safety.
2. Maintain roadway embankments to be a natural characteristic of the road. Mitigate erosion and similar problems by plantings.
3. Limit tree trimming and removal to work necessary to improve sight distance, safety and for prudent forest management. Minimize disturbance to mature trees.
4. Control vegetation as necessary by mowing or selective cutting. Allow natural vegetation to become established as close to the shoulders edge as possible, while allowing for adequate sight distance.
5. If street lights are installed, they should be installed to the lowest height feasible for the location, fixtures should be directed downwards onto the road, and lights should be of the material and style compatible with the neighborhood.
6. Materials to repair bridge and walls should match existing materials.

## K. Mailbox Placement

Mailbox placement should be avoided along high-speed, high-volume streets. Placement should generally be on the right side of the street beyond an intersection or private driveway. Mailboxes shall only be placed on the right side in the direction of travel except on one-way streets, where the placement may be on the left side.

On high-speed, high volume streets, mailboxes should be placed 10 to 12 feet off the edge of travel way with a paved shoulder. The face of the mailbox should be placed 8 to 12 inches outside of the edge of travel lane or shoulder. Mailboxes may be located behind traffic barrier where appropriate. In areas of curb and gutter, the face of the mailbox should be set back 6 to 8 inches from the face of curb.

Where sidewalks or shared use paths are present, mailboxes shall not interfere with passage of people walking and bicycling. Mailboxes are subject to the provisions of Section 2.2.C.2 regarding vertical objects adjacent to a path. Sidewalks and shared use paths should be designed to provide accommodation for mailboxes; sidewalks which must be placed at the back of curb due to constraints shall have widening behind the normal line of sidewalk as needed to provide bypass areas at the mailbox meeting ADA requirements per Section 2.2.B.

## L. Solid Waste Containerization

### 1. General

To adequately accommodate the storage, collection, and removal of refuse at commercial, industrial or institutional development, multi-family residential complexes, single family detached residential on a common driveway and mobile home parks, the following criteria must be met.

### 2. Definition

- a. Refuse Storage Area is defined as that space on the premises where refuse is deposited by occupants and stored until it is transferred to a collection or processing vehicle and removed from the premises.
- b. Maneuver Space is defined as that portion of the premises upon which the collection vehicle must travel on its trip from the street to the refuse storage area(s) and exit.

### 3. Bulk Container Service Pad

Where required, the container must be placed on a level area easily accessible to a front-end loader to allow for uninterrupted service access at any time. Refuse storage areas shall be located to reduce visual and olfactory nuisance to adjoining properties and the public right-of-way. The location and alignment shall be approved by the Department of Public Works or Department of Planning and Zoning.

Each bulk container shall be placed on a concrete pad with concrete apron, see Standard Details, Volume IV.

### 4. Maneuver Space Requirements

Minimum overhead clearance: 24 feet unobstructed. Minimum width: 15 feet, unobstructed straight approach for tender truck.

Minimum length: 42 feet, unobstructed straight approach for tender truck.

The maneuver space shall accommodate a truck with a 300-inch wheel base and 38 foot turning radius with an access drive grade not to exceed 8 percent. The area shall be designed to avoid backing the truck into a traffic lane of a public thoroughfare.

Where multiple containers are grouped, a minimum space of two (2) feet must be maintained between adjacent containers. Visual screens are not required; however, if used, at least three (3) feet of clearance space on the sides and rear is required.

Where refuse containers are required, such as in multi-family developments and industrial areas, sufficient area for them and the trucks serving them shall be included in the parking area. A plan showing truck turning paths for loading, deliveries, and refuse collection should be included in the site plan set.

#### 5. Design Unit Size and Location

Each individual dwelling unit in a multi-family residential area or mobile home park shall be provided either with an individual or centralized refuse storage area within approximately 200 feet of the dwelling unit or occupancy it serves. For a single family detached residential use in a common driveway, a collection area that is screened from adjacent properties by landscaping shall be provided along the public street.

Residential complex units consisting of more than ten (10) individual residential units shall obtain and use bulk containers for refuse within approximately 200 feet of the dwelling unit or occupancy it serves.

Only six (6) cubic yard and eight (8) cubic yard gravity type, stationary containers will be approved by the County. (One (1) six cubic yard container will serve approximately fifteen (15) dwelling units and one (1) eight (8) cubic yard container will serve approximately 20 dwelling units. However, it must be taken into consideration whether the units are 1, 2, or 3 bedrooms and whether trash compactors are used.)

Each container shall be of a design that can be serviced by Howard County Contractor's Container Tender Truck. Bulk containers shall have sliding metal doors in lieu of swinging doors with spring latches.

## 2.9 References

- (1) "A Policy on Geometric Design of Highways and Streets," American Association of State Highway and Transportation Officials (AASHTO), 7th Edition (2018) or latest edition
- (2) "Traffic Engineering Handbook," Institute of Transportation Engineers, 7th Edition (2016) or latest edition
- (3) "Bicycle Policy Design Guidelines," Maryland Department of Transportation State Highway Administration (MDOT SHA), (2015) or latest edition
- (4) "Accessibility Policy & Design Guidelines for Pedestrian Facilities Along State Highways," Maryland Department of Transportation State Highway Administration (MDOT SHA), (2010) or latest edition
- (5) "Manual on Uniform Traffic Control Devices (MUTCD)," Federal Highway Administration (FHWA), 2009 Edition with Revision Numbers 1 and 2 (2012) or latest edition
- (6) "Book of Standards Temporary Traffic Control Devices Typical Applications," Maryland State Highway Administration (MDSHA), latest edition
- (7) "Guide for the Development of Bicycle Facilities," American Association of State Highway and Transportation Officials (AASHTO), 4th Edition (2012) or latest edition
- (8) "Supplemental Notice on Shared Use Paths, (Proposed) Public Rights of Way Accessibility Guidelines (PROWAG)," U.S. Access Board, (2011) or latest edition
- (9) "Shared-Use Path Level of Service Calculator," Federal Highway Administration (FHWA), (2006) or latest version
- (10) "Maryland Manual on Uniform Traffic Control Devices (MdMUTCD)," Maryland Department of Transportation State Highway Administration (MDOT SHA), (2011) or latest version
- (11) "Bikeway Selection Guide," Federal Highway Administration (FHWA), (2019) or latest edition
- (12) "Urban Bikeway Design Guide," National Association of City Transportation Officials (NACTO), 2nd Edition (2014) or latest edition
- (13) "Separated Bike Lane Planning and Design Guide," Federal Highway Administration (FHWA), (2015) or latest edition
- (14) "NCHRP Report 672, Roundabouts: An Informational Guide," National Cooperative Highway Research Program (NCHRP), 2nd Edition (2010) or latest edition
- (15) "Achieving Multimodal Networks," Federal Highway Administration (FHWA), (2017) or latest edition
- (16) "Road Diet Informational Guide," Federal Highway Administration (FHWA), (YEAR) or latest edition
- (17) "Traffic Calming e-Primer," Federal Highway Administration (FHWA), (YEAR) or latest edition
- (18) "Delaware Traffic Calming Design Manual," Delaware Department of Transportation (DelDOT), (2012) or latest edition
- (19) "Howard County Landscape Manual," Howard County, (1998 edition with 2010 update) or latest edition
- (20) "Roundabout Design Guidelines," Maryland State Highway Administration (MDOT SHA), (2012) or latest edition
- (21) "Intersection Control Evaluation (ICE)," Federal Highway Administration (FHWA), (2021) or latest edition



- (22) "Guide for Improving Pedestrian Safety at Uncontrolled Crossing Locations," Federal Highway Administration (FHWA), (2018) or latest edition
- (23) "Separated Bike Lane Planning and Design Guide," Massachusetts Department of Transportation, (YEAR) or latest edition
- (24) "Don't Give Up at the Intersection National Association of City Transportation Officials (NACTO), (2019) or latest edition
- (25) "Interim Approval for Optional Use of an Intersection Bicycle Box (IA-18)," Federal Highway Administration (FHWA), (2016)
- (26) "Interim Approval for Optional Use of Two-Stage Bicycle Turn Boxes (IA-20)," Federal Highway Administration (FHWA), (2017)
- (27) "Small Town and Rural Multimodal Networks," FHWA, (2016) or latest edition
- (28) "Interim Approval for Optional Use of Green Colored Pavement for Bike Lanes (IA-14)," Federal Highway Administration (FHWA), (2011)
- (29) "Interim Approval for Optional use of a Bicycle Signal Face (IA-16)," Federal Highway Administration (FHWA), (2013)
- (30) "Bus Stop Design Guide," Maryland Department of Transportation Maryland Transit Administration (MDOT MTA), (2019) or latest edition
- (31) "NCHRP Report 659, Guide for the Geometric Design of Driveways," National Cooperative Highway Research Program (NCHRP), (2010) or latest edition
- (32) "Bicycle Parking Guidelines," Association of Pedestrian and Bicycle Professionals (APBP), (2015) or latest edition

## Appendices

- A. Public Roadway Design Criteria
- B. Horizontal Circular Curve
- C. Vertical Curve
- D. Types of Vertical Curves
- E. Method of Attaining Superelevation
- F. Traffic Barrier Required for Embankment Geometry
- G. Parking Stall Layout Elements
- H. Intersection Sight Distance
- I. Sidewalk Expansion Policy

# PUBLIC ROADWAY DESIGN CRITERIA

## 1. RESIDENTIAL STREETS DESIGN CRITERIA SUMMARY – OPEN CROSS SECTION

CLASSIFICATION	MAXIMUM VOLUME AVG. DAILY TRAFFIC (ADT)	DESIGN SPEED (MPH)	PAVEMENT WIDTH (FT.)	* MAX. DIST. BETWEEN SPEED CENTRAL DEVICES (FT.)	MINIMUM CURVE RADIUS (FT.)	SIDEWALK	CURB	RIGHT OF WAY WIDTH (FT.)
USE-IN-COMMON	60	15	15	NA	45	NA	NA	24
ACCESS PLACE	200	25	22	NA	210	NA	NA	50
ACCESS STREET	500	30	24	510	350	NA	NA	50
MINOR COLLECTOR	1,000	35	28	600	550	NA	NA	50

## 2. RESIDENTIAL STREETS DESIGN CRITERIA SUMMARY – CLOSED CROSS SECTION

CLASSIFICATION	MAXIMUM VOLUME AVG. DAILY TRAFFIC (ADT)	DESIGN SPEED (MPH)	PAVEMENT WIDTH (FT.)	* MAX. DIST. BETWEEN SPEED CENTRAL DEVICES (FT.)	MINIMUM CURVE RADIUS (FT.)	SIDEWALK	CURB	RIGHT OF WAY WIDTH (FT.)
ACCESS PLACE	200	25	24	NA	210	SUB. REGS. SEC. 16.134	MODIFIED	50
ACCESS STREET	1,000	30	24	510	350	SUB. REGS. SEC. 16.134	MODIFIED	50
MINOR COLLECTOR	2,000	35	28	600	550	SUB. REGS. SEC. 16.134	STANDARD	50

## 3. NON-RESIDENTIAL STREETS DESIGN CRITERIA SUMMARY

CLASSIFICATION	MAXIMUM VOLUME AVG. DAILY TRAFFIC (ADT)	DESIGN SPEED (MPH)	PAVEMENT WIDTH (FT.)	* MAX. DIST. BETWEEN SPEED CENTRAL DEVICES (FT.)	MINIMUM CURVE RADIUS (FT.)	SIDEWALK	CURB	RIGHT OF WAY WIDTH (FT.)
LOCAL ROADS & CUL-DE-SACS	1,000	30	CLOSED 40	NA	350	SUB. REGS. SEC. 16.134	STANDARD	60
MINOR COLLECTOR	2,000	35	CLOSED 40	NA	550	SUB. REGS. SEC. 16.134	STANDARD	60
MAJOR COLLECTOR	-	40	CLOSED 40	NA	SEE TABLE 2.03	SUB. REGS. SEC. 16.134	STANDARD	60
ARTERIAL								
MINOR	-	40						100
INTERMEDIATE	-	50	VARIABLE	NA	SEE TABLE 2.03	AS REQUIRED	STANDARD	100
DIVIDED	-	50						150

\* FOR CAPITAL IMPROVEMENT PROJECTS ONLY

### NOTES:

1. GUIDANCE IN APPENDIX A IS TO BE USED FOR RETROFIT PROJECTS WITH THE APPROVAL OF THE DEPARTMENT OF PUBLIC WORKS. SEE TABLE 1-13 IN CHAPTER 1 FOR NEW ROADWAY DESIGN
2. RESIDENTIAL STREETS DESIGN CRITERIA SUMMARY – OPEN CROSS SECTION
  - a. FLUSH CURB ON INSIDE OF ALL CURVES WITH RADIUS OF 1000' OR LESS.
  - b. STANDARD CURB REQUIRED AT ALL STREET INTERSECTIONS.
  - c. ROADS LEADING TO CLUSTER DEVELOPMENT AREAS MAY BE DESIGNED AS A MINOR COLLECTOR WITH A TRAFFIC CALMING FEATURE AT THE BEGINNING OF AN ACCESS STREET.
3. ASSUME RESIDENTIAL DWELLING = 10 ADT. FOR A MORE ACCURATE DEFINITION SEE ITE TRIP GENERATION MANUAL, LATEST EDITION.
4. PAVEMENT WIDTH SHALL BE INCREASED AT INTERSECTIONS AS NEEDED PER TURNING TEMPLATE OF DESIGN VEHICLE.
5. MAXIMUM DISTANCE BETWEEN SPEED CONTROL DEVICES
  - a. SPEED CONTROL DEVICES ARE NOT REQUIRED ON ROADWAYS LESS THEN 1,200' LONG.
  - b. SPEED CONTROL DEVICES ARE NOT REQUIRED ON PORTIONS OF ROADWAYS WITH LESS THEN 1,200' BETWEEN INTERSECTION CONTROL (STOP SIGNS, YIELD SIGNS, ROUNDABOUTS, TRAFFIC SIGNALS).
  - c. ROADWAYS AND PORTIONS OF ROADWAYS NOT MEETING ITEM 4a. OR 4b. SHALL ADHERE TO THE MAXIMUM DISTANCE BETWEEN SPEED CONTROL DEVICES REQUIREMENTS.
6. ANY ACCESS PLACE AND ACCESS STREET IN TOWNHOUSE, DEVELOPMENT WILL REQUIRE 26' OF PAVEMENT WIDTH.

### APPENDIX A

DRAWN BY:	WRA
CHECKED BY:	WRA
SCALE:	

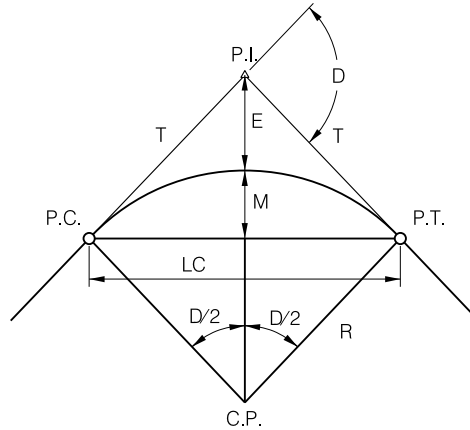

DEFINITIONS AND SYMBOLS

- P.I. – POINT OF INTERSECTION  
THE POINT AT WHICH TWO TANGENTS TO THE CURVE INTERSECT.
- P.C. – POINT OF CURVATURE  
THE POINT AT WHICH THE TANGENT ENDS AND THE CURVE BEGINS.
- P.T. – POINT OF TANGENCY  
THE POINT AT WHICH THE CURVE ENDS AND THE TANGENT BEGINS.
- D – DELTA OR INTERSECTION ANGLE ( $D = D_c * L / 100$ )  
THE DEFLECTION ANGLE BETWEEN THE TANGENTS AT THE P.I. THIS IS EQUAL TO THE CENTRAL ANGLE SUBTENDED BY THE CURVE.
- $D_c$  – DEGREE OF CURVE ( $D_c = 100 * D / L$ )  
THE CENTRAL ANGLE SUBTENDED BY AN ARC OF 100 FEET. THIS IS THE ARC DEFINITION OF A CURVE AND SHALL BE USED FOR ALL ROAD AND STREET PROJECTS.
- R – RADIUS ( $R = 5729.578 / D_c$ )  
THE DISTANCE BETWEEN THE CENTERPOINT AND ANY POINT ON THE CURVE.
- T – TANGENT DISTANCE ( $T = R * \tan(D / 2)$ )  
THE DISTANCE BETWEEN THE P.C. AND THE P.I. OR BETWEEN THE P.I. AND THE P.C.
- L – LENGTH OF CURVE ( $L = 100 * D / D_c$ )  
THE ARC DISTANCE BETWEEN THE P.C. AND THE P.T.
- LC – LONG CHORD ( $LC = 2 * R * \sin(D / 2)$ )  
THE STRAIGHT LINE DISTANCE BETWEEN THE P.C. AND THE P.T.
- E – EXTERNAL DISTANCE ( $E = T * \tan(D / 4)$ )  
THE DISTANCE BETWEEN THE P.I. AND THE MIDDLE OF THE CURVE.
- M – MIDDLE ORDINATE ( $M = R (1 - \cos(D / 2))$ )  
THE DISTANCE BETWEEN THE MIDDLE OF THE CURVE AND THE MIDDLE OF THE LONG CHORD.
- C.P. – CENTER POINT OF THE CURVE

APPENDIX B

HOWARD COUNTY, MARYLAND  
DEPARTMENT OF PUBLIC WORKS

HORIZONTAL CIRCULAR CURVE

DRAWN BY:	WRA
CHECKED BY:	WRA
SCALE:	NO SCALE
DEC. 2017	

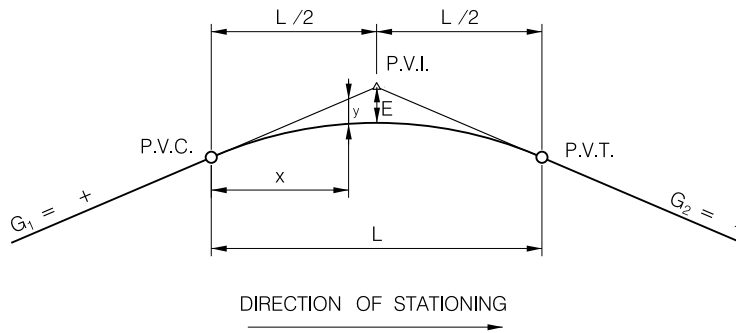

DEFINITIONS

- P.V.I. – POINT OF VERTICAL INTERSECTION
- P.V.C. – POINT OF VERTICAL CURVATURE
- P.V.T. – POINT OF VERTICAL TANGENCY
- $G_1$  &  $G_2$  – GRADE OF TANGENTS, IN PERCENT, WITH UPGRADES IN DIRECTION OF STATIONING BEING POSITIVE AND DOWNGRADES BEING NEGATIVE
- L – TOTAL LENGTH OF VERTICAL CURVE, IN STATIONS
- E – VERTICAL OFFSET FROM P.V.I. TO THE MIDDLE OF THE CURVE, IN FEET
- y – VERTICAL OFFSET IN FEET FROM A POINT ON THE TANGENT TO AN INTERMEDIATE POINT ON THE CURVE
- x – HORIZONTAL DISTANCE FROM THE P.V.C. TO ANY POINT ON THE CURVE, IN STATIONS

APPENDIX C

HOWARD COUNTY, MARYLAND  
DEPARTMENT OF PUBLIC WORKS

VERTICAL CURVE

DRAWN BY:	WRA
CHECKED BY:	WRA
SCALE:	NO SCALE
DEC. 2017	

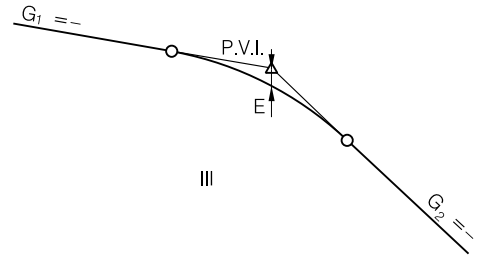
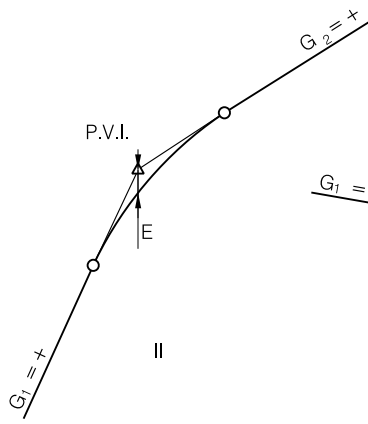
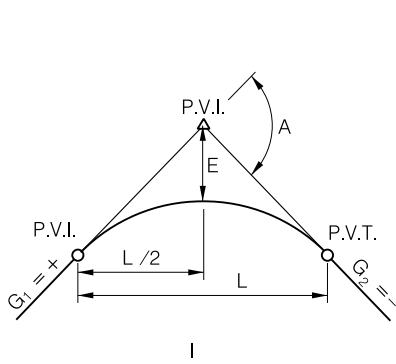

CREST VERTICAL CURVES

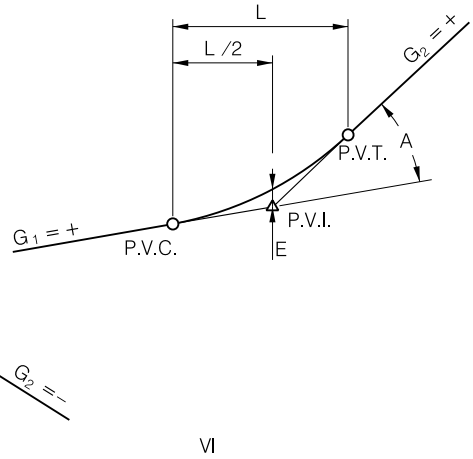
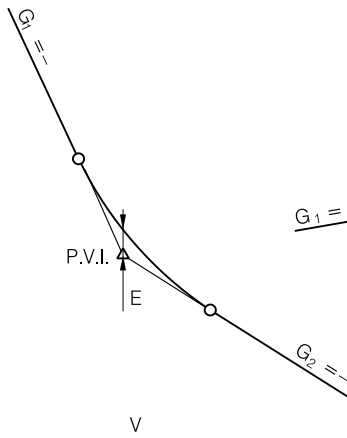
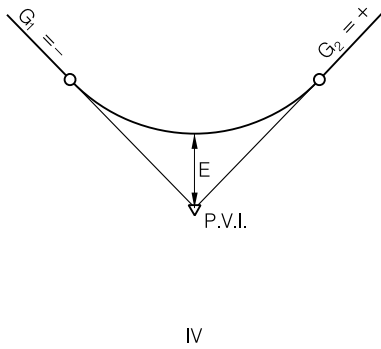

SAG VERTICAL CURVES

$G_1$  &  $G_2$  – GRADE OF TANGENTS, IN PERCENT  
 $A$  – ALGEBRAIC DIFFERENCE IN GRADE  
 $L$  – LENGTH OF VERTICAL CURVE

APPENDIX D

HOWARD COUNTY, MARYLAND  
 DEPARTMENT OF PUBLIC WORKS

TYPES OF  
 VERTICAL CURVES

DRAWN BY: WRA  
 CHECKED BY: WRA  
 SCALE: NO SCALE  
 DEC. 2017

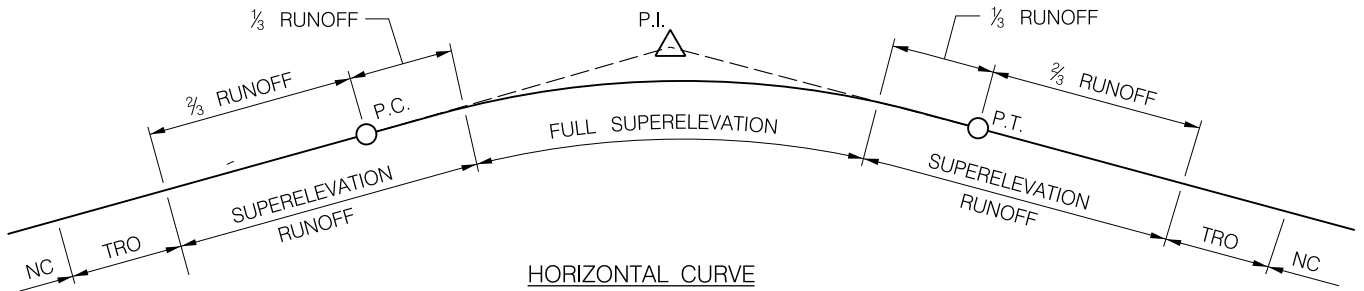

HORIZONTAL CURVE

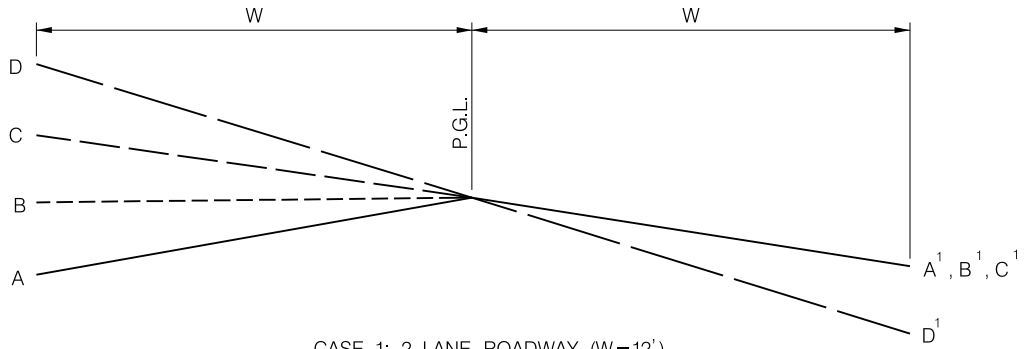

- CASE 1: 2 LANE ROADWAY (W=12')
- CASE 2: 4 LANE ROADWAY (W=24')
- CASE 3: 6 LANE ROADWAY (W=36')

CROSS SECTION

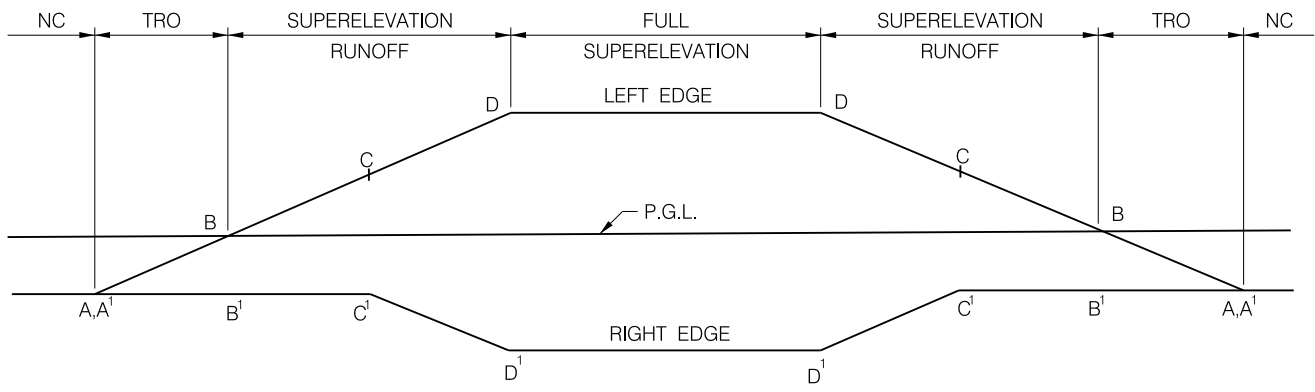

EDGE PROFILES

LEGEND

- P.C. - POINT OF CURVATURE
- P.T. - POINT OF TANGENCY
- TRO - TANGENT RUNOUT
- P.G.L. - PROFILE GRADE LINE
- NC - NORMAL CROWN

APPENDIX E.1

HOWARD COUNTY, MARYLAND  
DEPARTMENT OF PUBLIC WORKS

METHOD OF ATTAINING  
SUPERELEVATION  
(CASE 1, 2, & 3)

DRAWN BY:	WRA
CHECKED BY:	WRA
SCALE:	NO SCALE
DEC. 2017	



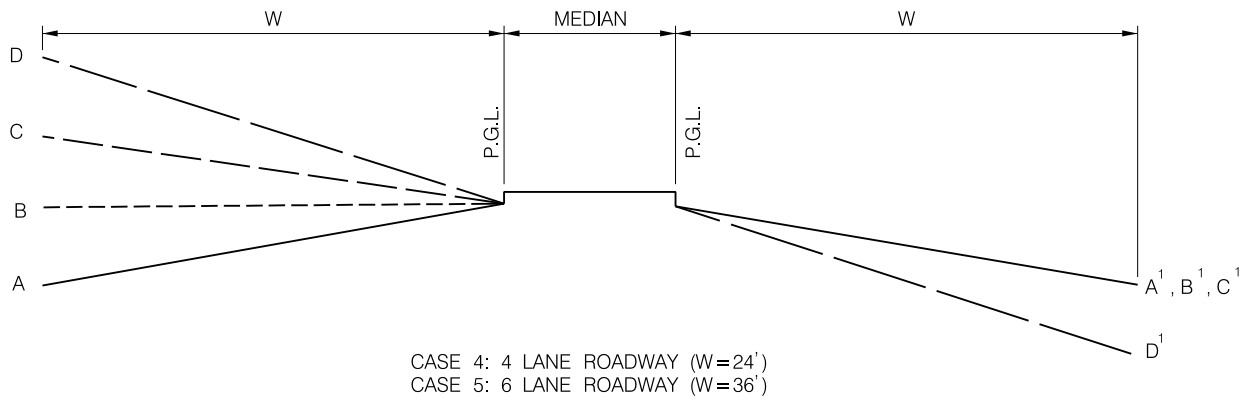
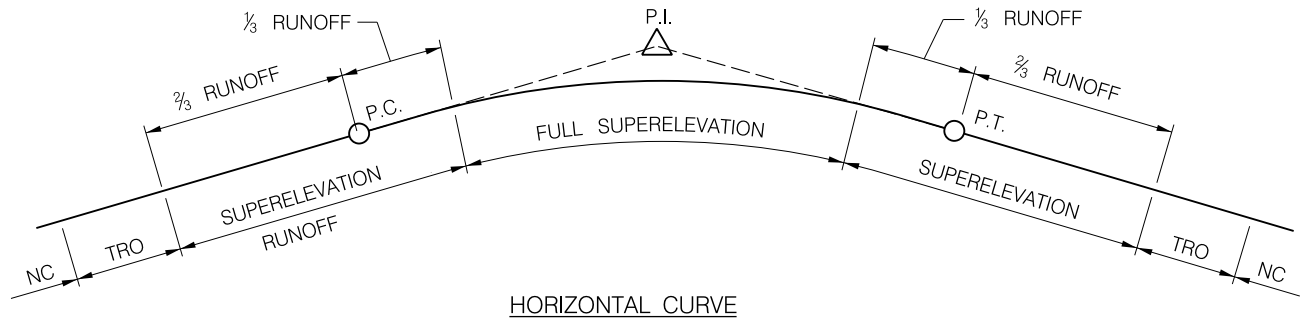

CROSS SECTION

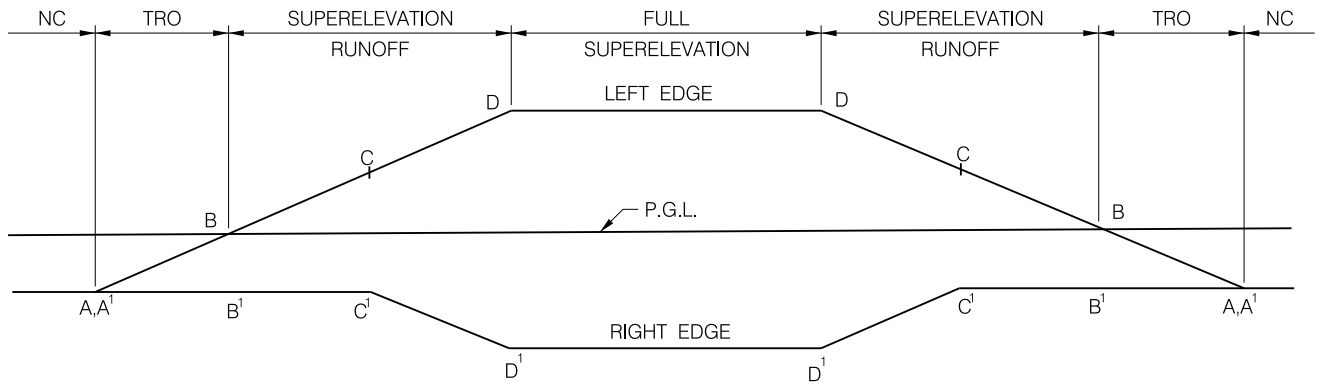

EDGE PROFILES

LEGEND

- P.C. - POINT OF CURVATURE
- P.T. - POINT OF TANGENCY
- TRO - TANGENT RUNOUT
- P.G.L. - PROFILE GRADE LINE
- NC - NORMAL CROWN

APPENDIX E.2

HOWARD COUNTY, MARYLAND  
DEPARTMENT OF PUBLIC WORKS

METHOD OF ATTAINING  
SUPERELEVATION  
(CASE 4 & 5)

DRAWN BY:	WRA
CHECKED BY:	WRA
SCALE:	NO SCALE
DEC. 2017	

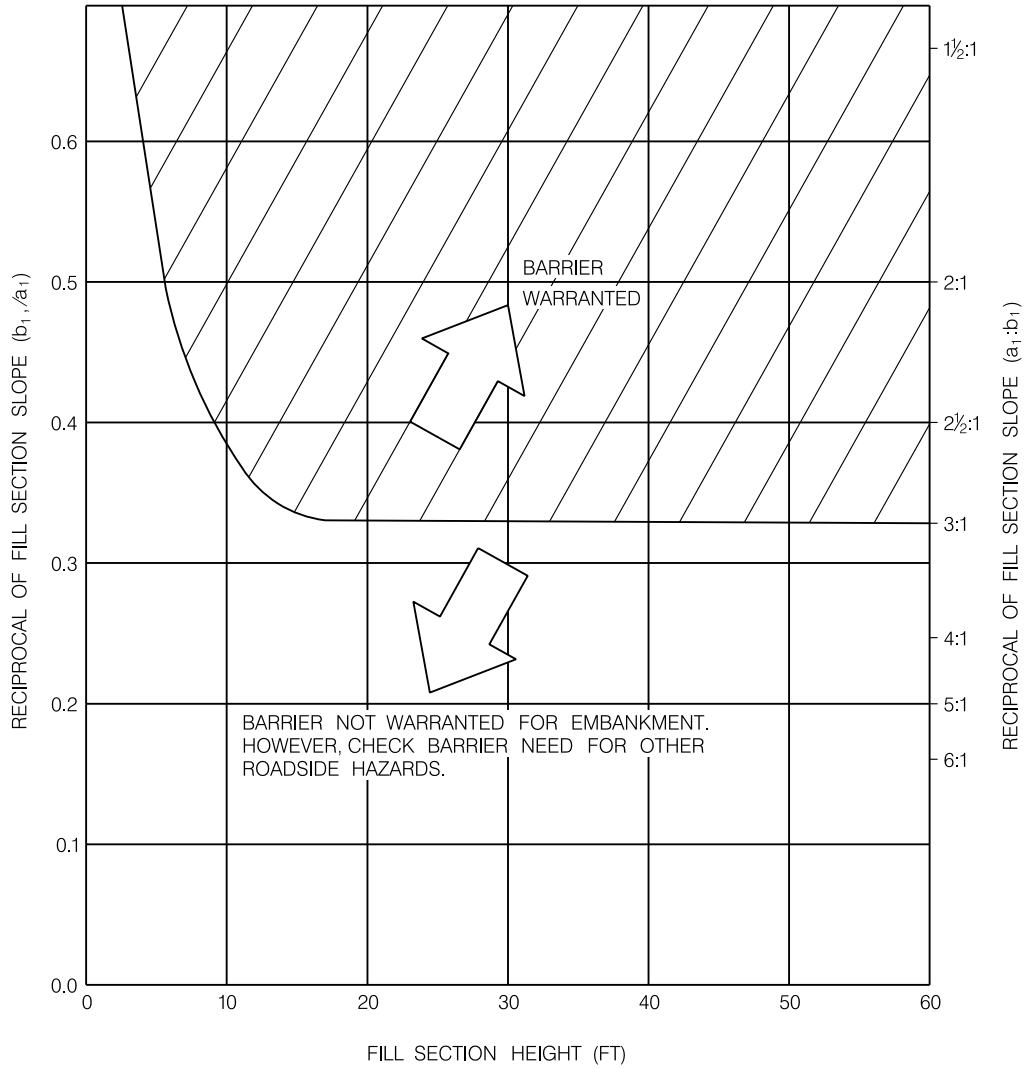
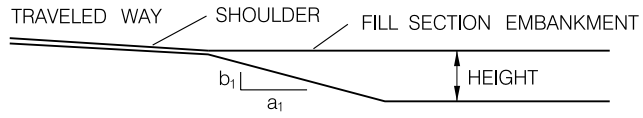

APPENDIX F

HOWARD COUNTY, MARYLAND  
DEPARTMENT OF PUBLIC WORKS

TRAFFIC BARRIER REQUIRED FOR  
EMBANKMENT GEOMETRY

DRAWN BY:	WRA
CHECKED BY:	WRA
SCALE:	NO SCALE
DEC. 2017	

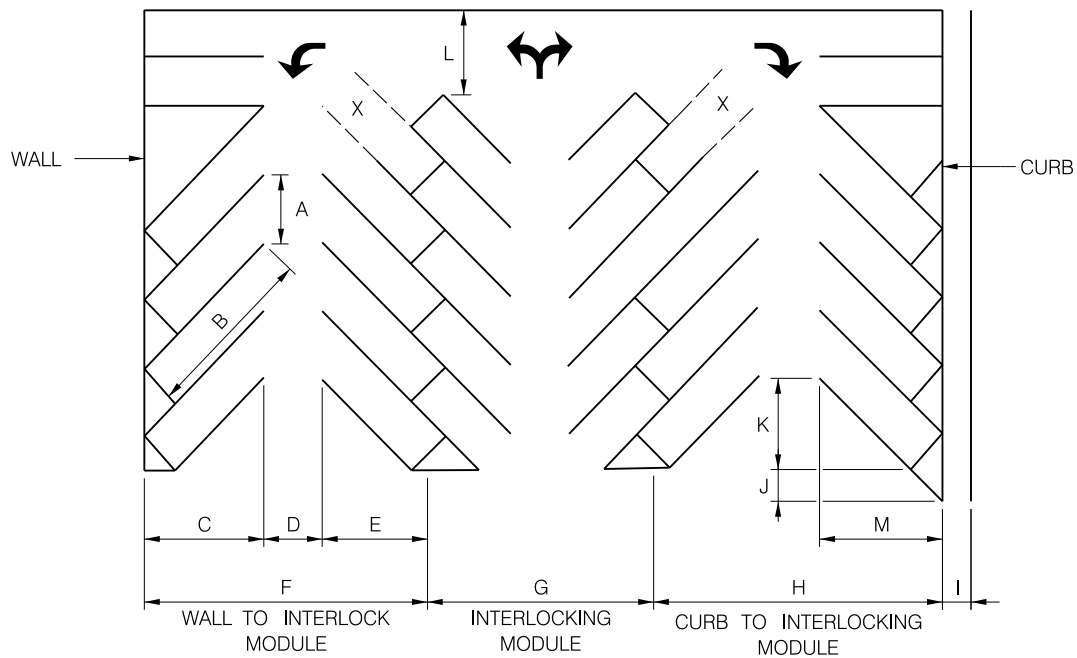

X - STALL NOT ACCESSIBLE IN CERTAIN LAYOUTS

DIMENSION	ON DIAGRAM	45°	60°	75°	90°
STALL WIDTH, PARALLEL TO AISLE	A	12.7	10.4	9.3	9.0
STALL LENGTH OF LINE	B	27.0	23.2	20.4	18.0
STALL DEPTH TO WALL	C	19.1	20.1	19.7	18.0
AISLE WIDTH BETWEEN STALL LINES	D	16.0	18.0	23.0	24.0
MODULE, DEPTH TO INTERLOCK	E	15.9	17.8	18.6	18.0
MODULE, WALL TO INTERLOCK	F	51.0	55.9	61.3	60.0
MODULE, INTERLOCK TO CURB FACE	G	47.8	53.7	60.1	60.0
MODULE, CURB FACE TO INTERLOCK	H	51.0	55.9	61.3	60.0
BUMPER OVERHANG (TYPICAL)	I	2.0	2.3	2.5	2.5
OFFSET	J	6.4	2.6	0.6	0.0
SETBACK	K	12.7	9.0	4.7	0.0
CROSS AISLE, ONE WAY	L	16.0	16.0	16.0	16.0
CROSS AISLE, TWO WAY	L	24.0	24.0	24.0	24.0
STALL DEPTH (TO CURB FACE)	M	19.1	20.1	19.7	18.0

**NOTES:**

1. THE MINIMUM REQUIREMENTS SET FORTH IN THE ZONING REGULATIONS SHALL BE COMPLIED WITH.
2. SEE SECTION 2.9 FOR REQUIREMENTS RELATING TO PARKING SPACE DESIGN FOR THE HANDICAPPED.
3. PARALLEL PARKING STALLS SHALL BE A MINIMUM OF 8' X 22' WITH A MINIMUM ADJACENT AISLE WIDTH OF 12 FEET, (24 FEET IF TWO-WAY).
4. THIS FIGURE BASED UPON A STALL WIDTH OF 9 FEET.
5. THE ABOVE DIMENSIONS MAY VARY AS PROVIDED IN A RECORDED FINAL DEVELOPMENT PLAN FOR A NEW TOWN DISTRICT.

APPENDIX G

HOWARD COUNTY, MARYLAND  
DEPARTMENT OF PUBLIC WORKS

PARKING STALL  
LAYOUT ELEMENTS

DRAWN BY: WRA  
CHECKED BY: WRA  
SCALE: NO SCALE

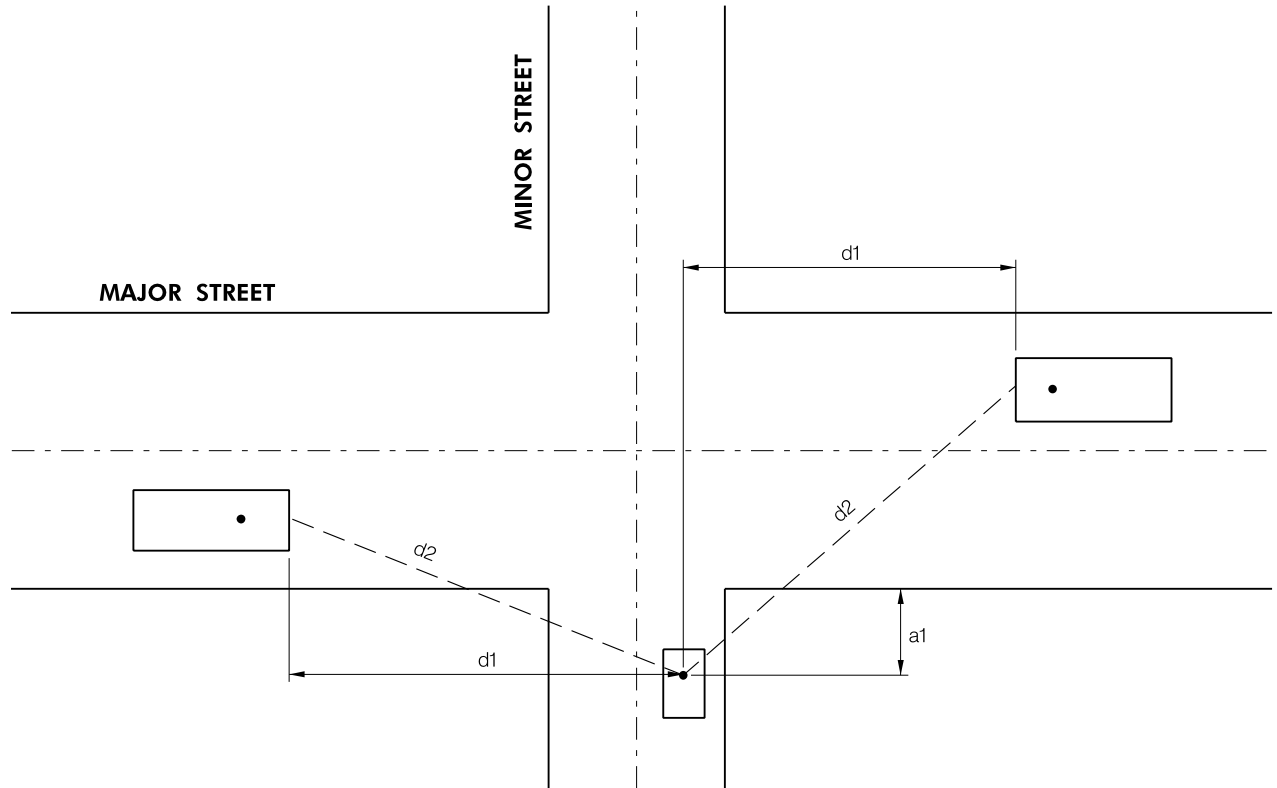

a1 = POSITION OF EYE ON MINOR STREET, 10' BACK FROM EDGE OF PAVEMENT OR FLOWLINE

d1 = STOPPING SIGHT DISTANCE (MIN.), RESIDENTIAL AREAS  
 HEIGHT OF EYES = 3.5'  
 HEIGHT OF OBJECT @ CENTERLINE OF INTERSECTION = 2.0'

d2 = UNOBSTRUCTED VIEW FROM MINOR STREET  
 HEIGHT OF EYE = 3.5'  
 HEIGHT OF OBJECT @ MAJOR STREET = 2.0'

APPENDIX H

HOWARD COUNTY, MARYLAND  
 DEPARTMENT OF PUBLIC WORKS

INTERSECTION SIGHT DISTANCE  
 IN RESIDENTIAL AREAS WHEN MAJOR STREET  
 CLASSIFICATION IS EQUAL TO OR LESS  
 THAN A MINOR COLLECTOR

DRAWN BY: WRA

CHECKED BY: WRA

SCALE: NO SCALE

DEC. 2017

**Introduction**

When Howard County adds new sidewalk segments on public property along county roads the community benefits from improved safety and walkability. Adjacent property owners also benefit from the infrastructure improvements, however, they should also be aware of the maintenance responsibilities.

These guidelines provide the procedure for communication with adjacent property owners regarding new sidewalk segments on public property along county roads, replacing the 1999 report “Sidewalk Extensions in Established Residential Neighborhoods Policy”. The new guidelines support the vision and goals of the [Howard County General Plan](#), the [Howard County Pedestrian Master Plan](#) and the [Howard County Complete Streets Policy](#) and are intended to result in more positive outcomes in terms of communication to property owners, improved walkability, pedestrian safety, and quality of life in Howard County.

**Process For Community Notification or Approval**

The chart below will be used for new sidewalks on public property along county roads.

Scenario		Process
1	Sidewalk segment is identified in current Pedestrian Master Plan.	Adjacent property owners are <b>notified</b> of the new sidewalk segment, but their approval is not required. Project description, community benefit and adjacent property owner maintenance responsibilities must all be included in the notification.  For scenarios 1, 2 and 4, Howard County Department of Public Works will send notification by certified mail to adjacent property owners at least 5 weeks before construction. Notice of construction to the public is generally 2 weeks before construction. Additional communication with adjacent property owners earlier in the process will be conducted as appropriate to ensure adequate awareness of County activity.  For scenario 3, the developer will send notification to the adjacent property owners and Howard County Department of Planning and Zoning (DPZ) by certified mail prior to submission of the original mylars that show design of the sidewalk to be constructed. DPZ will upload a copy of this notification and certified mail receipt to the PDox exhibit folder.
2	Sidewalk segment is within walking distance of a Howard County Public School, as defined by <a href="#">Howard County Public School System Policy 5200</a> .	
3	Sidewalk segment is an extension requested by Howard County Government as part of a development project.	
4	Sidewalk segment has been identified by the Office of Transportation as required for safe access to a transit stop, commercial or institutional use, use, park, sidewalk, pathway, or other public facility. The Office of Transportation will update this list on an annual basis by July 1 of each year.	
5	Sidewalk segment does not meet any of the criteria in 1 through 4 above.	Property owner <b>approval</b> by the following process is required. Local community must express their support through a community vote to be administered by Howard County. There will be one vote per property on the affected street. All property owners on the affected street within one quarter mile of the new sidewalk will be provided the opportunity to vote. Two Thirds majority support of the households that submit a vote is required as expression of community support.

**NOTES:**

- 1) Sidewalk segments in scenario 5 with community support will be considered through a prioritization process for the annual capital budget. Prioritization Process is being developed as part of Complete Streets Implementation in 2020. The Office of Transportation and Department of Public Works will work together to identify the properties to be included in the vote based on the parameters above and make adjustments based on the location of each project.
- 2) For all scenarios, sidewalk segments proposed on private property, or requiring disturbance to adjacent private property for its construction, will go through the existing easement process.
- 3) Sidewalk segments that are part of capital projects for roadway improvements are excluded from this process and will continue to go through the community engagement process for capital projects.

# CHAPTER 3

## Design of Bridges, Retaining Walls, and Small Structures

### 3.1 INTRODUCTION

A. Responsibility of the Designer .....	3-1
B. Limitation of Topics Presented in the Design Manual .....	3-1
C. Abbreviations .....	3-1
D. Definitions .....	3-1

### 3.2 GENERAL FEATURES OF DESIGN

A. Coordination with Road and Street Planning ...	3-2
B. Design Specifications.....	3-2
C. Technical Reference for Design.....	3-2
D. Basic Information Required for Design .....	3-2
E. Selection of Retaining Wall Type .....	3-3
F. Selection of Bridge Type.....	3-4
G. Selection of Culverts .....	3-6
H. Structures Over Waterways .....	3-6
I. Clearances.....	3-7
J. Bridge Roadway Section.....	3-8
K. Horizontal and Vertical Alignment.....	3-9
L. Subsurface Investigations.....	3-9
M. Foundation Reports .....	3-10
N. Scour Reports.....	3-10
O. Bridge Inspection .....	3-11
P. Design Life.....	3-11

### 3.3 DESIGN LOADING – HIGHWAY STRUCTURES

A. General .....	3-12
B. Dead Load .....	3-12
C. Live Load .....	3-12
D. Wind Loads.....	3-12
E. Thermal Forces.....	3-12
F. Force of Stream Flow.....	3-12
G. Earth Pressure.....	3-13
H. Earthquake Forces.....	3-13
I. Distribution of Loads .....	3-13
J. Constructability .....	3-13

### 3.4 SUBSTRUCTURES AND RETAINING WALLS

A. Retaining Walls.....	3-14
B. Abutments.....	3-27
C. Piers.....	3-29
D. Foundations .....	3-30
E. Substructure Protection .....	3-31
F. Slope and Bank Protection .....	3-31

### 3.5 BRIDGE SUPERSTRUCTURE

A. Slab on Beams and Girders.....	3-32
B. Beams and Girders.....	3-32
C. Steel Beams and Girders.....	3-33
D. Prestressed Concrete Beams .....	3-33
E. Bridge Drainage.....	3-33
F. Expansion Joints.....	3-33
G. Bearings.....	3-33
H. Drainage Troughs .....	3-34
I. Elevations .....	3-34
J. Sidewalks.....	3-34

### 3.6 SHARED USE PATH BRIDGES

A. General.....	3-35
B. Loading.....	3-35
C. Clearances.....	3-35
D. Profile and Grade.....	3-36
E. Railings and Fencing .....	3-36
F. Lighting .....	3-36
G. Aesthetics/Structure Type.....	3-36
H. Hydraulics.....	3-36

### 3.7 SHARED USE PATH UNDERPASSES

A. General.....	3-37
B. Clearances.....	3-37
C. Profile and Grade.....	3-37
D. Fencing.....	3-37
E. Lighting .....	3-38
F. Aesthetics .....	3-38
G. Drainage .....	3-38

### 3.8 BOX CULVERTS

A. Analysis .....	3-39
B. Design Guidelines.....	3-39
C. Bottomless Box Culverts (Rigid Frames).....	3-40

### 3.9 PIPE CULVERTS

A. Geometry.....	3-41
B. End Treatment.....	3-41
C. Foundation Requirements .....	3-43

### 3.10 UTILITIES ON BRIDGES

A. Telephone Lines & Cable .....	3-44
B. All Other Utilities .....	3-44

### 3.11 REHABILITATION OF EXISTING STRUCTURES

A. Introduction.....	3-45
B. Superstructure Repairs.....	3-46
C. Substructure Repairs .....	3-50
D. Retaining Walls.....	3-51
E. Maintenance of Traffic.....	3-51

### 3.12 LOAD RATINGS

A. Introduction.....	3-52
B. Methodology .....	3-52
C. Posting.....	3-52

### 3.13 PLAN PREPARATION GUIDELINES

A. Introduction.....	3-53
B. Sheet Layout and Order .....	3-53

### 3.14 REFERENCES .....



## 3.1 Introduction

### A. Responsibility of the Designer

This chapter addresses the selection and use of design and evaluation criteria and practices applicable to the design and maintenance of Public Works structures including bridges, retaining walls and small structures in Howard County. The subject matter presented herein includes specifications and guidelines for the selection, analysis and design of Public Works structures and their individual subcomponents. While the requirements described for the various aspects of design will include and cover the majority of conditions encountered, there is no intention to relieve the Designer of the responsibility to recognize when conditions are not favorable for the application of these design guidelines. The Designer shall be continually alert to those conditions that cannot be satisfied by the application of these design guidelines.

The design specifications to be used for various types of Public Works structures are identified and referenced herein. Guidance and interpretations of the design specifications and specific standard design requirements of the Bureau of Engineering are also presented in this Chapter.

### B. Limitations of Topics Presented in the Design Manual

It is not possible to include in this manual all features and topics of design and drafting necessary to accomplish the development of structure designs and construction documents for all projects incorporating bridges, retaining walls and small structures. The topics addressed herein are limited to those that will assist the Designer in performing most engineering design tasks in an efficient manner and comply with currently accepted engineering practice as well as Howard County practice. Although it is the Designer's responsibility to exercise professional judgment in the acceptance and/or use of the design guidelines included herein, the Designer shall recognize that they are being provided to assist in the development of the project in the manner preferred by Howard County. However, projects that are funded by Federal and/or State Aid may require compliance with the design criteria and standards set forth by the funding agency.

Projects may also be subject to current, future and evolving regulations set forth by various local state and federal regulatory and resource agencies which may require deviation with or expansion of the criteria and standards herein. Any deviations from these design guidelines shall be brought to the attention of Howard County immediately. Any waivers of this design manual shall be justified to Howard County in writing, from an engineering evaluation, and shall include relevant considerations of life cycle costs and/or maintenance requirements. Approval or denial of the waiver requests will be by return letter signed by the Chief of the Bureau of Engineering.

### C. Abbreviations

For standard abbreviations, refer to Section 1.2, "Abbreviations," of this design manual.

### D. Definitions

**Bridge:** A structure designed to carry vehicular, pedestrian and/or bicycle traffic having a roadway surface comprised of a structural element such as reinforced concrete or timber.

**Culvert:** A structure designed to carry vehicular, pedestrian and/or bicycle traffic having a roadway surface placed atop earthen fill and/or a structure designed as a continuous unit between the superstructure and substructure.

**Small Structure:** Any bridge or culvert structure that measures less than 20' clear between abutments (measured parallel to the roadway centerline).

**Retaining Wall:** Any structure that is built to retain a fill section or a roadway as a means to eliminate or minimize impacts to adjacent properties or structures, with greater than 3'-0" exposed. For retaining walls with less than 3'-0" exposed, refer to the Subdivision and Land Development Regulations.

## 3.2 General Features of Design

### A. Coordination with Road and Street Planning

Bridges, small structures and retaining walls are required for grade separations, stream crossings and earth retention usually as elements of a road or street facility. Planning and design of these structures must be coordinated with the road or street planning for overall project purpose as well as agreement in alignment, grade and typical section. For structures in historic districts and along scenic roads, aesthetics are also important.

### B. Design Specifications

#### 1. AASHTO

For bridges, retaining walls and small structures, the basic design specifications to be used are those of the latest edition of the "LRFD Bridge Design Specifications" of the Association of State Highway and Transportation Officials (AASHTO, Ref. 1), including subsequent interim specifications. Shared use path bridges and shared use path underpasses shall be designed in accordance with the AASHTO "Guide for the Development of Bicycle Facilities." (Ref. 23) and the AASHTO "Guide for Planning, Design and Operation of Pedestrian Facilities (Ref. 27).

#### 2. AREMA

The basic specifications to be followed in the design of railroad bridges or walls retaining railroad embankments are the current specifications of the American Railway Engineering and Maintenance-of Way Association (AREMA, Ref. 2).

#### 3. Howard County Storm Drainage Design Manual

Hydrologic and hydraulic design of structures shall be in accordance with the "Howard County Storm Drainage Design Manual Volume I" (Ref. 7).

4. Maryland Department of Transportation, State Highway Administration, Office of Structures (MDOT SHA OOS) Manual for Hydrologic and Hydraulic Design

Scour analyses and countermeasure design shall also be in accordance with the MDOT SHA OOS "Manual for Hydrologic and Hydraulic Design" (Ref. 12).

### C. Technical References for Design

#### 1. Capital Projects

Capital projects will be designed using Maryland Department of Transportation State Highway Administration Office of Structures Structural Guidelines and Procedure Memorandums (Ref. 10) Structural Details Manual (Ref. 11), and the Aesthetic Bridges - Users Guide (Ref. 26)

#### 2. Other Projects

Other projects, such as Developer Projects, shall be designed similarly as Capital Projects unless written authorization is granted by the Chief of the Bureau of Engineering.

### D. Basic Information Required for Design

#### 1. General Information

To determine the overall configuration of a structure, the Designer must obtain or establish the project alignment, profile and typical section and impose them on the existing physical topography.

#### 2. Studies and Reports

Previous studies, engineering reports and preliminary plans, if any, shall be reviewed before beginning any new work on the project.

#### 3. Record Plans

Records of utilities, existing structures, stream flow, and subsurface investigations at or near the proposed structure must be obtained.

#### 4. Topography

Existing topographic maps such as those available from the United States Coast and Geodetic Survey and the Howard County Department of Public Works may be used for preliminary studies. Hydrologic studies shall be based upon the best available topographic mapping. Existing mapping must be supplemented by aerial photogrammetry and/or ground surveys to provide adequate detailed topography at the project site.

### E. Selection of Retaining Wall Type

The type of retaining wall to be constructed usually is determined by the cost of construction. However, some other factors such as critical clearances or right-of-way cost may affect the decision. The most economical type of wall to construct is primarily a function of the height of the wall. A gravity type wall is the most economical for low walls, a cantilever type wall for intermediate heights and a counterfort type for high walls. Other factors that shall be considered in the comparison of alternate wall types are the lateral earth pressure, the type of foundation, the depth of piles, and the allowable bearing pressure. The simplicity of construction and the durability of a gravity wall must also be considered in the final decision. See Section 3.4.A.1 for a description of retaining wall types.

In the historic districts and on scenic roads the aesthetics of a stone facing, colored and impressed concrete brick or wood trim may merit consideration. The approval of aesthetic amenities and/or special landscaping shall be subject to the review and approval by Chief of the Bureau of Engineering.

#### 1. Proprietary Walls

Proprietary walls are patented systems for retaining soil. Depending on conditions, they can be more economical when compared to conventional retaining wall types. These walls are often more economical for long abutments and where high wall heights are dictated by field conditions. This type of wall construction can also save on bridge superstructure costs by reducing span lengths.

The detailed design and associated drawings are the responsibility of the proprietary wall firm, and wall products are typically provided through licensed regional manufacturers. The Maryland State Highway Administration requires that proprietary walls considered for use on capital projects must be on the list of Approved Proprietary Retaining Walls provided in the MDOT SHA Structural Guidelines and Procedure Memorandums (Ref. 10).

#### a. MSE

Mechanically stabilized earth (MSE) walls are comprised of a reinforced soil mass and modular precast concrete facing panels which are vertical or near vertical. MSE walls may be used where conventional gravity, cantilever, or counterforted walls are considered, and are well suited for supporting fills and where substantial total and differential settlements are anticipated. The precast facing panels are adaptable to a variety of architectural finishes. MSE walls should not be used where utilities other than highway drainage would be constructed in the reinforced soil zone, where erosion or scour may undermine the reinforced soil zone, or where galvanized reinforcements may be exposed to surface or ground water contaminated by pollutants characterized by low pH and high chlorides or sulfates.

#### b. Precast Gravity

Precast gravity walls, also known as segmental or modular retaining walls, consist of interlocking, soil-filled concrete units, and depend on dead weight for stability. The precast units can also be used with soil reinforcements to construct taller walls than those that resist loads by gravity alone. The stacked prefabricated units offer fast, easy installation, with the flexibility of curved and corner alignments and terraced walls. The concrete units may be colored and the wall face fabricated in a variety of shapes and textures.

Precast gravity walls should not be used on curves with a radius of less than 800 ft unless the curve can be substituted as a series of chords, or where the longitudinal differential settlement along the face of the wall is greater than 1/200.

c. Gabions

Gabions are stacked, stone-filled wire baskets that are interconnected to form gravity-type walls. Gabion walls are simple to install and are well suited for use as slope protection, low-height retaining walls and, in some cases, channel linings. They are permeable, which allows for backfill drainage and also permits the growth of natural vegetation. Once vegetation has been established, these walls blend well into the natural environment. Gabion walls are inherently flexible and are able to tolerate differential settlement that may result from unstable foundation soils. Consideration as a stream channel lining or stream bank stabilization technique shall only be made after considering the potential for debris lodging which can damage and accelerate failure of gabions. Due to their rough surface, gabions are not to be used where people may be walking or bicycling adjacent to the face of the wall.

## F. Selection of Bridge Type

### 1. Site Conditions

Since no two bridge sites are exactly equivalent, the Designer must develop a particular span arrangement and bridge type for each individual site. Conditions at the proposed site such as existing grading, type of crossing and subsurface conditions must be taken into consideration. The constraints of limited right-of-way are relevant to some sites. Bridges in historic districts and on scenic roads should be designed to preserve or enhance the appearance of the road and to afford views from the bridge.

### 2. Materials

The type of material to be used in construction will depend on a variety of factors including suitability of material to load requirements, availability of material, construction procedures, maintenance of traffic, construction time, unusual site conditions and relative life cycle cost of the various types of materials. The County precludes the use of prestressed concrete voided box beams or slab beams/panels without the expressed written permission of the Chief of the Bureau of Engineering due to the difficulty in maintaining these types of structures. Wooden bridges in County park property may be acceptable subject to the review and approval by both the Chief of the Bureau of Engineering and Director of the Department of Recreation and Parks.

### 3. Cost

Since the relative economy of structure types cannot be generalized, it will be necessary to prepare economic comparisons of alternate bridge types suitable for a given situation in order to determine which type is most suitable from a cost standpoint. Future maintenance costs should be considered in addition to initial costs to ensure that the structure with the lowest life cycle cost is used.

To prepare these economic comparisons, it is first necessary to determine the structure quantities that are associated with each type of bridge. These may be obtained from preliminary designs, from quantity charts, from historical data, or by a combination of these methods.

Unit prices for application to the estimated quantities should be determined based on recent bid tabulations for comparable projects in the Howard County area. These unit prices must be adjusted by judgment on the basis of project size, location and construction difficulties.

#### 4. Safety and Aesthetics

Important considerations are safety and aesthetics. Maximum traffic safety is provided by deck type overpass structures with adequately designed safety barriers and open span underpass structures without piers or other structural elements adjacent to the roadway.

Bridges on scenic roads or in historic districts merit special design consideration. The width of the deck should be consistent with the adjacent roadway. Barrier parapet walls should incorporate open railings at passenger eye level to permit views of the river crossing and adjacent scenery. Abutment embankments/slopes and piers shall be positioned to retain the natural stream channel adjacent to the bridge. If erosion is of concern, consider bio-engineering rather than riprap, gabions or a concrete channel.

Wider sidewalks for pedestrian use or scenic views, wider bicycle facilities, open railings, architectural treatments, and special lighting should be considered where it is appropriate to improve the utility and appearance of the bridge to make it more compatible with the other elements of the surrounding community, especially in historic districts along a scenic road. Modest use of special treatments can be done without a significant increase in cost, but such aesthetic requirements as an increase in span lengths, special finishes and special structural shapes can result in significant cost increases. The added cost resulting from special treatments must be evaluated to determine that the improved aesthetics are worthy of the increased cost.

#### 5. Maintenance Requirements

Future maintenance is another important consideration in the design of new bridges and existing bridge rehabilitations. All bridge components must be accessible for routine biennial inspection as well as maintenance, either by a snooper or some other means. Designs should provide for superstructure jacking to facilitate servicing, repair, or replacement of bridge bearings.

Key items to minimize future maintenance include:

- Minimize the number of expansion joints.
- Design sealed joints to prevent deck runoff from draining onto the bearings and beam seats below.
- Provide joint components that can be maintained.
- Avoid unusual joint details.
- Avoid details that trap dirt in splices, joints or other components.
- Locate scupper outlets below the bottom flange of beams to prevent water damage from splash-back.
- Provide downspouts and/or splash blocks where scupper outlets would cause erosion or dump water on roadways from overpasses.
- Eliminate or minimize the existence of deck drainage systems. If required, design deck drainage systems with sufficient size and adequate slope to prevent clogging and ponding. Provide clean-outs and avoid sharp bends in piping.
- Protect stream channels from erosion and piers and abutments from scour.
- Provide roadway drainage at abutments and wing walls to prevent erosion.
- Provide adequate vertical and horizontal clearances to prevent vehicle damage.
- Consider the feasibility of painting structural steel and evaluate the suitability of weathering steel.
- Consider using precast prestressed concrete structural members.
- Investigate the feasibility of using integral or semi-integral abutment construction.

## G. Selection of Culverts

### 1. General

Culverts are generally cost-effective solutions for relatively small stream crossings. A single culvert can be used for the smallest crossing. Larger stream crossings can utilize multiple cell box culverts or a battery of pipe culverts. In each case, all factors of hydraulics, topography, economics and environmental factors must be considered before a culvert alternative is selected. It will be necessary to comply with the policies of all permitting agencies concerning the need for permits and the maintenance of the natural environment. Design of culverts shall meet all the requirements of bridges, including those for foundation design and scour design. For small culverts with inverts, subsurface borings taken for the roadway will usually be sufficient for the foundation design.

Box culverts are generally made of concrete with mild reinforcing. These can be cast in the field or precast at a factory in units which are then shipped and placed in the field. When precast concrete box culverts are used, the box culvert ends and all wing walls, headwalls and toe walls shall be cast in place; refer to Volume IV Design Manual.

Pipe culverts are available in a large range of shapes, sizes and materials. Steel pipes can consist of pipes rolled at the mill such as corrugated metal pipes (CMP's, etc.) or pipes made from steel plates assembled at the job site such as structural steel plate pipes (SPP's, etc.). Steel pipes less than 4' in diameter may be either the CMP or the SPP type. Steel pipes larger than 4' in diameter must be of the SPP type.

Culverts without paved inverts, such as structural plate pipe arches and precast concrete arches, are also commonly available. These types of structures are very dependent on the foundation conditions and their use may require extensive foundation and scour investigation work.

Refer to Volume I Design Manual for additional information concerning culverts.

### 2. Advantages

For streams of a size within the hydraulic capacity of a culvert, the culvert is usually less costly to design, construct and maintain than a bridge. A culvert structure is less susceptible than a bridge to structural defects due to differential settlement, undermining and scour.

### 3. Disadvantages

In most cases, culverts tend to have the following disadvantages:

- The design opening is wider than the existing channel requiring undesirable channel modifications.
- Silting occurs during low flow.
- Multiple cells tend to obstruct flow and accumulate debris during flood flow.
- Water velocity increases in the culvert cause downstream scour.

## H. Structures over Waterways

### 1. Hydrologic Studies

Hydrologic studies shall be performed for all structures crossing waterways. Flow rates and hydrographs associated with these studies shall be developed in accordance with procedures described in the "Howard County Storm Drainage Design Manual," Vol. I (Ref. 7) for typical roadway culverts or the MDOT SHA "Manual for Hydrologic and Hydraulic Design" (Ref. 12) for Small Structures or Bridges. Existing stream gauging data, observed high water marks and observations of local residents shall be used to check and calibrate hydrologic calculations based on empirical methods, including those noted in Reference 12.

### 2. Hydraulic Studies

#### a. Bridges

Analysis of the effect of bridges on the stream flow and establishment of the design high water at the bridge site or at other critical points shall be in accordance with the procedures described in the MDOT SHA OOS "Manual for Hydrologic and Hydraulic Design" (Ref. 12).

A freeboard of one (1) foot from the design high water to the underside of the superstructure shall be maintained. Refer to the "Howard County Storm Drainage Design Manual" (Ref. 7) for specific freeboard requirements.

b. Box Culverts

The effects and characteristics of flow in box culverts shall be analyzed in accordance with the procedures described in the Federal Highway Administration Circular "Hydraulic Design of Highway Culverts" (HDS-5) (Ref. 8) or similar publications. Due consideration shall be given to both inlet control and outlet control.

3. Hydraulic Design Criteria

a. Highwater Elevation

A stream crossing structure shall be designed to interfere as little as possible with the natural stream channel and shall conform to the "Howard County Storm Drainage Design Manual", Vol. I (Ref. 7) and other State and Federal requirements.

b. Maximum Velocities

Discharge velocity shall be consistent with channel materials. For maximum and minimum velocities, refer to the "Howard County Storm Drainage Design Manual," Vol I (Ref. 7), the MDOT SHA OOS "Manual for Hydrologic and Hydraulic Design" (Ref. 12) and applicable environmental regulations.

4. Walking and Bicycling Use

Consideration shall be given to making provisions for walking and bicycling under structures placed over waterways. Where feasible, provide sufficient clearance for walking and bicycling use in these circumstance in accordance with the relevant sections of this chapter. In these locations, the Designer shall consider the pavement section and subgrade if they could be subjected to flooding and/or erosion.

I. Clearances

1. Horizontal Clearances - Highways

a. Bridge Roadway Width

The roadway width of bridges shall preferably be the full width of the approach roadway section including the shoulders. Minimum bridge roadway widths are discussed in the MDOT SHA "Structural Guidelines and Procedure Memorandums" (Ref. 10) for various classifications of highways. These minimum widths shall be adhered to unless written authorization is provided by the Chief of the Bureau of Engineering.

If sidewalks and/or bicycle facilities exist on either approach roadway section, or are anticipated within the bridge's service life, those sidewalks and/or bicycle facilities shall be carried across the bridge. If sidewalks and/or bicycle facilities are not anticipated within the bridge's service life, an eight-foot shoulder shall be provided on each side of the bridge to provide accommodation for people walking and bicycling.

b. Underpass Clearance

For an open section roadway or a bridge, the piers or abutments shall be set to provide clearance for the full shoulder plus a guardrail or concrete barrier. The roadway face of the guardrail shall be at least 5'-0" from the face of the pier or abutment. The face of the guardrail or barrier shall be at least 2'-0" outside of the normal shoulder line. For closed section roadways, the face of pier or abutment shall be set a minimum of 8' -0" back of the curb line. Piers and abutments shall be protected by guardrail or crash walls.



If sidewalks and/or bicycle facilities exist on either approach roadway section, or are anticipated within the bridge's service life, piers or abutments shall be set to provide sufficient horizontal clearance to allow for accommodation of those facilities. If sidewalks and/or bicycle facilities are not anticipated within the bridge's service life, piers or abutments shall be set to accommodate a minimum eight-foot shoulder on each side of roadway under the bridge to provide accommodation for people walking and bicycling.

## 2. Horizontal Clearances - Railroads

Horizontal clearances from railroad tracks to piers, abutments or walls of an overpass structure shall be in accordance with the requirements of AREMA (Ref. 2) and the policy of the particular railroad for the class of track involved. In the case of privately owned spurs, the clearances shall be at least equal to the requirements of the Maryland Public Safety Laws and meet the approval of the railroad operating over the spur.

## 3. Vertical Clearance

### a. Highways

Vertical clearance to highway or railroad structures over highways shall be 16'-9", which provides for 16'-0" minimum over any usable portion of the roadway and shoulder and 9" of future surfacing.

### b. Railroad

Vertical clearance over railroads shall be 24'-3" (top of rail to underclearance) for electrified railroads, and 23'-0" for all others. Clearance shall be approved by the railroad owner.

## c. Shared Use Path Bridges

Vertical under clearances for shared use path bridges shall be: 24'-3" over electrified railroads and 23'-0" over other railroads.

Vertical clearances for shared use path bridges over streets or highways shall be in accordance with the requirements of AASHTO (Ref. 1) and provide an additional 1'-0" clearance over that required for highway bridges.

## J. Bridge Roadway Section

### 1. Curbed (Closed) Section

The flow line of a curbed roadway section shall be continuous across the bridge.

### 2. Rural (Open) Section

The shoulder of a rural section shall be carried across the bridge. The cross slope configuration shall conform to that of the approach roadway except that the cross slope in the shoulder area on the bridge shall be an extension of the adjacent traffic lane (i.e., no shoulder breaks on bridge). The approach roadway shoulder slope shall be transitioned to meet the shoulder slope of the structure beginning at a minimum distance of fifty (50) feet from the ends of the structure.

### 3. Barriers

All barriers on bridges and approaches, including transitions, shall meet or exceed MDOT SHA and AASHTO specifications, including crash testing requirements based on the roadway classification. The MDOT SHA "Bridge Railing Manual" (Ref. 25) provides guidance on railing selection and shall be adhered to for capital projects unless written authorization is provided by the Chief of the Bureau of Engineering. Selection of the appropriate barrier, with or without metal railing, should be made with consideration given to the type of roadway facility (controlled access or non-controlled access) and type of pedestrian and bicycle facilities on the bridge. The Designer shall use care in selecting railing systems to ensure serviceability.

Safety fence shall be provided in accordance with MDOT SHA requirements. Decorative barriers/railings or bridge lighting appurtenances shall be subject to the approval of the Chief of the Bureau of Engineering.

In accordance with the AASHTO "Guide for the Development of Bicycle Facilities" (Ref. 23), the minimum recommended distance between a shared use path and the roadway curb (i.e., face of curb) or edge of traveled way (where there is no curb) on a vehicular bridge is 5 feet. Where the separation is less than 5 feet a physical barrier or railing should be provided between the path and the roadway. The barrier or railing shall be in accordance with the provisions of AASHTO (Ref. 1 and Ref. 23) for a pedestrian, bicycle, or combination railing. A barrier or railing between a shared use path and adjacent roadway should not impair sight distance at intersections and should be designed to limit the potential for injury to errant motorists and bicyclists.

Careful attention shall be given to the treatment of railings at bridge ends. Exposed rail ends, posts and sharp changes in the geometry of the railing shall be avoided. A smooth transition by means of a continuation of the bridge barrier, flared end posts, roadway guardrail anchored to the bridge barrier, continuation of bridge guardrail, or other effective means shall be provided to protect the traffic from direct collision with the bridge rail ends and to afford protection for people walking and bicycling. Guidelines for these transitions are specified in the MDOT SHA "Book of Standards for Highway and Incidental Structures" (Ref. 15).

## K. Horizontal and Vertical Alignment

### 1. Bridges

The horizontal and vertical alignment of the bridge must be coordinated with the overall plan and profile of the approach roadway. Geometric design requirements concerning sight distances, minimum curve radii, superelevation, etc., shall be in accordance with Chapter 2, "Road and Street Design." Methods and criteria for maintenance of traffic are contained in Chapter 5, "Traffic Studies."

## 2. Horizontal Alignment of Box Culverts

### a. Alignment with Waterway and Road

Culverts shall generally be located and aligned as closely as possible to the natural drainage course for which they are being designed. The skew angle shall be kept as close to 0 degrees as possible, while providing a minimum stream relocation, if any.

### b. Maintenance of Flow

The Designer must consider the requirements for maintaining stream flow during construction. It may be necessary to provide a temporary channel in order to provide for maintenance of flow. Maintenance of stream flow plans shall be prepared in accordance with the latest edition of the MDE "Maryland Waterway Construction Guidelines" (Ref. 9).

## L. Subsurface Investigations

In order to determine the type of foundation and allowable bearing pressures, borings will be required at the proposed locations of walls, culverts and bridge foundations. The information obtained should include elevation of the existing ground at the boring, a description and depth of the material encountered, number of blows per six (6) inches on the sampling spoon, recovery of cored rock, total depth of boring, the water table level and the time of observation. For small culverts with inverts, subsurface borings taken for the roadway will usually suffice for the foundation design.

Standard penetration borings through soil are required to be performed in accordance with AASHTO T206 and ASTM D1586. The number of blows required for each 6 inches of penetration or fraction thereof shall be recorded. The first 6-inch penetration is considered to be a seating drive. The number of blows required for the second and third six inches of penetration added together is considered the penetration resistance, N.

Split spoon samples shall be taken at every change in material at intervals not exceeding five (5) feet. All borings should be drilled to refusal and cored a minimum of 5 feet into rock. Refusal is defined as 50 blows or more per inch or less of penetration.

Foundation borings shall generally be located as follows: one boring at each end of each substructure unit for multibeam bridges; one boring at each end minimum with intermediate borings as required to maintain 100' maximum c/c spacing for culvert type structures and retaining walls.

All the boring log information must be shown on the plans.

#### **M. Foundation Reports**

A formal Foundation Report is required for all retaining walls 4' or greater in height measured from the top of wall to the ground line at the front face of wall; all box culverts; all pipe culverts with individual spans greater than 8' measured perpendicular to the pipe; all hydraulic structures without inverts; and all bridges. For structures not meeting these requirements the Designer shall perform sufficient subsurface investigations and analysis to ensure the stability of the structure. The depth and number of borings shall be in accordance with AASHTO LRFD Bridge Design Specifications requirements.

The formal foundation report shall provide all information and calculations documenting that the subsurface investigations and foundation design have been made in accordance with the requirements of this Volume III Design Manual and AASHTO LRFD Bridge Design Specifications. In addition, the foundation report shall address the impact of settlement of approach fill embankment on bridge foundation design as well as pertinent foundation construction control and construction considerations. The Foundation Report shall be accompanied by boring logs plotted on a plan sheet and preliminary structure plans.

For all new or replacement bridges, detailed Foundation Reports shall be prepared for review and approval by the Chief of the Bureau of Engineering. Foundation Reports shall include copies of all boring and laboratory testing information including a project map noting the location of all test borings. For Capital Projects, Foundation Reports shall be prepared in accordance with applicable sections of the MDOT SHA "Structural Guidelines and Procedure Memorandums" (Ref. 10).

#### **N. Scour Reports**

Current regulations require that the construction, replacement or rehabilitation of any bridge structure which uses either full or partial funding from the Federal Government be accompanied by an approved Scour Analysis Report. Reports for such projects will be reviewed by the Maryland State Highway Administration Office of Structures (OOS). All scour reports shall be developed in accordance with the MDOT SHA OOS "Manual for Hydrologic and Hydraulic Design" (Ref. 12), in particular Chapter 11.

All scour reports shall be prepared and sealed by a registered professional engineer in the state of Maryland. Personnel involved in the evaluation of scour need to possess the technical qualifications, including practical experience, education and professional judgment, to perform the individual tasks assigned. Interpretation of results and conclusions of scour analyses shall be accomplished by registered engineers qualified in the appropriate disciplines. Because of the complexity of bridge scour, the evaluations shall be performed by an interdisciplinary team of engineers with the requisite knowledge in structural, hydraulic, river mechanics and geotechnical engineering.

For non-federally funded projects, scour reports may not be required if any of the following criteria applies:

- The project scope is limited to the rehabilitation of the bridge superstructure and/or minor rehabilitation of the substructure. Minor rehabilitation of the substructure shall be limited to abutment (or pier) repair and shall not include any changes to the overall geometry of the substructure units, with the exception of minor fascia treatments that do not reduce the total waterway opening by more than 10%.

- The project is a replacement or rehabilitation of a bridge or bottomless culvert where evidence of scour is minimal either through inspection or previous inspection reports and where the proposed abutment footings, or deep foundations such as piles, are founded in non-erodible rock. Rock where borings indicate a Rock Quality Designation (RQD) less than 50% shall be assumed to be erodible (FHWA Memorandum on Scourability of Rock – June 19, 1991).
- The project is a new, replacement or rehabilitated bridge or culvert along a private road or drive not governed by any county, state or local municipality easements, right-of-way or right-of-entry.

The county reserves the right to request that a formal Scour Report be prepared in accordance with MDOT SHA standards for any project within county right-of-way or along a roadway maintained by the county by virtue of easement, right-of-entry or prior agreement. A formal Scour Report shall be required for all bridges and small structures without integral paved inverts and which carry waterways. A formal Scour Report shall also be required for retaining walls which could be subject to stream action and which require a formal Foundation Report. The Scour Report shall be submitted in conjunction with the Foundation Report. The county may also request that a Scour Report be prepared for a structure for the purpose of re-evaluating the Structure Inventory and Appraisal Item 113. If a Scour Report is not requested by the county, the engineer of record shall still have the responsibility of ensuring that the bridge or culvert is designed in adequate consideration of the effects of scour.

Contraction, abutment and pier scour depths/elevations developed by scour analyses shall be used in the assessment of the bridge stability in accordance with Chapter 11 of the MDOT SHA OOS “Manual for Hydrologic and Hydraulic Design” (Ref. 12). For the Design Flood for scour, the material in the resulting scour prism shall be assumed to be removed, and the bridge shall be analyzed with stability factors as dictated by the AASHTO “LRFD Bridge Design Specifications” (Ref. 1). For the Check Flood for scour, the material in the resulting scour prism shall be assumed to be removed and the bridge shall be analyzed with a stability factor of 1.0.

## O. Bridge Inspection

Howard County maintains an inventory of bridges and small structures. To assist the County, Designers are required to provide the following information for culverts with spans greater than 10’ and for all bridges:

- Design Storm Year
- Runoff Q in cfs
- Drainage area in acres
- High Water Elevation for the Design Storm
- Year of Maryland State Highway Specification used
- Year of AASHTO Specification used

## P. Design Life

All bridges must be designed to achieve a minimum service life of 75 years or a longer period (e.g., 100 years), if so directed by the Chief of the Bureau of Engineering, for applicable capital projects.

### 3.3 Design Loading – Highway Structures

#### A. General

Loads and loading combinations shall be in accordance with the provisions of AASHTO (Ref. 1). The limit states described in the AASHTO specifications (Ref. 1) shall be investigated for the design and analysis of bridge components.

#### B. Dead Load

##### 1. Future Wearing Surface

In addition to the dead load of the structure, an allowance shall be made in the design analysis for a future wearing surface. This shall be 25 lbs./sq. ft. for all except moveable spans and exceptionally long spans. The additional deck load for these spans shall be determined on an individual basis depending on the type of construction.

##### 2. Unit Loads on Culverts

The dead load on culverts shall include the dead load of the box and the weight of earth above the box. Loads shall be calculated in accordance with AASHTO Specifications, (Ref. 1). Except for box culverts on piles, the dead load of the bottom slab and water within the box should be neglected in design of slabs and walls. These dead loads shall, however, be included when determining foundation pressures. In the absence of more exact information, the density of the soil shall be taken as 120 lbs./cu. ft. and 150 lbs./cu. ft. shall be used for the weight of the concrete.

##### 3. SIP Forms

An additional allowance shall be made in the design analysis when the use of steel stay in place forms is required. This loading shall be 15 lbs./sq. ft. of deck form plan area. This value includes the weight of the forms plus concrete in the corrugation valleys of the forms.

#### C. Live Load

##### 1. Design Loadings

For vehicular bridges and all other structures, an HL-93 loading shall be used. For additional information concerning Design Loadings, see the MDOT SHA “Structural Guidelines and Procedure Memorandums” (Ref. 10). Permanent deformations under overloads, live load deflections, and fatigue characteristics under service loadings shall be investigated, as specified in the AASHTO Specifications (Ref. 1). The loading for temporary structures will be determined by the Department of Public Works on the basis of the duration of time the temporary structure is expected to be in place and the anticipated traffic characteristics during that period. It shall not be less than HS-20 with standard over-load provisions, as specified in the AASHTO Specifications (Ref. 1).

#### D. Wind Loads

Wind loads calculated in accordance with AASHTO Specifications (Ref. 1) shall be applied to the bridge substructure and superstructure as indicated therein.

#### E. Thermal Forces

Thermal forces shall be as specified by AASHTO (Ref.1) for moderate climate.

#### F. Force of Stream Flow

The effect of flowing water on piers shall be calculated in accordance with AASHTO (Ref. 1).

No static or dynamic pressures shall be applied for ice floes, ice sheets or ice jams except under special circumstances for public structures such as pedestrian bridges in public parks. The consideration of occasional cost and safety must be considered in the structure's life cycle cost and this determination shall be made by the Chief of the Bureau of Engineering.

## G. Earth Pressure

Structures which retain earth shall be proportioned to withstand pressure as given by Rankine's formula. In the absence of more specific information, an equivalent fluid pressure of 35 lbs./cu. ft. shall be used. This pressure is based on the assumption that a layer of porous backfill and a drainage system with weep holes will be provided to insure a low ground water elevation at the rear face of the structure.

If conditions are such that it is not possible to control the water table behind the structure, the structure shall be designed taking into account, below the water level, the full hydraulic pressure in conjunction with pressures of the submerged soil.

A sloping finished grade line behind the structure may be accounted for by computing the pressure on the basis of the depth of earth in a vertical plane at the heel of the footing.

### 1. Water Pressure

If conditions are such that it is not possible to control the water table behind the structure, the structure shall be designed taking into account, below the water table, the full hydraulic pressure in conjunction with pressures of the submerged soil. Below the water table the unit weight of the retained soil is reduced to its submerged or buoyant value. As a result, the lateral earth pressure below the water table is reduced, while the retained water exerts a horizontal hydrostatic pressure.

When ground water levels differ on opposite sides of a retaining wall, the upward buoyant force beneath the wall foundation tends to overturn the wall. Unequal ground water levels also result in seepage beneath the wall. The effect of seepage forces is to increase the load on the back of the wall (and decrease any passive resistance in front of the wall). Pore pressures in the backfill soil can be approximated through the development of a flow net or other analytical methods, and then added to the horizontal earth pressures acting on the wall.

## H. Earthquake Forces

Structures shall not be designed to resist earthquake forces.

### I. Distribution of Loads

For distribution of loads refer to AASHTO (Ref. 1).

### J. Constructability

Constructability checks shall be completed in accordance with the provisions of the AASHTO Specifications (Ref. 1). The wind load provisions specified in the "Guide Specifications for Wind Loads on Bridges During Construction" of the Association of State Highway and Transportation Officials (AASHTO, Ref. 22), including subsequent interim specifications shall be used for wind loading on steel and concrete superstructures before the deck has been placed.

The load factors for construction loads shall be taken as the minimum specified in AASHTO (Ref. 1).

### 3.4 Substructures and Retaining Walls

#### A. Retaining Walls

The primary structural function of a retaining wall is to counteract the lateral forces caused by earth pressure. These forces have two principal effects on the wall. First, they tend to overturn the wall and secondly, these forces tend to push or slide the wall. Before designing specific parts of the wall, such as the footing, stem, etc., overall stability of the wall and the earth mass must be satisfied. The total earth mass containing the wall and its foundation must be in equilibrium. A subsurface investigation should be made to determine the possibility of a slip plane failure that would affect the global stability of the entire installation. The overturning moment about the toe of the footing, caused by the earth pressure and surcharge, must be resisted by the stabilizing moments of the dead load forces. Unless a structure is keyed into rock or is restrained by an adjacent structure, the horizontal earth pressure force must be resisted by friction between the footing and the foundation. Retaining walls used in subdivisions and site development plans shall use the retaining wall checklist when submitting designs.

Reinforced fills and proprietary retaining walls will be considered on a case by case basis. No consideration for use shall be given unless the system has been approved for use by the MDOT State Highway Administration.

Retaining walls are primarily either fill walls or cut walls. Fill walls are typically constructed from the bottom up and consist of placing material behind the face of the wall. Cut walls are typically constructed from the top down and consist of removing material in front of the face of the wall.

#### 1. Fill Retaining Wall Types

There are six principal types of fill retaining walls: gravity walls, semi-gravity walls, cantilever walls, counterfort walls, buttress walls and MSE walls. Table 1 provides general guidelines for fill retaining wall selection.

##### a. Gravity Walls

Gravity Walls resist sliding and overturning by means of their mass, the resultant of all forces being within the middle third of any horizontal section through the wall. Reinforcing is required only to resist shrinkage and temperature forces and shall be the minimum required by the governing design specification.

As a guide for initial design, the width of the base of the wall should be approximately 0.45 times the total height. The final size used varies with the type of material, the slope of the backfill surface, the surcharge and the allowable bearing pressure.

**TABLE 3-1  
FILL RETAINING WALL TYPES**

Retaining Wall Type	Cost Effective Height Range (ft)	Typical Required Right-of-Way	Tolerable Differential Settlement
Concrete Gravity Wall	Up to 10 feet	0.5 – 0.7H	1/500
Concrete Cantilever Wall	Up to 20 feet	0.4 to 0.7H	1/500
Concrete Counterfort Wall	30 feet to 60 feet	0.4 – 0.7 H	1/500
Gabion Wall	5 feet to 20 feet	0.5 – 0.7H	1/50
MSE wall with precast facing	10 feet to 40 feet	0.7 to 1.0H	1/100
MSE wall (modular block facing)	5 feet to 20 feet	0.7 to 1.0H	1/200
MSE wall (geotextile/ geogrid/ welded wire facing)	5 feet to 40 feet	0.7 to 1.0H	1/50



Gravity walls may be used under any condition where foundation material is reasonably good and are often the most economical type for use where the wall is quite low. Because of its massive construction, this type of wall is more resistant to destructive agents and partial disintegration of the concrete is not as serious as for the heavily reinforced types.

b. Semi-Gravity Walls

By introducing a relatively small amount of reinforcing steel in the back face of a gravity wall, a slenderer stem can be used. This type of wall is commonly known as a semi-gravity wall. The semi-gravity wall is more economical than the solid gravity wall and has the same advantage of durability due to massive construction, although to a lesser extent.

c. Cantilever Walls

Cantilever walls consist of a continuous stem supported on a continuous footing. Resistance to overturning results from the stabilizing action of the weight of concrete in the wall and the block of earth supported directly over the heel of the footing. The stem, the heel of the footing and the toe of the footing act as cantilever slabs resisting the applied loads.

The stem shall be designed to resist the moments and shears caused by the earth pressure above the top of footing and the surcharge applied to it. The weight of the stem itself shall be considered and the critical sections designed for direct stress and bending.

The heel of the footing shall be designed to resist its own weight and the total weight of the earth supported directly on it, with or without a reduction for upward foundation pressures.

The toe shall be designed to resist the foundation pressure acting on it, less its own weight, but no reduction is to be made for backfill over the toe.

Cantilever walls are the most widely used type and can be used in heights to approximately 30 feet. This type of wall is by nature more flexible than the other types, and considerable deflection can be expected at the top of the higher walls. Consequently, cantilever walls should not be tied to other types of walls with shear keys. Rather, architectural offsets or pilasters should be incorporated into the design at such junctures so that differential deflection will not be noticeable.

For the most economical arrangement, a cantilever wall stem should be located over the point where the resultant of the loads pierces the plane of the footing. This means the toe of the footing for the typical wall should be about one-third the total width of the footing. However, the stem may be located anywhere on the footing as required by right-of-way requirements, conflict with structures and utilities, or for other reasons.

As a guide for initial design, the footing width normally ranges between 0.5 and 0.7 the total height of the wall, depending on allowable bearing pressures, desirable bearing differentials and superimposed loads.

d. Counterfort Walls

Counterfort walls consist of a face wall spanning continuously between counterforts which extend into the backfill. Counterforts are spaced at some constant interval, usually in the range of from 8 feet to 16 feet and are supported on either individual or continuous footings.

The face wall may be either full height or, in the case of deep footings, extend only 2 ± feet below finished grade at the front of the wall.

Face walls shall be designed as continuous slabs in increments of height. Each increment shall have the proper thickness and/or reinforcement to resist the average earth pressure over that increment. If the face wall is tied to the footing, the bottom increment can be designed for vertical and horizontal bending.

The heel portion of continuous footings shall also be designed as continuous slabs. The toe, which commonly is rather short, shall be designed as a cantilever as previously described. Counterforts shall be designed as tee- beams to resist the overturning forces for the full counterfort interval.

Counterfort walls are usually most economical for heights over 30 feet and in instances where the footing must be placed very deep.

Widths of counterfort footings to satisfy stability requirements are usually at least 0.5 the height of the wall. The heel dimension is normally governed by the counterfort design.

It is necessary that counterforts be of sufficient size to permit proper placing and vibrating of the concrete and to permit proper cleaning prior to placing the concrete. They should not be less than 2 feet in thickness.

#### e. Buttress Walls

A variation of the counterfort wall is the buttress wall. This type of wall resembles the counterfort wall except that the members supporting the face slab are on the exposed face of the wall and are called buttresses rather than counterforts. The face slab is designed in the same manner as a counterfort wall and the buttresses are designed as rectangular beams. Since the buttresses are exposed and therefore reduce the clearance in front of the wall, the buttress wall is rarely used.

#### f. MSE

Mechanically stabilized earth (MSE) walls consist of facing elements connected to layers of soil reinforcement that are embedded within a select backfill. These walls resist lateral loads through the dead weight of the reinforced soil mass behind the wall facing. Wall heights of up to 40 ft can be constructed. MSE walls are often used at bridge abutments, with a stub abutment supported on piles behind the wall.

MSE wall systems are designed to meet the requirements for overall stability (global stability), external stability including overturning and sliding, bearing capacity, and settlement, as well as the internal stability requirements including the strength of the reinforcement element, pullout resistance and connection strength. Lateral pressures are determined from active earth pressure acting on the back of the reinforced soil mass. The analysis of the overall and external stability is the responsibility of the design consultant. The analysis of the internal stability is the responsibility of a proprietary retaining wall company.

The reinforced soil mass consists of select granular backfill placed in layers between reinforcement, which is comprised of either inextensible (deformation of the reinforcement at failure is less than deformability of soil – includes steel strip and bar mat reinforcement) or extensible (deformation of reinforcement at failure is comparable to or greater than deformability of soil – includes geogrid, geotextile and woven steel mesh reinforcement) reinforcement. Metallic reinforcement typically consists of mild steel and nonmetallic reinforcements typically consist of polymeric materials consisting of polyester or polyethylene. Steel soil reinforcements and connection hardware shall be galvanized. The soil reinforcement length is a minimum of 70 percent of the overall wall height and is uniform throughout the entire height of the wall.

Facing elements are designed to resist the horizontal force of the reinforcement. Facing materials consist of precast concrete panels, full height panels, modular block wall units, and welded wire mesh facing. Segmental, precast concrete panels are typically between 5 inches and 8 inches thick, 5 feet high and have a front face width that is 5 feet or 10 feet. Panels are typically square or rectangular; however, cruciform, diamond and hexagonal face geometry are also available. Typical dimensions of full-height concrete panels are 6 inches to 8 inches thick 8 feet to 10 feet wide. Modular block wall face units (also known as segmental retaining wall units) are typically 4 inches to 15 inches high, 8 inches to 18 inches in exposed face length and 8 inches to 24 inches in depth. Welded wire mesh facing is typically used for temporary walls. Galvanized steel is used for permanent walls with welded wire facing. Hot dip galvanizing of at least 2 oz/ft<sup>2</sup> is expected to protect the steel in atmospheric conditions for up to 50 years. A corrosion rate of 1.0 mil/year should be considered for temporary, non-galvanized steel facings.

Internal drainage must be provided to prevent saturation of the reinforced backfill and infiltration of damaging elements from the surface. In cut areas, drainage blankets are provided behind and below the reinforced soil mass. For roadways subject to chemical dicing agents, an impervious membrane above the first layer of reinforcement may be necessary.

General design guidelines for MSE retaining walls are as follows:

- Publication No. FHWA-NHI-10-024, Design and Construction of Mechanically Stabilized Earth Walls and Reinforced Soil Slopes, Volumes I and II, 2009
- AASHTO LRFD Bridge Design Specifications, Volume II

#### g. Precast Gravity

Prefabricated modular wall systems are designed to resist lateral earth loads as a gravity retaining wall. Two systems are generally used: interlocking soil filled concrete bins and segmental masonry concrete units. Soil filled bin systems can be used to construct walls up to 45 ft high. Segmental wall systems may be used to construct walls four to six feet high without soil reinforcements. They can also be used with soil reinforcements, typically metal or geosynthetic meshes, for wall heights up to 45 ft.

For overall stability against sliding and overturning, the modular units are considered to act as a rigid body. For overturning, 80 percent of the soil-fill unit weight within the modules is effective in resisting overturning moments, as not all of the soil can be expected to arch within the module. The full weight of the soil-fill may be considered to resist sliding. Stability shall be evaluated at every module level.

Modular units are installed on either concrete or gravel leveling pads, depending on soil conditions. Soil shall be sloped away from the wall base to prevent erosion and eliminate water from running along the wall base. Where groundwater behind the wall is expected, the backfill is typically drained with a continuous drainage blanket consisting of crushed stone immediately behind the wall and a continuous perforated drain pipe near the footing level. Additional subsurface drainage may be required behind reinforced soils. It is also important to provide adequate grading or drainage systems at the top of the wall to direct surface flows away from walls.

#### h. Gabions

Gabion walls are constructed from stone filled wire mesh boxes, which are stacked and wired together. The backfill can be placed behind the wall as each level of boxes is installed. Gabion walls can be economically constructed to about 30 feet in height. Gabions can also be used as a wall facing with soil reinforcements, typically galvanized wire mesh, for wall heights up to 45 feet.

Gabion boxes are constructed from hexagonal mesh woven from soft galvanized wire. The wire may be PVC coated to protect from acidic soils or marine environments. The nominal size of the mesh openings is three to four inches. The boxes are usually constructed with internal wire mesh diaphragms or wire cross-ties for increased strength. Standard gabions are available with the following dimensions:

- Nominal Length – 6, 9, or 12 feet
- Nominal Width – 3 feet
- Nominal Height – 1, 1.5, or 3 feet.

The stone used to fill the gabion baskets should be non-friable, weather resistant, and preferably high density. Gabions may be filled by hand or machinery, but in either case it is important that they be filled carefully to maintain the box shape to ensure proper alignment of the wall.

Gabion walls are designed to resist lateral earth loads as a mass gravity structure, in which the additional tensile resistance of the wire mesh is ignored. Gabion structures are permeable, allowing for free drainage, and are not designed for water pressure loads. While gabion walls are self-draining, it is advisable to provide a backfill drain above footing level to collect drainage and protect the wall foundation.

Smaller height gabions are used at the base of walls, and the boxes are arranged such that the longest dimension is perpendicular to the wall to reduce shear deformation. The front wall face may be either stepped or flush, but a stepped front face is preferable, especially for taller walls. Gabion walls are constructed tilted back toward the retained soil at about a 6-degree angle for stability.

#### i. Noise Abatement Walls

Noise Abatement Walls shall be designed and constructed in accordance with the MDOT SHA Noise Abatement Planning and Engineering Guidelines and Chapter 15 of the MDOT SHA OOS Design Guides for Capital Projects. All components shall meet or exceed the requirements set forth in these policies and guidelines and will be subject to the same level of review and design standard. Refer to Section 5.2.F of this Design Manual for additional requirements. General design guidelines and references for noise abatement walls are as follows:

##### FHWA Guidelines for Noise Abatement Walls:

- FHWA Highway Noise Fundamentals, 1980
- FHWA Highway Traffic Noise Sources, 1980
- FHWA Traffic Noise Model Technical Manual, 1998
- FHWA Measurement of Highway-Related Noise, 1996
- FHWA Highway Construction Noise: Measurement, Prediction; and Mitigation, 1977
- AASHTO Guide on Evaluation and Abatement of Traffic Noise, 1993
- FHWA Highway Traffic Noise Analysis and Abatement Policy and Guidance, 1995
- FHWA A Guide to Visual Quality in Noise Barrier Design, 1976
- FHWA Noise Barrier Design Handbook, 1975
- LPILE by Ensoft, Inc., Latest Version
- AASHTO Guide Specifications for Structural Design of Sound Barriers
- AASHTO LRFD Bridge Design Specifications

- FHWA Traffic Noise Model (TNM), Latest Version

MDOT SHA Guidelines for Noise Abatement Walls:

- AASHTO LRFD Bridge Design Specifications, 8th Edition, 2017
- Highway Traffic Noise: Federal Highway Administration - Analysis and Abatement Guidance, June 2010
- MDOT SHA Standard Specifications for Construction and Materials, July 2020
- MDOT SHA Highway Noise Abatement Planning and Engineering Guidelines – April 2020
- MDOT SHA Noise Barrier Standards
- MDOT SHA Pavement & Geotechnical Design Guide
- Guidance contained in any memos and letters published by the FHWA/MDOT SHA

Refer to the Subdivision and Land Development Regulations for residential noise abatement wall guidelines.

2. Cut Type Retaining Walls

There are four principle types of cut retaining walls: sheet pile walls, pile and lagging retaining walls, soil nail walls and permanent tieback retaining walls.

Table 2 provides general guidelines for cut retaining wall selection.

**TABLE 3-2  
CUT RETAINING WALL TYPES**

Wall Type	Cost	Effective Height Range (feet)	Required Right-of-Way
Sheet Pile Wall		Up to 16 feet	Minimal
Soldier Pile and Lagging Wall		Up to 18 feet	Minimal
Tieback Wall		15 feet to 45 feet	15 feet minimum unbonded length + anchor bond length
Soil Nail Wall		10 feet to 40 feet	0.6 to 1.0H

a. Sheet Pile Walls

Sheet pile walls are often used for support of excavation systems. These walls are constructed in one phase in which interlocking sheet piles are driven to the required depth below the final grade. These walls may not be feasible for construction in hard ground conditions or where obstructions exist due to potential difficulty obtaining the required embedment depth or potential problems maintaining proper alignment during installation.

Sheet pile walls act as both vertical and horizontal wall elements. Because these walls are relatively continuous, water pressure behind the wall must be considered in the design.

b. Soldier Pile and Lagging Walls

Soldier pile and lagging walls use discrete vertical wall elements that are spanned by lagging, which typically consists of timber. This wall system can typically be constructed in most subsurface conditions; however, cohesionless soils and soft clays may cause construction problems due to limited stand up time for lagging installation.

Vertical soldier beams may either be installed into predrilled holes or driven to their required depth. After installation of the soldier beams, the soil in front of the wall is excavated in lifts (typically 4 feet to 5 feet), followed by the installation of horizontal lagging. Once the lagging reaches the final depth, prefabricated drainage elements may be placed at predetermined spacings and connected to a collector at the base of the wall.

Support is provided through the shear and bending stiffness of the vertical wall element and passive resistance of the soil below the finished grade elevation.

### c. Tieback Wall (Anchored Wall System)

Tieback walls are retaining walls that utilize top down construction methods that consist of nongravity cantilevered walls with one or more levels of tiebacks (ground anchors) anchored to the ground to aid in stability.

Nongravity cantilevered walls consist of either discrete (soldier beam, typically piles or drilled shafts) or continuous (sheet piles) vertical wall elements that can be either driven or drilled to depths below finished grade. Support is provided through the shear and bending stiffness of the vertical wall element and passive resistance of the soil below the finished grade elevation.

Tiebacks consist of a steel rod, wire or tendons that are anchored in the ground by drilling a hole into the soil or rock behind the wall face and encasing a portion of the rod or tendons in a grout mixture that forms a bond with the surrounding soil or rock to provide lateral resistance to resist horizontal pressures acting on the wall. If a tendon is used, the wire is typically prestressed to a desired tension. The rod or tendon are typically inclined at an angle. The installation of tiebacks requires specialized equipment and construction methods and post-installation testing.

Tieback walls have the following advantages:

- Potential incorporation of temporary excavation support in the permanent retaining wall;
- Reduction of construction disturbance and right-of-way acquisition required;
- Reduction of excavation needed when compared to other retaining wall systems;
- Adaptability to various site and subsurface conditions.

The following are some disadvantages of the wall system:

- Permanent underground easements are required;
- Groundwater drainage systems may be difficult to construct;
- Creep can affect long-term performance and displacements in clayey soils;
- Pull-out capacity may not be able to be economically mobilized in soft soils.

All production anchors shall be subjected to load testing and stressing in accordance with the provisions of AASHTO LRFD Bridge Construction Specifications.

Additional information on Tieback (Anchored) Retaining Walls can be found in:

- AASHTO LRFD Bridge Design Specifications, Volumes I and II (Ref. 1).
- Publication No. FHWA-IF-99-015, Geotechnical Engineering Circular No. 4, Ground Anchors and Anchored Systems, 1999.

### d. Soil Nail Walls

Soil nail walls are constructed using top down construction methods. In soil nail construction, the ground is excavated in 3 foot to 5 foot lifts. Soil nails and an initial shotcrete construction facing are placed at each lift to provide support prior to progressing to the next lift. A final cast-in-place (CIP) concrete facing is installed when the lifts are complete. Typical vertical and horizontal nail spacings are 3 feet to 6 feet. The vertical spacing is dependent on the height that the site soils can temporarily remain stable after excavation of each lift.

Typically, dense to very dense granular soils with apparent cohesion, weathered rock (depending on orientation of weakness planes), stiff to hard fine grain soils, engineered fill and residual soils that are above groundwater are ideal for soil nailing. Non-engineered fill and residual soils that contain mica or shale may pose difficult soil conditions for soil nailing. Poorly graded cohesionless soils, areas with high groundwater, soils with cobbles and boulders, soft fine-grained soils, corrosive soils or groundwater, expansive soils and karst conditions are generally not suitable for soil nail walls.

In general, the soil nails support the soil and transfer loads behind the wall. The construction shotcrete and final CIP facings support the soil between the nails.

A drainage system is installed behind the soil nail walls to direct groundwater away from the wall and collect perched groundwater and-or infiltrated surface water that is present behind the facing.

The following failure modes should be evaluated for the design of soil nail walls: internal stability, global stability (temporary at each lift and final stability), lateral sliding, nail pullout, nail tensile strength, and facing bending, punching shear and headed stud in tension.

Design procedures and requirements are provided in the following reference:

Publication No. FHWA-NHI-14-007, Soil Nail Walls Reference Manual, 2015

Verification and proof load testing are performed during construction. Verification load tests are conducted on sacrificial nails to verify the pullout resistance resulting from the Contractor's installation methods are consistent with the values of pullout resistance and bond strengths used in design. Proof tests are conducted on a minimum of 5% of the total production nails that are installed to verify that there are no significant variations in soil nail performance throughout wall construction.

### 3. Retaining Wall Design Guidelines

#### a. General Items

The purpose of these guidelines is to establish the minimum requirements necessary to provide plans and details for the construction of retaining walls in Howard County.

These guidelines shall be adhered to when practical and applicable, but the responsibility of providing a complete design ultimately belongs to the design engineer. Innovative designs are not meant to be discouraged by these guidelines. Common sense and good engineering judgment are essential elements of any good design.

In order to facilitate the review process, these guidelines are intended to promote consistency and expediency by standardizing the requirements that are necessary in order to provide acceptable retaining wall construction documents.

For new construction, the first preference is to revise grading so a retaining wall is not needed. To the extent feasible, if a wall is required, any pedestrian or bicycle facility at its base shall be widened by at least one foot to maintain an offset between facility users and the face of the wall.

Figure 3-1. Offset to Retaining Wall.

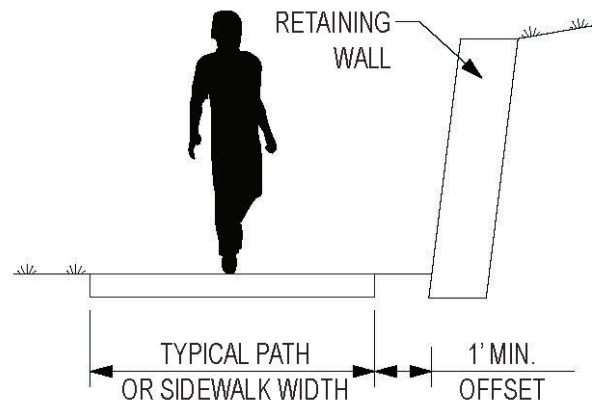



If a retaining wall exceeds three feet in height at any point, the following criteria will apply, otherwise it is exempt from review by the Development Engineering Division and only the Department of Inspections, Licenses, and Permits (DILP) and the Division of Land Development (DLD) regulations apply. The height of a retaining wall for this purpose is measured from the finished grade at the front of the wall to the top of the wall. Grades above or below the wall shall not exceed a 2: 1 slope.

All horizontal dimensions in the plan view shall be taken from the bottom face of the wall at the proposed grade.

Retaining walls shall not be constructed upon fill materials. Exceptions may be granted via the Design Manual Waiver Request process.

All retaining walls, regardless of height, shall not be constructed within a Howard County Right of Way or Easement. The only exception is if written permission has been granted by the Director of Public Works.

All construction documents for retaining walls three feet in height or higher shall be designed, signed, and sealed by a Registered Professional Engineer.

b. Construction Drawings – Plan Views

All retaining walls shall be shown in plan view showing all of the proposed conditions at a maximum scale of 1" = 50'.

Show enough grading around the retaining wall to clearly demonstrate all flow patterns in the vicinity of the retaining wall. Provide spot elevations every 50 feet along the length of the wall at the top and bottom of the wall.

Provide flow arrows along the top of the wall to indicate flow paths along the length of the wall. It is not desirable for run-off to be allowed to cascade over the top of retaining walls. This will be permitted if run-off approaching the wall is sheet flow and adequate scour protection is provided.

For all walls, a minimum ten-foot-wide construction easement/setback shall be required from the face of the wall. If the wall is greater than ten feet in height the width of the easement shall be equivalent to the height of the wall. This easement shall be clear of floodplains, buffers, wetlands, property boundaries, structures and/or other environmentally sensitive areas. 4:1 is the maximum slope allowed within this easement in front of the wall.

A permanent wall maintenance easement shall be provided behind each wall that is equivalent in width to the height of the wall plus the length of the geogrid. No structures may be placed within this easement.

For "CRITICAL" walls ten feet or more in height, the design engineer shall appropriately address the issue of global stability for the slope and provide an acceptable maintenance easement based upon the conclusions of the analysis.

For all block and timber retaining walls, a ten-foot-wide "NO TREE" planting zone shall be delineated behind the top of the wall.

Under no circumstances shall the maintenance easement for any wall encroach upon the building envelope of any residential lot.

c. Construction Drawings – Elevations

The elevation, or front view, of the proposed retaining wall is considered to be the most important detail for the purposes of constructing the wall.

The following scales are recommended, but good judgment is necessary to ensure that this detail is readable and reasonably drawn.

- VERTICAL: 1" = 1' to 1" = 5'; 1" = 2' preferred
- HORIZONTAL: 1" = 5' for lengths up to 50'
- 1" = 10' or as appropriate over 50' in length

Provide a vertical scale bar and horizontal stationing across the bottom of the elevation.

For the purpose of constructability, the front view shall have each typical section identified by a letter or a number. Provide section breaks shown as heavy vertical lines indicating where each section begins and ends. Variation from one section to the next should be minimized in order to reduce the number of typical sections.

Essential elements of the elevation are as follows:

- A complete outline of the wall
- Show the finished grade line superimposed over the wall at the top and at the bottom
- Show the locations of the weep holes (40' on center) and other utilities in proximity to the wall
- The vertical placement of the geogrid must be identified by which block layers the geogrid is to be inserted between
- Indicate the required allowable bearing strength for each typical section or as it varies
- Show with a dimension the maximum height allowed by design for each typical section

d. Construction Drawings – Cross Sections

Show a typical cross-sectional detail for each section of the wall as it varies by height and geogrid placement and/or other significant design features. The maximum vertical scale is 1" = 5'; 1" = 2' is preferred.

Show the maximum height of the wall for each typical section.

For block or timber walls, show the number of blocks or timbers, vertically placed, graphically.

For reinforced concrete walls, show the typical reinforcement design including notes to indicate proper horizontal spacing along the length of the wall.

Indicate the maximum slope above or below allowed by the design. The maximum slope allowed is 2: 1.

For each typical section show the allowable bearing strength that is required for the soil beneath the base of the wall

Show the drain placement behind the base of the wall, entrenched in stone for at least one foot of depth, then covered with filter fabric to prevent clogging. More stone should then be placed in a one foot wide vertical layer to 90% of the walls height to facilitate water flow to the drain. Weep holes must daylight through the wall every 40 feet.

Geogrid placement by layers and length for manufactured block walls must be shown in the cross sectional detail

e. Construction Details – Fences/Guardrails

Retaining walls that exceed thirty inches in height at any point and present an inherent falling hazard require a fence along the entire length of the wall.

The fence must be a minimum of thirty-six inches in height, and the openings in the fence or rail must be small enough to prevent the passage of a four-inch sphere. Fences adjacent to bicycle facilities have additional requirements and shall be designed in accordance with the AASHTO "Guide for the Development of Bicycle Facilities" (Ref. 23).

Fences must be stable enough to withstand 200 lbs. of concentrated loading applied horizontally at any point.

A typical footing detail shall be provided.

If the fence is set back from the face of the wall, the fence shall be tapered at the ends of the wall to prevent children from accessing the ledge.

If the fence is not directly above the wall, show its location in the plan view.

For walls in proximity to vehicular traffic, guardrails, per the Howard County standard guardrail details are required.

For roadways and parking lots, the face of the curb must be a minimum of two feet in front of the face of the guardrail or the retaining wall. The Howard County standard 7" curb is required.

The location of a guardrail, if required shall be three feet from the face at the top of the wall to the side of the guardrail facing the wall.

f. Design Calculations / Failure Analysis

All retaining walls shall be designed to resist the possible modes of failure, including sliding, overturning, and bearing failure. Sufficient analysis shall be provided to confirm that the resistance factors have been applied and that the design of the retaining wall meets AASHTO design specifications (Ref. 1).

Any likely or anticipated surcharge loads shall be included in the failure analysis. If none are included in the design, add a note to the cross-sectional details stating, "this wall is not designed for surcharge loads".

For manufactured block walls, supplemental design booklets may be submitted to satisfy the failure analysis requirement, but they may not be considered as part of the construction drawings. The plans shall contain all of the relevant information required to construct the wall.

For reinforced concrete walls, provide a complete set of design calculations for the wall, including the placement and spacing of steel reinforcement.

g. Construction Drawings – Required Notes

"Retaining walls shall only be constructed under the observation of a Registered Professional Engineer and a (NICET, W ACEL or equivalent) certified soils technician."

"The required bearing resistance beneath the footing of the wall shall be verified in the field by a certified soils technician. Testing documentation must be provided to the Howard County Inspector prior to the start of construction." The required test procedure shall be the Dynamic Cone Penetrometer Test ASTM STP-399."

"The suitability of fill material shall be confirmed by the on-site soils technician. Each eight-inch lift must be compacted to a minimum of 95% Standard Proctor Density and the testing report shall be made available to the Howard County Inspector upon completion of construction. "

"For "CRITICAL" walls, one soil boring is required every 100 feet along the length of the wall, copies of the boring reports shall be provided to the Howard County Inspector upon completion of construction."

All other miscellaneous information required for the construction of the retaining wall shall be included somewhere on the construction drawings. Items may include material specifications, recommendations from the manufacturer of block wall systems, notes from the design engineer, specific instructions for non-typical designs, etc.

Each design package shall include the Designer's seal and signature on the cover page along with the name, address, and telephone number of the consulting firm he represents. Also provide the name, address, and telephone number of the owner/developer.

h. Policy on Retaining Walls in Stormwater Management Facilities

The Howard County Design Manual Volume I requires under section 5.2.5.A.1. that "A pond buffer shall be provided for all stormwater management facilities in accordance with the criteria set forth in the MDE Design Manual. The minimum distance from the end of the outlet structure, including the riprap exit channel, or the edge of an underground facility, to the downstream property line shall not be less than 25 feet. Along other parts of the facility, the minimum distance from the toe of the embankment or top of cut to the property lines, public easements, rights-of-way, and structures shall be 25'. For structures adjacent to the facility where the top of cut cannot be defined and the grading condition encroaches onto a residential lot, the distance from the 100-year water surface elevation within the facility or edge of underground facility shall be 25 feet minimum horizontal and two feet minimum vertical to the lowest floor elevation of a habitable structure."

This specification applies for all new retaining wall construction plans to be submitted for review. Through the Alternative Compliance request procedure, the following provisions will govern.

In general, the Department of Public Works discourages the use of retaining walls in stormwater management facilities due to the increased maintenance costs and long-term liability of the structures. The Department recognizes, however, that in some instances retaining walls may be required as other viable alternatives may not be available. If the Department or its designee deems that retaining walls are the only viable solution within a stormwater management facility, the following criteria shall govern:

- 1) For all facilities, both public and private, retaining walls shall not be allowed within the embankment area, either inside or outside the facility, unless the toe of the retaining wall and any tie-backs are beyond the phreatic line of the facility. These walls shall have a height not to exceed three feet. Tiered walls shall not be allowed unless they are designed so that the influences of the upper walls do not impact the lower walls.
- 2) For publicly owned and maintained facilities or privately owned and jointly maintained facilities, minor retaining walls, less than three feet in height, measured from the top of the wall to the ground along the face, shall be allowed on cut slopes above the uppermost maintenance bench of any stormwater management facility. These walls shall not be located in the ponding area of the facility. These walls shall be privately owned and maintained. The construction and maintenance of these walls shall be made part of a developer agreement for the facility.
- 3) For privately owned and maintained facilities, the maximum height of any wall, whether single or tiered, shall not exceed ten feet. These walls may be located in or adjacent to pooling areas provided the walls are reinforced concrete and shall be designed to withstand the hydrostatic pressure and saturated ground conditions on the footing of a flooded condition.

- 4) All retaining walls in excess of thirty inches in height shall have an appropriate safety railing or fence.

i. Tiered Walls

For tiered walls where the total cumulative height of the tiers is ten feet in height or greater, the provisions for "CRITICAL" walls apply.

The set back from one wall to the next in a series of tiers shall be equivalent to the height of the lower wall or greater.

The slope between tiered walls shall not exceed 4: 1.

3. Wall Thickness

The thickness of the top of a wall shall be sufficient to accommodate any railing or appurtenance to be placed on it. However, for ease in placing concrete, it shall not be less than 1 foot.

4. Passive Pressure

Passive pressures on the front face of a wall are unpredictable and shall be neglected for normal wall footing depths. Shear keys shall be similarly avoided. Passive earth pressure shall not be considered in any case if the cover in front of the wall may be subject to scour or if the ground slopes at more than 4:1 rate.

5. Wall Elevations

Top of wall elevations shall be computed at joints and alignment breaks and at vertical curve control points. The elevation shall be tied to Howard County control where available within one mile.

6. Batter

For walls over 15 feet in height, consideration shall be given to provide a batter on the front face of wall. The back face of the wall shall be battered if required for the stem design.

7. Joints

Walls shall be detailed with expansion points through the portion above the footing at approximately 90 ft. intervals. Gravity, semi-gravity and cantilever walls shall have two equally spaced contraction joints located between the expansion joints. The face walls of counterfort and buttress walls are designed as continuous beams and they cannot have contraction joints within a continuous unit. Counterfort and buttress walls shall be designed in continuous units not over 60 feet in length with expansion joints between units.

8. Drainage and Weep Holes

Drainage systems should be provided behind retaining walls to reduce hydraulic pressures, which could result in failure of the wall. Retaining walls are typically drained by means of either continuous back drains or weep holes, along with porous backfill, which allows water to flow behind the wall. Weep holes extending through the wall stem with a pocket of gravel backfill on the back, are inexpensive, but often become clogged. Continuous back drains are preferable to weep holes and may be outlet into nearby storm drainage systems, if available, to minimize aesthetic impacts.

For retaining walls and larger wing walls, sloped perforated PVC pipe drains shall be placed along the back face of walls. The perforated pipe drains are placed below a full height porous backfill blanket and are supported on a continuous concrete ledge extending from the back of the wall. Drain outlets, consisting of 4 in. non-perforated PVC pipe, spaced at no more than 15 ft along the wall, are located 1 ft above the finished groundline at the front of wall. Outlet drain pipes are to be extended 3 in. from the face of wall, where visible to the public, to minimize staining. Where pedestrian or bicycle facilities are located along the front of walls, outlet drain pipes are to be placed below the facility and outlet into the adjacent gutter.

For box culvert wing walls and wing walls less than 30 ft. long and 16 ft. tall, use weep drains with 2 cu. ft. of porous backfill behind each drain. The requirements for outlet drain pipes are the same as for the continuous back drains.

## B. Abutments

Abutments support the ends of the bridge beams and provide for the transition from the bridge structure to the approach roadway pavement. All abutments retain the earth of the adjacent roadway and are subject to live load surcharge. Some types of abutments retain substantial amounts of fill. The abutment design must satisfy the requirements of a retaining wall. In addition, the overall stability and the foundation loads must be checked both with and without the dead and live loads from the superstructure. Provision shall be made for surcharge due to construction loads.

### 1. Types of Abutments

#### a. Gravity Abutments

As with gravity retaining walls, gravity abutments resist loads imposed on them by means of their mass. The resultant of forces must be within the middle third of any horizontal section through the abutment, both with and without the loads imposed by the superstructure.

#### b. Spill-Through Abutments

This type of abutment is designed with openings between the supporting legs to allow the embankment material to spill through and form a slope in front of the abutment. The abutment must be designed for the earth pressure on the backwall and cap and on the fill face of the supporting legs. The area of the legs shall be multiplied by a shape factor, usually 2.0, to allow for arching of the soil. If the embankment slope in front of the abutment is not subject to scour, passive earth pressure may be considered on the front face of the legs. The legs and cap shall be designed as a frame to support the loads imposed by the superstructure.

#### c. Stub Abutment on Piles

This type of abutment is similar to a spill-through abutment except that the piles are very flexible compared to the stiffness of the concrete stub. The piles shall be considered pinned at the footing and shall be designed for axial load only. Batter piles shall be provided to resist horizontal forces. The lateral resistance of the soil surrounding the piles will provide lateral stability and can resist an unbalanced shear which will depend on the nature of the soil.

#### d. Cantilever and Counterfort Abutments

Cantilever and counterfort abutments resist loads in a manner similar to their retaining wall counterparts.

#### e. Integral and Semi-Integral Abutments

Integral abutments eliminate the need for abutment roadway joints and hence provide a structure that will require minimal, if any, maintenance to the abutments and associated bearings. Integral abutments should be considered for new bridges when the project site conditions and geometry are suitable for these types of elements. Key considerations to be evaluated include soil type and profile, span alignment, length and skew, superstructure type and the presence of utilities on the bridge. In general, for integral abutment design to be considered, the soil type shall be a reasonably graded cohesionless soil with no defined rock line. Soil profiles suitable for driven pile foundations are also suitable for the installation of integral abutments. Integral abutments shall not be used when there is the possibility of pile downdrag forces.

Integral abutments shall only be considered for use on tangent superstructure alignment with a change in vertical grade less than 5% between abutments. Maximum span length for use with integral abutments is 200' and maximum skew (measured as the angle between the centerline of beam and a line normal to the centerline of bearing) is 30 degrees. Superstructure types that may be used with integral abutments include concrete slab supported by a redundant steel beam system or adjacent or spread prestressed concrete I-beams, box beams or slab beams. The use of timber superstructure components shall not be used with integral abutments. Normally, integral abutments are discouraged when the bridge carries utilities due to the required opening in the abutment stem to facilitate utility conduit expansion. This opening is a potential source of future deterioration and should be avoided, if possible.

Only cast-in-place concrete piles or steel H-piles shall be considered for use with integral abutments. If steel H-piles are selected, they shall be installed with the weak axis parallel to the centerline of bearing (i.e., driven to allow bending from thermal movements to be about the weak axis). Depending on the soil type and profile, consideration shall be given to pre-auguring a hole that extends a minimum of 10 feet below the bottom of abutment. The pre-augured hole shall be at least two times the pile diameter and filled with well-graded sand or a bentonite slurry mix. Piles shall extend to a sufficient depth to provide adequate structural stability (i.e., no "stiling" effect) and end fixity even when the adverse effects of scour are considered. A minimum of one pile per steel girder or spread prestressed concrete beam member shall be used.

Bearings shall be selected to resist the temporary loading imposed by the superstructure prior to encapsulating the ends of the beams and bearings with the deck closure pour. Minimalist bearings such as plain elastomeric pads should be considered.

Concrete approach slabs shall be used with all integral abutment designs and shall be structurally tied to the bridge deck slab and abutment stem via hinge reinforcement. If the end of the approach slab abuts rigid roadway approach pavement, provisions for expansion shall be implemented at this location. If the roadway approach pavement is flexible, the ends of the approach slabs may butt up against the section without expansion provisions being provided. The ends of approach slabs adjacent to flexible pavement shall be protected by steel angle armoring embedded in the slab with studs. Approach slabs shall be poured atop well graded aggregate and dual layers of polyethylene curing sheeting.

Semi-integral abutments also eliminate the need for abutment roadway joints, but since they are founded on a rigid foundation (e.g., spread footing, multiple rows of piles, etc.), expansion bearings will be required. Criteria for the use of semi-integral abutments are similar for that specified for integral abutments. Semi-integral abutments should be considered when the soil profile is not favorable (i.e., presence of rock, clayey soils, etc.) or if span lengths, geometry or alignment issues preclude the use of integral abutments.

## 2. Design Guidelines

### a. Lateral Earth Pressure

The lateral earth pressure shall be computed in the same manner as for a retaining wall.



b. Other Loads

In addition to lateral earth pressure, the abutment shall be designed to withstand the dead load of the abutment and superstructure, live load over any portion of the superstructure or approach fill, wind forces, longitudinal forces from the superstructure when the bearings are fixed and longitudinal forces due to friction or shear resistance of the bearings when the bearings are not fixed. The design shall be investigated for all combinations of these forces which may produce the most severe loading case.

c. Drainage

It is not necessary to provide drainage behind the stems of perched abutments when they are placed atop granular fill.

### C. Piers

1. Types of Piers

a. Rigid Frame Piers

Rigid frame piers consist of a continuous pier cap, columns and a continuous footing or independent footings. Rigid frame piers are generally used on bridges spanning highways and railroads.

b. Single Column Piers

Single column piers, or hammer head piers, consist of a pier cap supported by a single column. Single column piers are generally used for bridges spanning rivers or streams or where they are necessitated by space requirements.

c. Solid Stem Piers

The cap and column of a solid stem pier is a single unit supported by a continuous footing. They are used for short or narrow piers.

d. Pile Bents

Pile bent type piers consist of a single or double row of piles driven to act as both foundation and substructure elements. Superstructure loads are distributed to the piles via a rigid structural pile cap. Pile types normally considered in a pile bent type pier include timber, steel H-pile and cast-in-place concrete. A structural cap, normally constructed of reinforced concrete, encases the top portion of the piles to distribute superstructure loads. Pile bent piers shall be designed to account for the adverse effects of scour as it may create a longer unbraced pile length. Pile bents shall be checked against the ultimate scour condition. Both structural stability and pile stresses should be investigated.

Pile bent piers are normally utilized for stream crossings to minimize the impacts to the waterway during and after construction as well as minimize the reduction in the available hydraulic opening. Appropriate scour countermeasures shall be incorporated into the detailing of this pier type as required by the existing or proposed conditions.

2. Design Guidelines

a. Loads

Piers shall be designed to withstand the dead and live loads super-imposed thereon; wind pressures acting on the pier, the superstructure and on the moving live loads; shrinkage and temperature forces; forces due to stream current; and longitudinal traffic traction forces. These various forces shall be divided into components that are normal to and parallel to the centerline of the pier.

b. Application of Loads

Longitudinal forces are transferred to the substructure mainly through the fixed bearings acting at the hinge of the bearing. However, some longitudinal force will be transferred through the expansion bearings by virtue of friction. The maximum longitudinal force, due to superimposed loads or temperature effect, which is transferred to the pier at an expansion bearing, is equal to the bearing friction.

Transverse force may also be assumed to act at the hinge of the bearing. The total transverse force on the superstructure will be transferred to the piers and abutments in proportion to the length of the adjacent spans.

c. Columns

Rigid frame column spacing shall be in the range of from 12 feet to 20 feet. The spacing shall be set so that positive and negative movements in the pier cap are approximately equal. Circular pier columns whose diameter is 5'-0" or less shall be designed using spiral reinforcing.

## D. Foundations

1. Depth

Footings of all piers in the floodplain shall be founded on rock or on piles driven to rock, except as approved by the Chief of the Bureau of Engineering.

All other footings in the floodplains, including those for abutments, wing walls, and culverts shall be founded below the estimated depths of scour, or 3' below the thalweg, whichever is lower.

Footings outside the floodplain shall be founded on a suitable uniform foundation below the frost line and not less than 3'-0" below finish grade. Refer to the AASHTO LRFD Bridge Design Specifications (Ref. 1) for footings on slopes.

Footings on rock shall be keyed into the bedrock a depth of 12 inches when they are designed to transfer lateral forces. When a bedrock foundation is required for scour protection or design bearing pressure, footings shall be carried into bedrock a minimum of six inches. Spread footings on soil shall have the lower 1' in depth poured against undisturbed earth.

Plan sheets on which footings are shown shall include a note giving the allowable soil pressure or pile loads.

2. Loads

Footings shall be designed to transmit to underlying stratum all forces transmitted to and acting on the substructure component.

3. Pile Foundations

Available pile types that may be considered for use include timber, cast-in-place concrete, steel H-pile, and steel pipe pile. Each pile shall be evaluated for the project site conditions based on the available soil information, drivability, loading and structure location.

4. Drilled Shafts

Design of concrete drilled shaft foundations shall be done in accordance with AASHTO "LRFD Bridge Design Specifications" (Ref. 1) and utilizing LPILE by Ensoft, Inc. or another industry acceptable drilled shaft design program.

5. Design Guidelines

a. Location of Resultant Loads on Spread Footings

Footings founded on materials other than bedrock shall be proportioned so that the resultant intersects the bottom of the footing within the middle third. The resultant force on footings founded in bedrock may be outside of the middle third provided that the maximum allowable bearing pressure is not exceeded.

## b. Pile Foundations

Pile foundations shall be so proportioned that no pile receives more than the maximum allowable pile load and no pile is subjected to uplift under any combination of design loads. All pile foundations shall have batter piles to resist horizontal forces transmitted to the foundation and to increase the rigidity of the entire structure. Plumb piles may be assumed to resist 2 kips of lateral load per pile.

Resistance factors used to determine the nominal pile bearing resistance shall be selected based on the method used for determining the pile driving criteria in accordance with AASHTO LRFD Bridge Design Specifications.

## E. Substructure Protection

The selection and design of substructure protection to resist the effects of scour shall be in accordance with MDOT SHA guidelines and FHWA circulars and memorandums associated with scour countermeasure design. FHWA Hydraulic Engineering Circular 23 (HEC-23) (Ref. 18) shall be used in the design of countermeasures at piers and abutments.

Class II riprap is the preferred material for scour countermeasures. The  $D_{50}$  of the riprap shall be confirmed in accordance with HEC-23. Velocities used in the design of countermeasures shall be based upon the 100-year or incipient overtopping storm event, whichever yields a higher velocity, and shall be derived by using the hydraulic modeling techniques described in the MDOT SHA OOS "Manual for Hydrologic and Hydraulic Design" (Ref. 12). Configuration of the riprap blankets, including depth, distance from abutments/piers, toe dimensions, etc., shall be in accordance with MDOT SHA memorandum "Scour Countermeasures at Bridges" (November 25, 1992).

## F. Slope and Bank Protection

Slope and bank protection (revetments) for roadway approach embankments, retaining walls and stream channel banks shall be selected and designed in accordance with FHWA Hydraulic Engineering Circular 23 (HEC-23) (Ref. 18). Class II riprap is the preferred material for revetments.

Where applicable, revetments shall be designed to accommodate wave interaction as described in HEC-23. For the purpose of determining the total height of the revetment, the engineer should assume that the maximum wave height occurs coincidentally with the maximum water surface elevation generated by the design storm.

## 3.5 Bridge Superstructure

The bridge superstructure includes the slab, beams or girders and bearings. The function of the superstructure is to distribute and transmit loads to the substructure. Bridge superstructure shall be designed in accordance with AASHTO Specifications (Ref. 1).

### A. Slab on Beams and Girders

#### 1. Concrete

All superstructure concrete including parapets, abutment backwalls and parapet portion of wingwalls but excluding concrete overlay shall be air entrained concrete with a minimum 28-day compressive strength of 4500 psi. Slab concrete shall be low slump concrete.

#### 2. Wearing Surface

Concrete slabs shall have an extra 1/2-inch concrete which will serve as a wearing surface. This wearing surface shall be considered sacrificial and shall not be included when determining member strength.

#### 3. Reinforcing

Epoxy coated reinforcing bars shall be used for the entire superstructure, including top and bottom mats of slabs, abutment backwalls and parapet portion of wingwalls.

#### 4. Forms

Concrete slabs shall be poured on stay-in-place metal forms.

#### 5. Concrete Cover

Slabs shall have 2 1/2 inches of cover over the top reinforcing mat (which includes a 1/2-inch concrete wearing surface) or 1 inch of cover between the bottom reinforcing mat and the stay-in-place forms. Parapets and backwalls shall have 2 inches of cover.

### 6. Slab Thickness

Slabs shall be designed to carry the dead and live load loading in accordance with the AASHTO Specifications (Ref. 1). The minimum slab thickness including the concrete overlay shall be 7-1/2 inches.

### 7. Deck Pour Sequence

Construction plans shall include a suggested pouring sequence including the order and limits of each pour. For conventional superstructures (i.e., non-integral or non-jointless), positive moment regions of the superstructure shall be poured first followed by the pours in the negative moment region(s). For integral abutment bridges, the pouring sequence shall be configured to minimize dead load rotation at the abutment to prevent unwanted transverse deck cracking.

In developing the pour sequence, consideration shall be given to accounting for the temporary stresses on the in-place portions of the structure that may not have been considered such as lateral flange buckling of the longitudinal girders supporting the wet concrete. Individual concrete pours shall not exceed 100 cubic yards per day without written authorization of the Chief of the Bureau of Engineering.

### B. Beams and Girders

#### 1. Composite and Non-Composite Design

In superstructures consisting of concrete slabs supported on prestressed concrete beams or steel beams or girders, composite designs shall be used for simple spans exceeding 35 feet, and generally for continuous spans exceeding 50 feet. Because of the effect of span ratios, no specific limits for composite design can be established for continuous construction.

Continuous steel beam or girder spans shall be designed as composite for positive movement regions only; however, shear connectors shall be provided at maximum allowable spacing through the negative movement regions even though composite action is not considered.

## 2. Camber

### a. Spans Less than 50 Feet

Steel beams with a span of less than 50 feet shall not be cambered for dead load deflection or vertical curve corrections. If the beams are not rolled exactly true, they shall be fabricated and erected with their natural camber up.

### b. Spans 50 Feet or More

Steel beams and girders with spans of 50 feet or more shall be cambered to compensate for dead load deflection and vertical curve correction. Camber tolerance shall be zero (0) inches under to one-half (1/2) inch over.

## 3. Bearing Stiffeners

Stiffeners shall be placed at all bearings. The stiffeners shall be designed to carry the total reaction acting as a column.

## C. Steel Beams and Girders

Steel plate girders shall be designed, where economically feasible, to eliminate transverse and longitudinal web stiffeners. The use of AASHTO M270 Grade 50W steel must be approved on a case by case basis by the Chief of the Bureau of Engineering.

## D. Prestressed Concrete Beams

In lieu of steel beams or girders, precast prestressed concrete beams may be used for simple spans. The length and weight of any prestressed concrete member shall not exceed the State of Maryland limitations for highway shipment without permits.

## E. Bridge Drainage

Scuppers on bridges shall be avoided if possible. On closed systems inlets shall be placed immediately off the bridge at the upgrade end of the bridge to prevent accumulated gutter flow from entering the structure. On open section roadways inlets shall be placed immediately off the bridge at the downgrade end to control water accumulated on the bridge. On closed section roadways, inlets shall be placed downgrade from the bridge as required by the gutter flow design.

Scuppers shall be placed on the bridge only if the ponding encroachment exceeds the limit permitted by the Howard County Storm Drain Design Manual, (Ref. 7). Where required, scuppers shall be MDOT SHA standard scuppers. Scuppers shall be a minimum of 10' from any substructure unit. Downspouts shall extend 8" below adjacent stringers and shall outlet into streams, slope protection or splash blocks.

## F. Expansion Joints

Watertight roadway expansion joints shall be provided at all abutments and at all piers supporting simple spans. These joints shall provide for the total thermal movement for a temperature range of 0 F to 120 F.

Abutments integral with the superstructure should be considered where appropriate in lieu of expansion joints. Where feasible, joints shall be eliminated at intermediate pier locations via use of continuous spans, link slabs, or simple spans made continuous. If joints are required, they shall be selected to provide minimal irregularities and/or gaps to facilitate safe operation of motorcyclists and bicyclists.

## G. Bearings

The selection of bearings shall consider length of span contributing to expansion, superstructure material type, applied loading, bridge skew and degree of curvature (if applicable). Consideration should be given to selecting bearings that require minimal maintenance including plain and steel laminated elastomeric pad bearings with or without polytetrafluoroethylene (PTFE) – stainless steel sliding surfaces. Bronze sliding bearings shall be considered for steel structures. Refer to the MDOT SHA "Structural Details Manual" (Ref. 11) for suggested bronze sliding bearings. The use of steel rocker bearings is prohibited.

Elastomeric bearings are generally used to support precast prestressed concrete slabs or beams. Plain pads are preferred unless structure rotation and thermal translation require steel laminated bearings. Elastomeric bearing shall be adequately attached to the bearing seat via an appropriate epoxy bonding compound. Provisions shall also be considered to prevent the elastomeric pads from “walking” by using restrainer bars, plates or angles or by inserting an anchor dowel through the ends of the precast prestressed concrete member and embedded into the beam seat.

## H. Drainage Troughs

Drainage troughs shall be investigated for use on new structures or rehabilitated structures where open joints (e.g., finger joints) are located in the bridge deck. Troughs shall also be considered as a way of providing a redundant system to protect specific bridge elements if the roadway joints begin leaking. Fiberglass drainage troughs shall be used underneath all open joint systems and shall be installed using a cross slope no less than 1” per foot. Adequately sized catch basins shall be incorporated into the system to collect all drainage water and efficiently disperse it away from the structure by means of downspout piping. Suitable caulking material shall be used along the interface between the structure and the trough to prevent water seepage.

Neoprene drainage trough material may be used in other locales assuming that the anticipated drainage flow will not exceed the capacity of the trough. Troughs placed underneath closed joint systems shall be installed at a cross slope of no less than ¼” per foot. Stiffening bars shall be incorporated into the system to keep the neoprene material flush up against the structure to prevent water seepage.

Stainless steel hardware shall be used to affix the drainage trough to the structure. Downspout piping shall be incorporated into the drainage trough systems when necessary to convey drainage away from the structure. PVC conduit shall be used for the piping material and it shall be adequate attached/braced against the structure to maintain the integrity of the system. Stainless steel hardware shall also be used to brace the downspout piping. Discharge from any downspout piping shall be directed away from structure foundations and/or adjacent roadway surfaces. Refer to the MDOT SHA Structural Details Manual (Ref. 11) for suggested drainage trough details.

## I. Elevations

Bridge deck elevations shall be computed and indicated on the plans at each girder centerline, PG/L of the roadway, at any roadway break lines and along the gutter flow lines. Elevations shall be provided in accordance with MDOT SHA Structural Guidelines and Procedure Memorandums (Ref. 10).

## J. Sidewalks

Any surface features in the sidewalk shall be smooth, slip-resistant, and level with the sidewalk to maintain ADA compliance.

## 3.6 Shared Use Path Bridges

### A. General

Shared use path bridges carry users such as bicyclists, pedestrians, equestrian riders and light maintenance vehicles.

#### 1. Design Specifications

##### a. AASHTO

The design of shared use path bridges shall be in accordance with the “LRFD Bridge Design Specifications” (AASHTO, Ref. 1), including subsequent interim specifications, except as modified by the “LRFD Guide Specifications for the Design of Pedestrian Bridges” of the Association of State Highway and Transportation Officials (AASHTO, Ref. 21), including subsequent interim specifications.

Shared use path bridges shall also be in accordance with the “Guide for the Development of Bicycle Facilities” of the Association of State Highway and Transportation Officials (AASHTO, Ref. 23), including subsequent interim specifications.

##### b. ADA

All designs shall meet or exceed Americans with Disabilities Act (ADA) guidelines to the extent that it is not structurally impractical to do so.

### B. Loading

Live load shall be in accordance with AASHTO (Ref. 21). Whenever vehicle access is not prevented by permanent physical methods, shared use path bridges shall be designed for H5 vehicle live load, or a different vehicle depending on the needs of the owner or jurisdiction.

### C. Clearances

#### 1. Horizontal Clearance

In accordance with the AASHTO “Guide for the Development of Bicycle Facilities” (Ref. 23), a shared use path bridge shall have a 14’ preferred clear width (12’ minimum clear width) unless written authorization is provided by the Chief of the Bureau of Engineering.

#### 2. Vertical Clearance

The minimum vertical clearance from the surface of path to an overhead obstruction shall be 10 feet. Greater vertical clearance should be considered where maintenance vehicles or emergency vehicles may use the path.

Figure 3-2. Horizontal and Vertical Clearances for Shared Use Path Bridges.

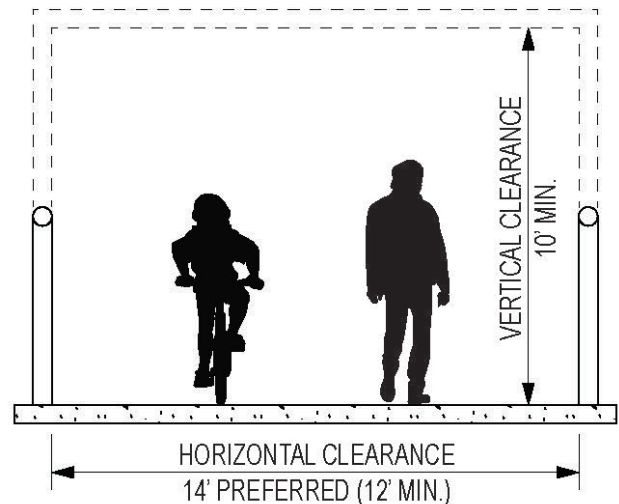



**D. Profile and Grade**

The deck of the bridge should maintain the cross slope of the approach path. Where pedestrians are present, this cross slope should not exceed 2% to meet accessibility guidelines. Refer to Chapter 2, and the provisions given by AASHTO (Ref. 23) for profile and grade requirements.

**E. Railings and Fencing**

All railings on bridges and approaches, including transitions, shall meet or exceed MDOT SHA and AASHTO specifications, including crash testing requirements. Pedestrian and bicycle railings shall conform to the "Bridge Railing Manual" by MDOT SHA (Ref. 25) and the AASHTO "Guide for the Development of Bicycle Facilities" (Ref. 23). unless written authorization is provided by the Chief of the Bureau of Engineering. If a railing type is selected that is not included in those references it shall meet all geometric criteria of the AASHTO specifications. Rub rails shall be considered as specified in the AASHTO specifications (Ref. 23) where a bicyclist's handlebar may come into contact with a railing or barrier. Railings should not impede stormwater runoff. Refer to Section 3.2.J.3 for additional information on barriers.

If the shared use path bridge crosses a high volume or high-speed roadway, or objects are likely to be thrown from the structure, fencing shall be considered. Fencing shall meet MDOT SHA "Structural Details Manual" (Ref. 11). Fencing installed on structures crossing over railroads shall meet the minimum requirements of the respective railroad.

**F. Lighting**

Refer to the "Guide for the Development of Bicycle Facilities" (AASHTO, Ref 23) for lighting requirements.

When lighting for shared use path bridges is provided on poles, it should be independent of the bridge structure where possible.

**G. Aesthetics/Structure Type**

The Aesthetic Bridges - Users Guide (Ref. 26) provides recommendations for design suggestions and considerations.

**H. Hydraulics**

Refer to Appendix D in Chapter 10 of the MDOT SHA OOS "Manual for Hydrologic and Hydraulic Design" (Ref. 12).

### 3.7 Shared Use Path Underpasses

#### A. General

Shared use path underpasses carry users such as bicyclists, pedestrians, equestrian riders, and maintenance vehicles. Shared use path underpasses include tunnels and openings under bridge structures.

##### 1. AASHTO

The design of shared use path underpasses shall be in accordance with the “LRFD Bridge Design Specifications” (AASHTO, Ref. 1), including subsequent interim specifications.

Shared use path underpasses shall also be in accordance with the “Guide for the Development of Bicycle Facilities” of the Association of State Highway and Transportation Officials (AASHTO, Ref. 23), including subsequent interim specifications, the “Guide for the Planning, Design and Operation of Pedestrian Facilities” (AASHTO, Ref. 27), including subsequent interim specifications, and the “Roadway Lighting Design Guide” (AASHTO, Ref. 28), including subsequent interim specifications.

##### 2. ADA

All designs shall meet or exceed Americans with Disabilities Act (ADA) guidelines to the extent that it is not structurally impractical to do so.

#### B. Clearances

##### 1. Horizontal Clearance

In accordance with the AASHTO “Guide for the Planning, Design and Operation of Pedestrian Facilities” (Ref. 28), a shared use path underpass shall have a 14’ preferred clear width (12’ minimum clear width), unless written authorization is provided by the Chief of the Bureau of Engineering. Wider widths should be considered for lengths over 60 feet. Consideration shall be given for longer underpasses to enhance visibility, security, and safety via wider openings or flared ends.

##### 2. Vertical Clearance

The minimum vertical clearance from the surface of the path to an overhead obstruction shall be 10 feet, 12 feet if equestrian accommodation is required. Greater vertical clearance should be considered where maintenance vehicles or emergency vehicles may use the path, or for longer underpass lengths to maintain openness and security for pedestrians.

Figure 3-3. Horizontal and Vertical Clearances for Shared Use Path Underpasses.

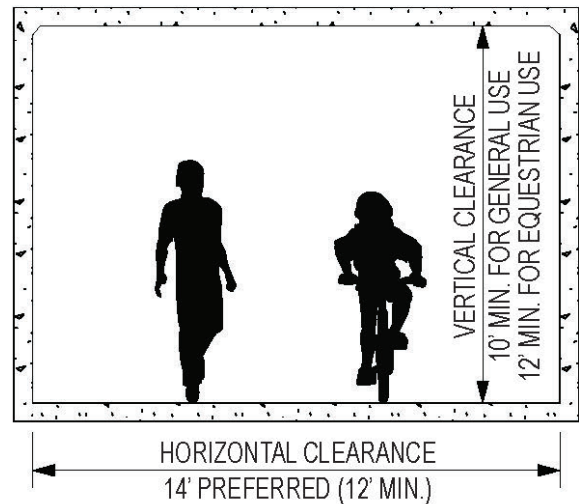

#### C. Profile and Grade

The surface of the shared use path should maintain the cross slope of the approach path. Where pedestrians are present, this cross slope should not exceed 2% to meet accessibility guidelines. Approaches and grades should be evaluated to provide the maximum possible field of vision towards the underpass. Refer to Chapter 2 and the provisions given by AASHTO (Ref. 23) for profile and grade requirements.

#### D. Fencing

Refer to Section 3.2.J.3 for fencing requirements.

## **E. Lighting**

All shared use path underpasses where pedestrians, bicyclists, equestrians, or maintenance vehicles may be present require lighting. Luminaires shall be mounted to the underpass walls. Vandal resistant lighting should be installed and maintained. Refer to the “Guide for the Development of Bicycle Facilities” (AASHTO, Ref. 23) and the “Roadway Lighting Design Guide” (AASHTO, Ref. 28) for lighting requirements.

## **F. Aesthetics**

The Aesthetic Bridges - Users Guide (Ref. 26) provides recommendations for design suggestions and considerations.

## **G. Drainage**

Drainage shall be carefully considered for shared use pathway underpasses to prevent flooding. Underpasses shall be designed to avoid sumps in vertical alignments and configurations where non-free-draining systems (e.g. pump stations) are required to prevent flooding. Underpasses shall not be located in areas of known flooding or floodplains where pedestrian egress may be restricted during storm events.

## 3.8 Box Culverts

### A. Analysis

Box culverts shall be analyzed as closed rigid frames. The dead and superimposed earth loads, the lateral earth pressures and the live and impact loads are to be analyzed separately. The results of these separate loading conditions shall be assembled in various combinations to give maximum moments and shears at the critical points; i.e., the corners, and the positive moment areas. Appropriate live load positions shall be used to produce maximum positive or negative moments. A maximum of one-half of the moment caused by lateral earth pressure, including any live load surcharge, may be used to reduce the positive moment in the top and bottom slabs. The weight of the bottom slab of a box culvert will be resisted by an equal and opposite soil pressure and the weight of the slab will cause no bending in the structure. The structure should therefore be analyzed for a net soil reaction, excluding the reaction to the weight of the bottom slab.

### B. Design Guidelines

#### 1. Minimum Thickness

The thickness of walls and slabs of a box culvert shall be not less than 8 inches for members with single reinforcing and not less than 12 inches for members with reinforcing in both faces.

#### 2. Minimum Reinforcing Cover

The minimum cover shall be as follows:

- Bottom of bottom slab - 3 inches
- Top slab used as riding surface - 2 1/2 inches (including 1/2-inch concrete wearing surface)
- All other faces — 2 inches

#### a. Epoxy Coated Reinforcing

When the distance from the riding surface to the top slab is less than 2', all reinforcing in, or extending in, the top mat of reinforcing steel for the entire length of the culvert shall be epoxy coated.

#### 3. Wearing Surface

If the top slab is to be used as a roadway riding surface, it shall have a 1/2" integral concrete wearing surface. This wearing surface shall be considered sacrificial and shall not be included when determining member strength. When the top slab is not the riding surface, the earth cover provided shall be no less than 9 inches (in addition to paving) at the minimum point.

#### 4. Contraction and Expansion Joints

Contraction joints shall be provided at a spacing of approximately thirty (30) feet. Expansion joints shall be provided at approximately ninety (90) foot intervals. Reinforcement shall be stopped two (2) inches clear of joints.

#### 5. Headwalls

Headwalls shall be provided at the exposed ends of box culverts, to retain the earth cover and to act as edge distribution beams on skewed alignments. The headwall shall be constant height.

#### 6. Cut-Off Walls

In order to provide for effects of scour, cut-off walls, a minimum of three (3) feet deep, shall be provided at the exposed ends of the culverts. Wing wall footings shall be set at the elevations of the bottom of the cut-off walls and securely tied to them with reinforcement.

#### 7. Provisions for Future Extension

If the culvert is to be placed under a roadway which could be widened in the foreseeable future, provisions shall be made for extension of the culvert by placement of appropriate joint keys on the exposed inlet and outlet faces.

### C. Bottomless Box Culverts (Rigid Frames)

Bottomless culverts may be considered when it is desirable from a permitting standpoint to put in a culvert with a natural channel and the span length is such that using a structural plate pipe arch is uneconomical. Since the foundation loads on a bottomless culvert are relatively higher than a four-sided box, the existing subsurface information must be closely analyzed to determine if the culvert can be supported by spread footings. If the resultant bearing pressure is too high when compared to the allowable, or the adverse effects of settlement is a possibility, placing the structure on piles should be considered. Regardless of the foundation system, the bottom of footing for any rigid frame shall be placed a minimum of 3 feet below proposed groundline.

Bottomless culverts shall be analyzed for scour in accordance with current MDOT SHA guidelines. The Designer should consult with the MDOT SHA Office of Structures for guidance on the selection of bottomless culverts and the preferred scour analysis and countermeasure design procedures.

## 3.9 Pipe Culverts

The hydraulic design and analysis of roadway cross culverts should be performed in accordance with the guidelines contained in the Howard County Storm Drainage Design Manual, FHWA HDS-5, MDOT SHA OOS “Manual for Hydrologic and Hydraulic Design” (Ref. 12) and applicable MDE and USACE regulations. This section deals specifically with larger culvert crossings of waterways with base flow.

### A. Geometry

Pipe culverts shall be designed to carry the full ultimate roadway section including safety grading, guardrail backing, etc.

The layout of any pipe culvert shall be configured primarily to preserve existing drainage patterns and watercourses, while integrating the overall geometry of the roadway embankment. Significant guidance is available in Chapter 13 of the MDOT SHA OOS “Manual for Hydrologic and Hydraulic Design” (Ref. 12) and in HDS-5 regarding the optimal configuration of the culvert to accommodate different channel types.

When culverts are used singularly at crossings, the pipe invert shall be set 1' below the planned bottom of stream bed. When multiple pipe culverts are used in a single crossing, one pipe shall be considered the low flow cell and have its invert set 1' below the planned bottom of stream bed; the remaining pipes shall have their inverts set 1' above the low flow invert. Natural siltation will fill the bottom of the pipe to the planned stream bed level.

For pipe culvert crossings of Non-Tidal Wetlands and Waterways, including Water of the U.S., the Designer shall be thoroughly familiar with the regulations of COMAR Section 26.17.04.06, Bridges and Culverts. The engineer should be aware that, for any such crossing, culvert lengths are typically limited to 150 feet by COMAR 26.17.04.06.B.3. In addition, this section of COMAR also requires that culverts conveying such waters have inverts buried by at least 1 foot. For any such crossing, the Designer shall coordinate with regulating agencies at the concept stage in order to confirm the basic type, size and location of the culvert prior to proceeding with final design.

### B. End Treatment

Steel pipe culverts derive their strength from the interaction of the soil with the pipe. At pipe ends, this interaction no longer applies and the end treatment must be detailed to stiffen the pipe as well as to protect against hydraulic and erosion forces.

#### 1. Headwalls

For culverts with greater than 5' of fill measured at the start of the fill slope, headwalls shall generally be the minimum height possible. There shall be 9" of cover from the top of the pipe to the ground line at the back face of headwall and there shall be 9" freeboard from the ground line to the top of headwall at the back face of wall. Regardless of whether the headwall is perpendicular to the culvert or parallel to the roadway, the top of the headwall shall be level.

For culverts with less than 5' of fill measured at the start of the fill slope, the headwall shall generally be placed so that the barrier on the headwall lines up with the traffic barrier on the approach roadway.

The front and back faces of the headwall shall extend a minimum of 1' horizontally beyond the pipe prior to the start of the wingwall. The portion of the headwall over the pipe shall be designed as a horizontal beam carrying the horizontal loads to either side of the pipe. The portions of the headwall immediately beside the pipe shall be designed as a cantilever, fixed at the footing, and shall carry the horizontal loads from the area over the pipe as well as loads placed on it directly. The pipe shall be attached to the headwall by J bolts at 18" c/c around the perimeter. No load from the headwall shall be assumed to be carried by the pipe.

Details of the headwall shall include a plan view drawn to a scale of  $3/8" = 1'-0"$  or larger depicting placement of the headwall reinforcing.

The bottom of the headwall and wing wall footings shall be a minimum of 3' below the low flow pipe invert elevation. A toe wall may be placed below this if required but a bottom of footing less than 3' below the low flow pipe invert in conjunction with a toe wall shall not be acceptable. Shear keys and/or passive pressure to increase the sliding resistance shall not be considered.

Headwalls on large pipe culverts should generally be oriented parallel with the roadway embankment. For smaller culverts and headwalls not visible from the roadway, headwalls may be oriented perpendicular to the centerline of the pipe.

Headwalls for large culverts should have the edges beveled at a minimum angle of 45 degrees around the entire pipe circumference. The use of flared wingwalls may be required to reduce erosion at culvert inlets and outlets. In general, upstream wingwalls should be flared at 1:1 from parallel with the direction of flow. A 4:1 flare is recommended for downstream wingwalls (4 in the direction of flow to 1 perpendicular to the direction of flow).

Culvert headwalls that are to be used for earth retaining in excess of standard dimensions (i.e. greater than 6 inches above the top of the pipe) will require special design. The concept of using a standard headwall in conjunction with a smaller diameter pipe, such as a 36-inch pipe used with a standard headwall for a 48-inch pipe, will not be acceptable. The Designer shall have the responsibility of designing such retaining-type headwalls in accordance with the AASHTO "LRFD Bridge Design Specifications" (Ref. 1).

## 2. Other End Treatments

End treatments other than head walls are generally allowed if they conform to the pipe manufacturer's recommendations. Step beveled ends are preferred over fully beveled ends for their added stiffness however both require concrete collars/slope protection with J bolts at 18" c/c and toewalls extending 3' below the low flow pipe invert. Particular care must be taken with beveled ends for pipe arches due to their stiffness requirements.

It is structurally preferred for pipe ends to be on an axis perpendicular to the pipe centerline. For pipes not perpendicular to the centerline of the roadway, this may require warping the fill slopes. This structurally preferred solution may entail excessive cost for large culverts, may present aesthetic concerns for culverts with limited fill or may be impractical due to the right of way limitations. Each culvert site shall be examined in terms of end treatment.

Exposed square ends are not permitted except as temporary structures for aesthetic considerations.

Reinforced concrete or corrugated metal end sections are acceptable for use on single pipe culverts up to 36-inches in diameter, depending upon the application. When riprap is specified in conjunction with an end section, the riprap shall extend to the intersection of the end section and the pipe. End sections shall not be substituted for headwalls if the skew of the pipe is greater than 60 degrees to normal or if the pipe carries base flow.

Large-diameter culverts with extremely high outlet velocities (typically in excess of 20 feet per second) may require the design of specialty energy dissipaters. These dissipaters are typically cast-in-place or precast concrete. The methodologies presented in FHWA Hydraulic Engineering Circular 14 (HEC 14) (Ref. 19) shall be used in the design of any such dissipaters. The structural design of these units shall be in accordance with the AASHTO "LRFD Bridge Design Specifications" (Ref. 1).

## 3. Stream Protection

Where required due to high outlet velocities or stream instability, channel protection shall be designed in accordance with the methodologies of FHWA Hydraulic Engineering Circular HEC 20 (Ref. 20) and the guidance presented in Chapter 10 of the MDOT SHA OOS "Manual for Hydrologic and Hydraulic Design" (Ref. 12). Severe stream instability at culvert outlets should be assessed by qualified engineers experienced with fluvial geomorphology and Rosgen stream restoration techniques.



### C. Foundation Requirements

Large culverts in excess of 48 inches in diameter shall be bedded in a concrete cradle which will support the pipe for at least 10 percent of its overall height.

Multiple-cell pipe culverts shall be spaced so that adjacent outside surfaces are as follows:

- Diameter less than 48 inches: Not less than 2 feet apart.
- Diameter greater than 48 inches: One-half the diameter or 3 feet apart, whichever is less.

This section applies to steel pipe culverts with spans greater than 8' measured perpendicular to the pipe.

A normal foundation report shall be required, refer to Section 3.2.M.

## 3.10 Utilities on Bridges

### A. Telephone Lines & Cable

Galvanized steel conduits will only be allowed to be placed in the sidewalk slab of the bridge.

### B. All Other Utilities

No utilities other than telephone conduits will be permitted to be placed on a bridge. No conduit shall be placed closer than ten (10") inches from the face of the curb and three (3") inches from the inside face of the parapet or twelve (12") inches from the edge of the slab if no parapet is provided.

## 3.11 Rehabilitation of Existing Structures

### A. Introduction

This section addresses the rehabilitation of existing structures as part of an overall program to repair various Public Works structures. The goal of rehabilitation is to maintain the safety and structural integrity of the structure as well as extend its useful service life. The focus of any rehabilitation program is to effect repairs to key or critical structure elements in a timely manner to eliminate the need to replace the entire unit.

Structures designed per AASHTO LRFD (Ref. 1) shall be evaluated using AASHTO LRFD (Ref. 1). Structures designed by Load Factor Design (L.F.D.) or Allowable Stress Design (A.S.D) methods may be evaluated with either the AASHTO Standard Specifications (Ref. 24) or AASHTO LRFD (Ref. 1). It is appropriate and acceptable to analyze older structures with the AASHTO Standard Specifications (Ref. 24). However, in some cases, an LRFD analysis may yield more favorable results due to more refined methods of live load distribution or structural capacity. The intent of this provision is to not preclude the use of LRFD in these situations. A structure found to meet the minimum performance criteria when checked with either code should be considered acceptable. When projects in this category require the design of a new element or retrofit, it is preferred to use AASHTO LRFD (Ref. 1), when practical.

The design of temporary works (e.g., falsework) shall be performed in accordance with applicable sections of the latest edition of the AASHTO "Guide Design Specifications for Bridge Temporary Works" (Ref. 16) and the AASHTO "Construction Handbook for Bridge Temporary Works" (Ref. 17).

Bridge widths, including travel lanes, shoulders, and pedestrian and bicycle facilities, shall conform to Section 3.2.1 to the extent practical. If the scope of the project does not allow for the full width of those facilities, consideration should be given to retrofits that provide additional space for pedestrian and bicycle travel. In constrained conditions on bridges with inadequate pedestrian and bicycle facilities, priority should be given to narrowing or reconfiguring motor vehicle lanes or medians to provide additional space for pedestrians and bicyclists. Priority should also be given to adding some separation (if feasible) between the travel lanes and the adjacent pedestrian/bicycle facility, such as a curb, a concrete barrier, or flexible delineators. Separation is a particular need on bridges with motor vehicle operating speeds over 35 mph that are more than 100 feet long.

Figure 3-4. Potential Separation Options on Bridges.

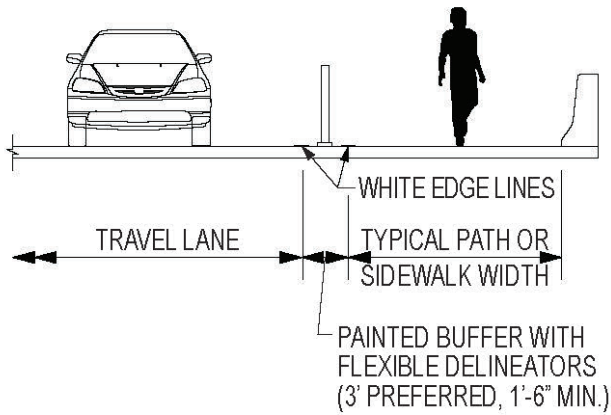

**FLEXIBLE DELINEATORS**  
Generally for speeds < 25 mph

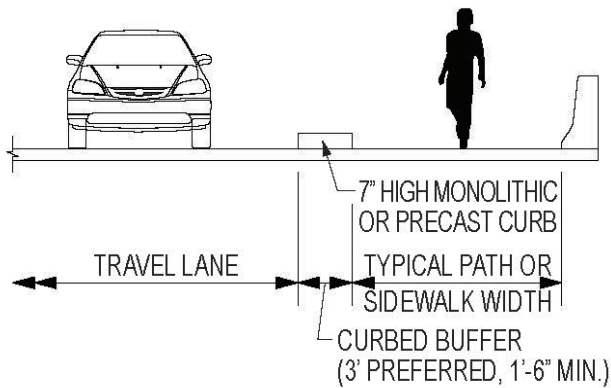

**CURB**  
Generally for speeds < 35 mph

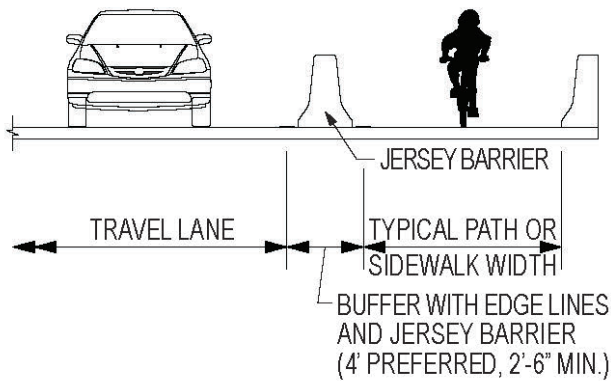

**JERSEY BARRIER**  
Generally for speeds > 35 mph

## B. Superstructure Repairs

Superstructure repairs include rehabilitating those bridge elements located above the abutment or pier beam bearing seat. The elements to be addressed include decks, roadway barriers and sidewalks, roadway joints (transverse and longitudinal), drainage devices (including scuppers, troughs and downspout pipes), approach slabs, structural framing systems and bearings.

### 1. Bridge Decks

In general, the rehabilitation of bridge decks will consist of maintenance repairs of the roadway surface (or soffit), removal of the top portion of the deck and placing a specialized concrete overlay or a complete deck replacement. The scope of rehabilitation should be based on the latest inspection information and all available testing data as appropriate. If inspection and testing information is unavailable, it is desirable to obtain this data through an in-depth inspection of the bridge deck and an adequate testing program. The in-depth inspection should focus on determining areas containing concrete defects that require repair including delaminations, spalling and cracking. All areas shall be thoroughly documented by defect type and location.

The in-depth inspection shall include visual and tactile inspection methods including hammer tapping, chain drag and other nondestructive tests to evaluate the deck condition. Based on this information, concrete cores should be taken to evaluate, at a minimum, the compressive strength and chloride ion content of the deck concrete. Cores shall be taken in areas containing observed deterioration as well as areas in relatively good condition (as a control). A minimum of two (2) cores shall be taken for any bridge including a minimum of one (1) per span for multi-span structures. Cores shall not be taken directly over any main longitudinal or transverse structural members. Pending the results of the in-depth inspection and testing, a rehabilitation scheme can be recommended to repair the deck in place, install an overlay or replace the deck.

An estimate of the remaining service life should be made accounting for the current age of the deck, its current strength as compared to the original design strength, chloride ion content, location and extent of any observed structural cracking and the location and extent of concrete deterioration. The remaining service life estimate should be considered in the final decision to rehabilitate or replace the deck.

Concrete deck repairs involve placing an adequate concrete patching material in an area that has been first properly cleaned and prepared. Any area to be repaired shall have all deteriorated and loose concrete removed, exposed reinforcing steel cleaned of all rust (and replaced if it has lost more than 20% of its original section), and the area air blast or water-jet blast cleaned. Concrete patch material shall be chosen based on factors including durability, suitability of the material for the repair location, curing time (as it relates to opening lanes back to traffic) and cost.

If it is determined that the deck has adequate overall strength and some remaining service life left, a specialized concrete overlay may be considered. A concrete overlay will help to protect the remaining portions of the deck as well as extend the remaining service life of the bridge deck. Generally, only 1" to 2" of the existing concrete deck surface is removed (where the potential for delaminations or a high concentration of chloride ions exist) and the surface prepared to receive the overlay material. As part of the surface preparation process, localized concrete repairs may be required to ensure that the rehabilitated deck is a sound and integral element. Material(s) used in the patching process discussed previously are suitable for this repair. The overlay material shall be a dense cementitious type material suitable for placing in relatively thin applications. Materials such as latex modified concrete, micro-silica concrete and very early high strength latex concrete should be considered depending on the application needs. The structural capacity of the deck should be verified if more than 2" of concrete is removed from the top surface.

If the selected rehabilitation alternative is for complete replacement of the concrete deck, several issues shall be evaluated, including, but not limited to, studying and developing stages of construction for maintenance of traffic, need to maintain pedestrian and/or bicycle traffic, maintenance of utilities, checking the existing framing system for the new deck weight including the consideration of the effects of composite action and differential camber in adjacent beams (as a result of staged construction) and the rehabilitation needs for the substructure and those superstructure elements to remain.

Other rehabilitation work associated with the bridge deck will be the repair or replacement of existing roadway joint systems. The failure of transverse (and longitudinal) roadway joints may lead to substructure deterioration, bearing failure and section loss at the ends of the main superstructure supporting members. Depending on the severity of the joint deterioration, only the replacement of the seal may be required. Field measurements of the joint opening should be taken along with the ambient temperature to ensure that the correctly sized seal is installed. If the condition of the joint system is such that replacement is required, the existing joint configuration should be confirmed in the field and checked against available plans. If plans are unavailable, field measurements and details of the existing joint system shall be recorded for subsequent use in preparing joint replacement plans. As part of any joint modification scheme, consideration should be given to installing drainage troughs in accordance with Section 3.5.H of this Design Manual. The replacement joint system chosen (armored compression or strip seal, asphaltic plug, silicone, elastomeric, etc.) shall take into consideration such factors as cost, serviceability, durability (i.e., resistance to truck traffic) and constructability. Where feasible, the elimination of transverse joints should be investigated to extend the service life of bearings, beam ends, and other bridge components historically affected by failing joints. An appropriate structural analysis of the existing structure should be completed to determine the applicability and suitability of installing link slabs at intermediate pier roadway joints and/or a conventional deck-over system at each abutment. The ability of existing bearings to accommodate link slabs and/or deck-over details shall also be confirmed and the replacement of

same evaluated to determine if their replacement is cost-effective in conjunction with the removal of transverse joints.

As part of a deck maintenance program, consideration should be given to eliminating bridge scuppers. If feasible, eliminating scuppers will minimize the deterioration of the deck from standing water/debris resulting from clogged scuppers. An analysis of the scupper(s) shall be performed and if the design spread for a ten-year storm event does not encroach more than 6 feet into the traveled way. Scuppers to be eliminated shall be filled with a lean concrete mix.

## 2. Barriers

Traffic barriers include railings and parapet systems. Barriers inadequately attached to the superstructure (as a result of deterioration, accident damage or substandard design) shall be rigidly connected to the deck and/or fascia beams to provide sufficient strength to resist vehicular impacts.

## 3. Girders/Beams/Trusses

These repairs encompass many different types of repairs and will include all work to rehabilitate girders, beams and trusses.

There are many types of repairs that may be performed on steel beams/girders. Rusted webs can be repaired by welding or bolting plates across the deteriorated areas. Deteriorated flanges may be repaired by welding or bolting cover plates across the deteriorated or damaged areas. Care must be taken when welding to ensure that allowable fatigue stresses are not exceeded and that weld quality can be obtained under field conditions.

For bridges with high volumes of truck traffic, repairs may involve the retrofitting of beams/girders at intermediate diaphragms or cross frame connections to prevent and/or mitigate problems at fatigue-sensitive connection details. Cracks in welds, as well as, cracks in the web and connection plates, have resulted from these fatigue-sensitive connection details. Retrofit details to consider include bolting angles or tees to the connection plates and flanges to prevent and/or mitigate out-of-plane bending or high-stress concentrations. In addition to this

retrofit, welds may be repaired via grinding, drilling crack ends and replacing any cracked connection plates. Each situation must be carefully studied to ensure that the retrofit detail can be properly constructed in the field and that it will be achieving its intended purpose of eliminating and/or reducing out-of-plane bending or high-stress concentrations.

Although most projects will involve the repair and/or replacement of select members, in some cases, it may be desired to upgrade the load-carrying capacity of a structure. This can be accomplished by several methods, including applying more advanced analysis methods, rating the structure using load and resistance factor design, replacing the deck with lightweight concrete or a different type of lightweight deck (e.g. exodermic, etc.), making multiple simple spans continuous over the piers, post tensioning, or adding shear studs to make non-composite beams composite. When adding studs for the development of composite action, the type of steel being stud welded must be carefully evaluated. Older steels (e.g., A7) are not as ductile as current steel and special care must be utilized when attaching any element via welding.

Trusses often need to be strengthened because of deterioration at the lower chord and connections. Strengthening can be accomplished by the addition of stressing cables or splicing of the chords themselves. Care must be taken in these repairs because of the lack of structural stability when a lower chord member is disconnected. On many trusses, the floorbeam/stringer framing system, including connections, may need rehabilitation and/or upgrading. Many of these repairs can be handled as stated above for steel beams/girders.

Timber beams deteriorating as a result of decaying wood or insect attack can be rehabilitated by replacing individual members or strengthening by thru-bolting galvanized steel channels to each side.

Rehabilitation of concrete tee-beam bridges typically involve beam repairs to address spalling, cracking and any exposed reinforcing steel that has lost cross sectional area. If the extent of deterioration does not compromise the ability of the member to safely carry load, cosmetic repairs using pneumatically applied

mortar may be utilized to halt further deterioration. If the extent of corrosion adversely affects the load carrying capacity of the member, and the bridge cannot be load restricted, external reinforcement such as carbon fiber reinforced polymer sheets can be bonded to the sides and bottom of the beam to upgrade the live load capacity.

Prestressed members with concrete spalling can be repaired after cleaning of the strands. Some preloading of the beam may be necessary to prevent future cracking of the concrete patch. If prestressing strands are damaged or severed to a point where the load-carrying capacity of the member is inadequate, the member can be repaired by providing external post-tensioning. This method can also be used to increase the strength of under-designed prestressed beams. In addition, the use of external reinforcement such as carbon fiber reinforced polymer sheets can be bonded to the sides and bottom of the beam to upgrade the live load capacity in shear and/or bending.

#### 4. Bearings

Deteriorated bearings may need to be cleaned and painted, reset or replaced with a similar or better functioning bearing device. To reset or replace bearings, the bearing load must be released through the use of hydraulic jacks and temporary jacking beams supported by the existing girders. Steel columns anchored to the face of the substructure may also support the jack(s). Or, if space allows, the jack(s) can be placed on the beam seat behind the end of a girder. The design plans shall clearly state the limits of the jacking system with respect to load, the amount of girder displacement that can be tolerated and whether traffic can be maintained on the bridge during the jacking operations. The existing structural components must also be checked to confirm their ability to withstand the jacking forces.

For bearings exhibiting extensive and advanced paint deterioration and base metal corrosion, complete cleaning and repainting may be necessary to restore full operational capacity to the bearings. In addition, these bearings may have to be jacked and temporarily supported to facilitate a more thorough cleaning. Reference

the following section for the cleaning and painting of steel bearings.

#### 5. Painting

The painting of steel superstructure elements (beams, girders, diaphragms, bearings, etc.) encompasses the cleaning and painting of all exposed surfaces as part of a maintenance or rehabilitation project. Depending on the condition of the paint system, either spot cleaning and painting or complete removal and replacement of the paint system may be required. However, if the paint system condition is relatively good, minor cleaning and overcoating may be a more economically viable alternative to full removal and coating. Spot cleaning shall extend a minimum of 10' from the beam ends on simple spans and 10' from the centerline of bearing on continuous spans. Steel bearings and associated end diaphragms should be included within these limits. Other areas of additional spot cleaning (e.g., exterior sides of fascia girders) shall be included as necessary.

The existing paint system should be evaluated for adhesion in accordance with ASTM D4541 as well the coating thickness and the compatibility of the existing coating with the new coating. Evaluation of the paint system shall be in accordance with the current edition of the "SSPC Painting Manual, Volume 2" (Ref. 13).

Prior to cleaning and painting, the existing paint system shall be evaluated for the presence of lead paint. If lead paint is present, contract specifications shall be prepared for proper and adequate lead paint removal and containment and worker protection (reference Volume 4 – Specifications for more information). 100 percent containment of blast by-products shall be contained. The design of the containment system shall be borne by the Contractor performing the work.

The new paint system(s) shall be in conformance with the Volume 4 Specifications assuming that it is compatible with the existing paint system.



## C. Substructure Repairs

Substructure repairs include rehabilitating those bridge elements located at or below the abutment or pier beam bearing seat. The elements to be addressed include beam seats (and pedestals), abutments and wing walls, piers, slopes and foundation elements.

### 1. Concrete Repairs

The repair of concrete substructures generally involves both cosmetic and structural rehabilitation. Cosmetic repairs include superficial concrete deterioration such as shallow spalling (defined by no exposed reinforcement) and delaminating concrete (i.e., incipient spalling). Structural repairs include flexural or shear cracking, cracks wider than 1/16" and deep spalling where reinforcement is exposed (regardless of the condition of the reinforcement).

Concrete repair limits shall be based on the latest field inspection documentation. This information shall be field verified if it is older than one year or if the limits of concrete deterioration are not well defined. When determining the limits of repair for both shallow and deep spalling, the outside dimensions of the defect shall be increased by a minimum of 6" on all sides to ensure that the deteriorated portion is encapsulated within the repair.

All concrete repairs shall include provisions to remove all loose and deteriorated concrete and thoroughly clean the remaining surfaces prior to placing the repair material. Any exposed reinforcement shall be blast cleaned and inspected for section loss. Any bar reinforcement that has sustained more than 20% section loss shall be replaced by reinforcement of equal size and adequately lapped/spliced to develop the full strength of the bar.

The material used to repair deteriorated concrete shall be selected based on the location, type and volume of the proposed repair.

### 2. Pile Repairs

Repairs to piles will consist of a combination of structural enhancement and/or protection. For existing steel piles with section loss resulting from corrosion, steel plates or rolled channel

section shall be field bolted to increase the capacity of the pile. Unless the pile has significant section loss, the addition of these steel elements can be affixed under full traffic load. The length of these newly bolted members shall extend well beyond the limits of the deteriorated portions so that the bolted connection is fully developed within the full original section of the pile. For concrete piles, additional concrete section may be added in a similar manner utilizing reinforcement doweled into the existing pile and tremie concrete placed. Repairs to timber piles that have lost section can be accomplished using timber pile splices.

Concrete and steel pilings shall be repaired by cleaning the exposed surfaces and placing fiberglass jackets from the channel bottom to up above the splash zone, or just in the vicinity of the splash zone if that distance is prohibitively long. Grout or a specialized concrete mix shall be placed between the existing pile and the jacket, with reinforcement added as needed to provide additional strength. Substantial cross-sectional losses can be strengthened by adding material to the pile and extending the concrete pile strut to the mudline. The foundation unit must be analyzed with this additional dead load to ensure that none of the piles are being overstressed by this additional weight.

### 3. Scour and Undermining

Channel degradation and/or scour can advance to the point of exposing the piles. In addition, strong waterway currents or wet/dry cycles can reduce the cross section of the piling at the channel bottom or mudline or water surface (common to timber piles and steel pipe piles). The foundation should be analyzed to determine the pile/soil interaction affects from lateral and vertical loadings and incorporate this information into a structural model to determine the overall structural integrity and/or stability of the foundation unit in question. Inspection observations and measurements or subsequent structural analyses will dictate if pile repairs should be performed in accordance with the previous section.

If scour countermeasures are deemed necessary, scour computations and evaluations shall be performed in accordance with the MDOT SHA OOS "Manual for Hydrologic and Hydraulic Design" (Ref. 12), in particular Chapter 7 and 11. In addition, an underwater inspection (including soundings) should be performed as well as a review of previous underwater inspection reports and other scour evaluation reports. Generally, scour countermeasures for bridges over streams, creeks and rivers will include riprap or grout bag blankets placed around piers and abutments. Stream instability countermeasures, if required, shall include riprap or gabion bank protection, spur dikes and check dams. Scour countermeasures for bridges over tidal waterways will include riprap aprons around pile bents and riprap revetments around abutments and approach roadways.

During the development of scour countermeasures, all permitting requirements shall be determined and applied for at the Preliminary Design phase.

#### 4. Underpinning

In extreme cases of undermining, a substructure unit may lose sufficient bearing, which could result in the structure collapsing. In the case where a substructure unit has rotated or settled, it may be necessary to jack the substructure unit back into proper position prior to underpinning the foundation. The method used to underpin a foundation depends greatly upon the amount of undermining and whether the underpinning is required to provide structural support. For severely undermined foundations, the underpinning must be performed in such a manner as to provide bearing. This can be accomplished by placing either a temporary form or a permanent fiberglass jacket around the substructure footing and pumping concrete or grout in the void between the substructure footing and the form. Reinforcing steel shall be doweled into the existing foundation or a rock foundation below. The form shall be high enough to provide sufficient head pressure so that the concrete or grout is forced into all voided areas and up against the bottom of the existing foundation. Constructing a cofferdam, dewatering the area, and constructing temporary forms is also another method which may be considered; however, this method results in considerable disturbance within

the waterway and is generally more costly and sensitive to permitting regulations.

For foundations where the undermining is minor and it has been determined that the remaining bearing area provides sufficient bearing capacity, pumping grout behind placed grout bags can be performed. The grout bags will prevent future undermining of the foundation while the grout pumped behind the grout bags will fill voids in which the bags could not fill.

#### D. Retaining Walls

The rehabilitation of retaining walls should consider the material and type of wall. For concrete retaining walls, repairs will generally only be made to the surface areas unless wall alignment is in question. Concrete repairs for retaining walls shall generally follow those stipulated for bridges under Section 3.11.C.1.

For the repair of MSE or other proprietary type precast walls, rehabilitation measures should be discussed with the wall manufacturer prior to implementing repairs. Typical problems involving MSE walls include the failure of the soil reinforcement strap attached to the wall facing panel. Grouted tie-back anchors may be considered to stabilize the wall panel and eliminate future local erosion of the fill.

Since gabion walls can tolerate substantial settlement and/or rotation prior to failure, repairs may only be necessary when the wire basket cages corrode or break. Retying the wires is an acceptable measure to repair the baskets. Gabion walls with substantial settlement and/or rotation shall be analyzed for stability to determine if the wall can remain or if reconstruction is required.

#### E. Maintenance of Traffic

Maintenance of Traffic (MOT) for the rehabilitation of existing structures shall conform to applicable portions of Chapter 5 as contained later within this volume.

## 3.12 Load Ratings

### A. Introduction

This section addresses the calculation of load ratings for new or existing structures as part of a design project to rehabilitate or replace an existing bridge. Load ratings may also be required for existing structures that have incurred structural deterioration observed during routine biennial inspections. Load ratings shall be calculated for all bridges carrying traffic including culvert type structures covered with less than 8 feet of earthen fill. As part of the final design of new or replacement bridges, the Designer shall compute the load ratings for the structure and include these with the Final Plans submittal to the County.

### B. Methodology

Load ratings shall be calculated in accordance with Chapter 6 of the latest edition of the AASHTO "Manual for Condition Evaluation of Bridges" (Ref. 14) and MDOT SHA Structural Guidelines and Procedure Memorandums" (Ref. 10). At a minimum, the four standard Maryland legal live load vehicles shall be rated, including the H-15 (15 tons), HS-20 (36 tons), Type T-4 (35 tons), and 3S-2 modified (40 tons) trucks. In addition, load ratings may be required for the eight (8) special vehicles (e.g., school buses, emergency vehicles, special permit vehicles, etc.) as directed by the County.

Both inventory and operating load rating values shall be computed for each truck considered. Material values shall be based on any available record plans or field testing, as applicable. If no plan or testing information is available, material properties shall be estimated based on the provisions contained within Chapter 6 of the latest edition of the AASHTO "Manual for Condition Evaluation of Bridges" (Ref. 14).

The inventory load rating value shall be considered as the load level that can safely cross the structure for an indefinite time period assuming that the structure remains in its current condition. The operating load rating value shall be considered as the maximum load level that can safely cross the bridge. Allowing this maximum load to cross the bridge indefinitely may compromise the structural integrity and limit the service life of the bridge.

Load ratings shall be computed based on the known section properties of each member accounting for any section loss or member deterioration that could adversely affect the load rating values. Load ratings may be hand-calculated or computed using appropriate computer software written specifically for structural load ratings. For rigid frames and box culvert type structures, structural models based on plane frame analysis methodologies shall be used. In addition to the application of dead and live loads, earth pressure loads (vertical and horizontal) shall be also be applied. Earth pressure loads shall be additive to the dead loads when computing the available member capacity to resist the applied live loads. For paved inverts that are structurally connected to the side walls (e.g., four-sided box culvert), the structural model shall incorporate the effects of the bottom slab loading on the subbase by utilizing spring constants in the model. These spring constants shall be based on an evaluation of the existing soil conditions to determine an appropriate coefficient of subgrade reaction. Each member within a four-sided culvert structure (i.e., walls, top slab and invert slab) shall be analyzed and load rated. Headwalls on rigid frame, four-sided culverts and pipes need not be load rated.

### C. Posting

Structures that do not rate out for the minimum vehicle weight at the inventory level (i.e., the rating factor,  $RF < 1.0$ ) shall be recommended for posting to the Chief of the Bureau of Engineering. All postings shall include both the Gross Vehicle Weight (GVW) for the H-15 and Type T-4 trucks and the Gross Combination Weight (GCW) for the HS-20 and Type 3S-2 modified trucks. The acceptance and implementation of the recommended load posting shall be at the discretion of the Chief of the Bureau of Engineering.

### 3.13 Plan Preparation Guidelines

#### A. Introduction

This section provides guidance on the proper manner to prepare plans for bridge replacement and/or rehabilitation projects. CADD guidelines related to the production of plan sheets using Microstation is covered under applicable sections of Chapter 1. Plan preparation guidelines for retaining wall projects are covered under Section 3.4.A.

#### B. Sheet Layout and Order

Bridge plan sheets shall be generated and prepared using commonly accepted engineering and drafting techniques and practices. In general, plan sheet layout shall be developed to include only those views, sections and details pertinent to a particular bridge component. Mixing of various details from different portions of the structure (e.g., substructure and superstructure) shall be avoided wherever possible.

The order of bridge plan sheets for new structures shall conform to the following:

- General Plan and Elevation
- Hydraulic and Hydrologic Data Sheet (if applicable)
- Geometric Layout (for substructure footings or piles)
- Substructure Unit Plan and Elevation (for abutments, wing walls and piers)
- Substructure Typical Sections (of abutments, wing walls and piers)
- Bridge Typical Section(s)
- Framing Plan Layout
- Beam/Girder Details (includes elevation, camber information, splice details, etc.)
- Diaphragm Details (end and intermediate)
- Bearings
- Deck Elevations
- Roadway Joint Details (includes plan layout, sections and any necessary details)
- Bridge Railing Details
- Approach Slab Layout and Sections (if applicable)
- Miscellaneous Details
- Boring Logs (including plan layout of locations)

The order of plan sheets for a rehabilitation project will follow this general order as applicable. Highway plan sheets and any necessary maintenance of traffic plan sheets shall be placed ahead of the bridge plans when they are made a part of the project.

### 3.14 References

- (1) "LRFD Bridge Design Specifications," American Association of State Highway and Transportation Officials (AASHTO)
- (2) "Manual for Railway Engineering," American Railway Engineering and Maintenance-of-Way Association (AREMA)
- (3) "Manual of Steel Construction," American Institute of Steel Construction (AISC)
- (4) "ACI Manual of Concrete Practice," American Concrete Institute (ACI)
- (5) "Structural Welding Code," AWS D1.1, American Welding Society (AWS)
- (6) "National Design Specification for Wood Construction," The American Wood Council (AWC)
- (7) "Howard County Storm Drainage Design Manual," Department of Public Works, Bureau of Engineering, Howard County, Maryland
- (8) "Hydraulic Design of Highway Culverts," Hydraulic Design Series No. 5, U.S. Department of Transportation, Federal Highway Administration
- (9) "Maryland Waterways Construction Guidelines," Maryland Department of the Environment
- (10) "Structural Guidelines and Procedure Memorandums," Maryland Department of Transportation, State Highway Administration, Office of Structures
- (11) "Structural Details Manual (Maryland Department of Transportation, State Highway Administration, Office of Structures
- (12) "Manual for Hydrologic and Hydraulic Design," Maryland Department of Transportation, State Highway Administration, Office of Structures
- (13) "SSPC Painting Manual, Volume 2," Society for Protective Coatings
- (14) "Manual for Condition Evaluation of Bridges," American Association of State Highway and Transportation Officials (AASHTO)
- (15) "Book of Standards for Highway and Incidental Structures," Maryland Department of Transportation, State Highway Administration, Office of Highway Development
- (16) "Guide Design Specifications for Bridge Temporary Works," American Association of State Highway and Transportation Officials (AASHTO)
- (17) "Construction Handbook for Bridge Temporary Works," American Association of State Highway and Transportation Officials (AASHTO)
- (18) "Bridge Scour and Stream Instability Countermeasures Experience, Selection, and Design Guidance," Hydraulic Engineering Circulars No. 23, U.S. Department of Transportation, Federal Highway Administration
- (19) "Hydraulic Design of Energy Dissipaters for Culverts and Channels," Hydraulic Engineering Circulars No. 14, U.S. Department of Transportation, Federal Highway Administration
- (20) "Stream Stability at Highway Structures," Hydraulic Engineering Circulars No. 20, U.S. Department of Transportation, Federal Highway Administration
- (21) "LRFD Guide Specifications for the Design of Pedestrian Bridges," American Association of State Highway and Transportation Officials (AASHTO)
- (22) "Guide Specifications for Wind Loads on Bridges During Construction," American Association of State Highway and Transportation Officials (AASHTO)
- (23) "Guide for the Development of Bicycle Facilities," American Association of State Highway and Transportation Officials (AASHTO)
- (24) "Standard Specifications for Highway Bridges," American Association of State Highway and Transportation Officials (AASHTO).
- (25) "Bridge Railing Manual," Maryland Department of Transportation, State Highway Administration, Office of Structures
- (26) "Aesthetic Bridges - User's Guide," Maryland Department of Transportation, State Highway Administration, Office of Structures
- (27) "Guide for Planning, Design and Operation of Pedestrian Facilities," American Association of State Highway and Transportation Officials (AASHTO)
- (28) "Roadway Lighting Design Guide," American Association of State Highway and Transportation Officials (AASHTO)

# CHAPTER 4

## Adequate Transportation Facilities Test Evaluation Requirements

### 4.1 PURPOSE ..... 4-1

### 4.2 REQUIREMENTS

- A. Projects Requiring Evaluation/Traffic Study Outside of the Downtown Columbia Area ..... 4-2
- B. Level of Service ..... 4-2
- C. Study Area ..... 4-2

### 4.3 TRAFFIC VOLUMES

- A. Existing Traffic Volumes ..... 4-3
- B. Projected Site-Generated Traffic Volumes ..... 4-3
- C. Projected Background Development ..... 4-3

### 4.4 ROADWAY CONDITIONS

- A. Existing Roadway Conditions ..... 4-4
- B. Proposed Roadway Conditions ..... 4-4
- C. Proposed Capital Program Improvements ..... 4-4

### 4.5 GENERAL COUNTY MITIGATION REQUIREMENTS

- A. Project Schedule Deferment ..... 4-5
- B. Project Scope Reduction ..... 4-5
- C. Roadway/Intersection Mitigation Plan ..... 4-5

### 4.6 TRANSITIONAL REQUIREMENTS ..... 4-7

### 4.7 EXEMPTIONS

- A. Exempt Non-Residential Projects ..... 4-8
- B. Exempt Residential Projects ..... 4-8

### 4.8 APPROVAL REQUIREMENTS

- A. Subdivision Approval ..... 4-9
- B. Site Development Plan ..... 4-9

### 4.9 REQUIREMENTS – DOWNTOWN COLUMBIA

#### 4.9.1 Evaluation Requirements

- A. Projects Requiring Evaluation/Traffic Study ..... 4-10
- B. Vehicle Level of Service ..... 4-10
- C. Pedestrian and Bicycle Level of Service Tests ..... 4-12
- D. Transportation Demand Management Statement ..... 4-12

#### 4.9.2 Downtown Columbia Mitigation Requirements

- A. Mitigation Option ..... 4-13
- B. Special Considerations ..... 4-15

#### 4.9.3 Other Relevant Sections ..... 4-15

#### 4.9.4 Monitoring ..... 4-15

#### 4.9.5 Cordon Line ..... 4-16

### APPENDIX

- I. Critical Lane Volume Analysis ..... 4-18
- II. Calculating Queue Length ..... 4-19
- III. Pedestrian and Bicycle Impact Test ..... 4-21

## 4.1 Purpose

This chapter of the Design Manual provides the guidelines for the preparation of the portion of the Traffic Study required pursuant to the Adequate Public Facilities requirements of the Subdivision and Land Development Regulations. The purpose of this portion of the Traffic Study is to determine the level of service of intersections and critical roadway segments within an impact area of a proposed subdivision or land development when the project is phased or completed.

The intent of the Adequate Public Facilities requirements is to direct new development to areas where road facilities are adequate and to require mitigation where deficiencies exist. The developer is required to analyze the intersections and critical links in the vicinity of the proposed development and pass the test for adequate transportation facilities as a condition of subdivision and land development approval.



## 4.2 Requirements

### A. Projects Requiring Evaluation/Traffic Study Outside of the Downtown Columbia Area

An Adequate Transportation Facilities Test Evaluation is required in most cases for property going through the subdivision and/or land development process and is to be submitted with the first submission to the County. The development must pass the test or have an approved mitigation plan, if necessary, to proceed through the process. This evaluation will show the traffic conditions on the collector and higher classified highway intersections in the vicinity of the project. The evaluation will be based upon the scheduled phase and/or completion year of the project. All projects that are not classified as comprehensive or phased are classified as Conventional Projects and the analysis time frame will be three years (e.g., 2005 - 2008) from the first submission to the County. Projects that are zoned new town, planned golf course community, mixed use, and R-A-15, and any zoning district with a planned development (P.D.) overlay are considered comprehensive projects and/or phased. For comprehensive and phased projects, the developer is required to submit a phasing and completion schedule, which will be the basis for establishing the test years.

For projects within the boundaries of Downtown Columbia, the standards and evaluation requirements found in Section 4.9 will be used in place of those found in this section (Section 4.2 A through 4.2 C). All other sections of this chapter will apply as noted.

### B. Level of Service

The intersection level of service (LOS) standard for this evaluation for County-controlled intersections is LOS D and the standard for State-controlled intersections is LOS E. The LOS evaluation shall be for the overall intersection.

The Intersection Standard for Downtown Columbia can be found in Section 4.9.

### C. Study Area

Projects are required to evaluate the designated intersections in the impact area of the site. The impact area of a project is defined below. Projects within Downtown Columbia shall refer to Section 4.9

- **IN PLANNED SERVICE AREA FOR PUBLIC WATER AND SEWER** - In that portion of the County in the Planned Service Area for Public Water and Sewer, an "Impact Area" means an area up to one and one-half road miles in all directions from each project entrance on a County or State road, but not beyond the intersection of a major collector or higher classified road with a major collector or higher classified road. The first intersection in all directions that meets this definition shall be evaluated.
- **IN NO-PLANNED SERVICE AREA FOR PUBLIC WATER AND SEWER** - In that portion of the County in the No-Planned Service Area for Public Water and Sewer, an "Impact Area" means an area up to two road miles in all directions from each project entrance on a County or State road, but not beyond the intersection of a minor collector or higher classified road with a minor collector or higher classified road. The first intersection in all directions that meets this definition shall be evaluated.

When a project's impact area crosses the Planned Service Area Boundary, the boundary limitations and intersection evaluation criteria will change to the applicable standards of the service area entered. Classifications of the roadway segments in the intersections will be governed by the General Plan Highways Map. The General Plan Highways Map will be used to establish which intersections will be analyzed in the Adequate Transportation Facilities Test Evaluation except as provided in Section 4.4.

## 4.3 Traffic Volumes

An Adequate Facilities Test Evaluation will be conducted in accordance with the procedures and technical standards identified in Chapter 5. Specific reference is made to the latest editions of the following publications: ITE Trip Generation Handbook, ITE Transportation Impact Analysis for Site Development, and ITE Trip Generation. Each intersection is required to be analyzed for the end of each scheduled phase and/or scheduled completion year of the project. The intersection will be tested with the traffic volumes that consist of the following components:

### A. Existing Traffic Volumes

Existing traffic volumes that have been field counted at the intersection as of the date the developer submits the application for approval of the project to the Department of Planning and Zoning.

### B. Projected Site-Generated Traffic Volumes

The project's projected site-generated traffic volumes at the intersection in the scheduled phase and/or completion years. Site-Generated Peak Hour trips shall be estimated based on the latest edition of Trip Generation, published by the Institute of Transportation Engineers (ITE) or trip generation studies approved by Howard County staff.

### C. Projected Background Development

#### 1. Unrecorded Previously Approved Development

Traffic volumes projected for the intersection from other proposed subdivisions and site development plans that have passed the test for adequate transportation facilities prior to the submission of the application for approval of the project but not yet recorded (if not previously counted).

#### 2. Recorded Previously Approved Development

Traffic volumes generated by subdivisions or site development plans that were recorded or approved prior to submission of the application for approval of the project and are scheduled to be completed before or during the scheduled phase and/or completion year of the proposed project (if not previously counted).

### 3. Background Traffic Growth Rate

Background traffic growth of 2% per year compounded shall be used unless adequate traffic data exists to support a different growth rate. The developer may propose or the Department may require different background traffic growth rates if validated field counts and other traffic data about the intersection support a different rate.

## 4.4 Roadway Conditions

The analysis of the intersections shall be based upon:

### A. Existing Roadway Conditions

Actual existing intersection conditions in existence as of the date the developer submits the application for approval to the Department of Planning and Zoning for the project.

### B. Proposed Roadway Conditions

New road facilities or improvements to existing road facilities that are included in developer's mitigation plans submitted prior to date of application of the project to the Department of Planning and Zoning. These plans shall be included in the evaluation if they are scheduled to be completed before or during the scheduled phase, and/or completion year of the proposed project.

### C. Proposed Capital Program Improvements

New road facilities or improvements to existing road facilities identified in the County's current Capital Program or extended Capital Program as defined in Title 22 of the Howard County Code and/or the Maryland Consolidated Transportation Program for which sufficient funds have been included so that the facilities will be substantially completed before or during the scheduled phase and/or completion year of the project, unless the Director of Public Works determines that such facilities or improvements are not likely to be completed by that time.

## 4.5 General County Mitigation Requirements

When the analysis of an intersection indicates operations will be below the adopted standards of Section 4.2, the developer shall revise the project with one or more of the following actions listed below. Intersections and roadways within Downtown Columbia shall follow the guidelines set forth in Section 4.9.

### A. Project Schedule Deferment

Defer the project until a future date when the Adequate Transportation Facilities Test Evaluation indicates that the level of service standard will not be exceeded.

### B. Project Scope Reduction

Reduce the scope of the proposed project to meet the level of service standard.

### C. Roadway/Intersection Mitigation Plan

Develop a mitigation plan for the intersection(s) that will increase the capacity on road facilities in the impact area so that the level of service after construction of the project would be equal to the level of service if the project had not been constructed but not more than the minimum level of service. Mitigation means the funding of improvements by the developer, approved by the Department, to off-site road facilities. Mitigation measures may include any intersection capacity improvement except grade-separation of the roadways and ramps within the intersection or improvements to the through lanes of intermediate arterial and higher classified roads. Please note the following:

- Existing Traffic Signal Modification: For existing traffic signal(s), mitigation may initially appear possible by adjustments in the signal phasing and/or timing. In reality, this is rarely possible due to signal coordination, storage of queued vehicles, etc. The developer is required to obtain advance approval from the agency responsible for the existing traffic signal maintenance prior to proposing modification to signal as a mitigation measure.

- Grade Separation: When grade separation of the intersection is the only viable mitigation alternative, full mitigation will not be required. When grade separation of an intersection or improvement to the through lanes is the only feasible alternative to providing mitigation, the County will program these improvements into the Capital Improvement Budget request for consideration of adoption. This request will be based upon receiving a payment in lieu of the cost of the partial mitigation from the developer.

#### 1. Shared Developer Mitigation Plan

When two or more developers are proposing mitigation plans for the same intersection, the Department will apportion the improvements between the parties based upon their proportion of the critical movements in the intersection. In the event that the timing of the development, technical infeasibility, or other factors do not allow the apportionment of the improvements, the Department shall collect from each developer the proportionate cost of the improvements corresponding to the development's proportion of the critical movements in the intersection. The funds collected will satisfy the developer's obligation for mitigation for the affected intersection. These funds will be collected on the basis that these funds will be programmed into a future Capital Project for the purpose of improving the intersection to mitigate the traffic generated by the multiple projects.

## 2. Capital Project Impact

When a developer's mitigation plan is proposed with a time frame that shows that a future capital project by the State and/or County will remove or negate the intersection improvements, the Department may waive the improvements and collect the estimated construction costs of the mitigation. These funds will then be programmed into a future Capital Project. Alternately, the improvements may be delayed to a certain date if a major facilities agreement is executed guaranteeing the improvements and the time schedule. If a proposed mitigation plan provides only temporary improvements due to proposed improvement plans for the road facility by others, a waiver may be granted for the improvements if the waiver does not cause traffic safety problems. In the event that a waiver is granted, the developer will be required to enter into a major facilities agreement to pay the cost of mitigation to the County, which will be used to help fund the cost of a Capital Project for future road facility improvements.

## 3. Constrained Roadway Impact

When a developer is required to evaluate a traffic capacity-constrained road facility, the Adequate Transportation Facilities Test Evaluation is still required. In the event that the level of service is below the standards in this manual, a mitigation plan is required. However, mitigation will be required to the extent that the mitigation plan improvements do not have a negative impact on the physical and right-of-way characteristics that have caused the constrained road facility to be designated. The developer may obtain the listing of constrained road facilities from the Department. The listing of constrained road facilities will be established by a resolution of the Howard County Council.

## 4.6 Transitional Requirements

If a project in the submission process has received sketch plan, preliminary plan, or final plan approval prior to the effective date of the Adequate Public Facilities Ordinance, an Adequate Transportation Facility Test Evaluation is not required provided that the project continues to meet the milestones established in the subdivision regulations.

If a project passes the test but is deferred because it cannot receive a school allocation, the Department may require an update of the data for Adequate Transportation Facility Test Evaluation and accompanying mitigation plan provided that the changes to the plan do not increase the cost of mitigation.

Once a subdivision has passed the Adequate Transportation Facilities Test Evaluation, no further approval for adequate transportation facilities for that project is required provided that the project's milestones are met, the developer executes a developer agreement and/or major facilities agreement for the proposed mitigation plan, the project is recorded, and in the case of site development plans, the traffic volume from the project does not exceed the traffic volume in the traffic study that formed the basis for passing the test during the subdivision plan approval process. If the traffic volume exceeds the volumes in the subdivision traffic study, the site development plan will be tested for the excess traffic.

However, projects within Downtown Columbia are subject to a 5-year monitoring study conducted and issued by the County. Specifically, in cases where a site development plan is submitted immediately after the issue date of the County study, and where, based on the findings of the County study, traffic data at test intersections are found to differ significantly from the assumptions projected by the traffic study that formed the basis for passing the Adequate Transportation Facility Test during the First Development Plan (FDP) stage of the subdivision process, then the FDP traffic study shall be modified using the most recently issued 5-year monitoring data as a guide. This modified study shall then be used as the basis for passing the Adequate Transportation Facility Test for each site development plan submitted after the County study issuance date. A Site Development Plan (SDP) submitted prior to the issuance of the first County 5-year study shall be subject to the traffic study submitted with the approved FDP. See Section 4.9.4 Monitoring.

## 4.7 Exemptions

Projects which do not generate any traffic are exempt from the requirement of submitting and passing the Adequate Transportation Facilities Test Evaluation. Site Development Plans which do not increase the traffic beyond what is already generated from the site at the time of application are exempt from submitting and passing the Adequate Transportation Facilities Test Evaluation. In order to obtain the exemption, an affidavit must be submitted and approved which provides an explanation of why no additional traffic is generated.

The Subdivision and Land Development regulations specify the minimum number of peak hour trips needed to require an Adequate Transportation Facilities Test Evaluation. In addition, the following projects are exempt from the requirements of passing the Adequate Transportation Facilities Test Evaluation:

### A. Exempt Non-Residential Projects

1. Non-Residential Subdivision Plans
  - a. A non-residential resubdivision (see subdivision regulations)
  - b. An exempt Government Facility, as follows:
    - 1) A facility to be owned or operated by the Federal Government, State Government, Howard County Public Schools, or any agency thereof.
    - 2) A facility owned by Howard County or any agency thereof where essential County Government services are provided, including police services, fire prevention and suppression services, emergency medical services, highway maintenance, detention facilities, water treatment and supply, sewage disposal and treatment, and solid waste disposal.
2. Non-Residential Site Development Plans
  - a. An exempt Government Facility as defined in Section 4.7.A.1.b.2). above.

### B. Exempt Residential Projects

1. Parcel Divisions (see Subdivision and Land Development Regulations)
2. Exempt Divisions (see Subdivision and Land Development Regulations)
3. Subdivisions in agricultural preservation districts for dwellings of the owner or the owner's child(ren).
4. Residential Resubdivisions (see Subdivision and Land Development Regulations) that do not increase the unit of housing units allowed.
5. Minor Subdivisions
6. Residential Site Development Plans previously tested in the subdivision process for single family attached and detached housing.



## 4.8 Approval Requirements

### A. Subdivision Approval

Once a subdivision has been approved for Adequate Transportation Facilities, no further approval for Adequate Transportation Facilities for that project is required during the subdivision or site development plan approval process, provided that:

1. The developer continues to meet all required milestones;
2. The developer executes a major facilities agreement for any proposed mitigation;
3. The project proceeds to recordation and is recorded; and,

The traffic volume from the project in the site development plan traffic study does not exceed the traffic volume in the projected traffic study that formed the basis for passing the Adequate Transportation Facilities Test during the subdivision plan approval process. If the traffic volume in the site development plan exceeds the traffic volume in the subdivision traffic study, the site development plan will be tested for the excess traffic only. This provision does not apply in Downtown Columbia.

Exception:

Projects within Downtown Columbia are subject to a 5-year monitoring study conducted and issued by the County. Specifically, in cases where a site development plan (SDP) is submitted immediately after the issue date of the County study, and where, based on the findings of the County study, traffic data at test intersections are found to differ significantly from the assumptions projected by the traffic study that formed the basis for passing the Adequate Transportation Facility Test during the first development plan (FDP) stage of the subdivision process, then the FDP traffic study shall be modified using the most recently issued 5-year monitoring data as a guide. This modified study shall then be used as the basis for passing the Adequate Transportation Facility Test for each site development plan submitted after the County study issuance date. A SDP submitted prior to the issuance of the first county 5-year study shall be subject to the traffic study submitted with the approved FDP. See Section 4.9.4 Monitoring.

### B. Site Development Plan

Once a site development plan has been approved for Adequate Transportation Facilities, no further approval for Adequate Transportation Facilities is required, provided that the developer executes a developer agreement and/or a major facilities agreement for any proposed mitigation or as stipulated in the exception above.

## 4.9 Requirements - Downtown Columbia

### 4.9.1 Evaluation Requirements

#### A. Projects Requiring Evaluation/Traffic Study

This section shall be used in place of Section 4.2, Requirements, for development projects located within Downtown Columbia as defined in the New Town Zoning Regulations. All other sections of Chapter 4 remain applicable to the projects as noted.

An Adequate Transportation Facilities Evaluation consists of a series of tests and is required for most property going through the subdivision and/or land development process. It is to be submitted with the first submission to the County. This evaluation determines the development impact on traffic conditions in the vicinity of the project and will be based upon the scheduled phase and/or completion year of the project. The development must pass the tests or have an approved mitigation plan to proceed through the process. Developments located within Downtown are considered comprehensive and/or phased projects. Construction or implementation of improvements in the mitigation plan must appropriately coincide with the phasing and occupancy schedule.

#### B. Vehicle Level of Service Test

##### 1. Minimum Trip Threshold

All new developments in Downtown Columbia projected to generate 20 or more net peak hour trips must submit a traffic study. Developments projected to generate less than 20 net peak hour trips may be required to submit a traffic study if the existing Critical Lane Volume (CLV) at the test intersection is greater than CLV 1500. The CLV may be determined by county monitoring study or the most recently accepted and approved APF study.

#### 2. Impact Area

At a minimum, the traffic study shall determine the CLV of the nearest intersection in all directions and the next closest signalized intersections in accordance with Table 1 below.

**TABLE 4-1  
SIGNALIZED INTERSECTIONS TO BE INCLUDED IN THE TRAFFIC STUDY**

Net Peak Hour Site Trips	Minimum Number of Signalized Intersection in Each Direction
20 – 100	1
101 – 500	2
501 – 800	3
800 – 1500	4
>1500	5

The impact area is limited to intersections within the Cordon Line as it is defined in Section 4.9.5. Additional intersections or significant driveway locations within the Cordon Line and impacted by the new development may be required in the traffic study by the Department of Planning and Zoning and Department of Public Works. In the event that the minimum number of signalized intersections to be tested, as indicated in Table 1, extends beyond the Cordon Line then only those intersections within the Cordon Line will be evaluated regardless of number.

#### 3. Intersection Standard

The intersection standard within the Cordon Line, as defined in Section 4.9.5., shall not exceed CLV 1600 for the overall intersection. This standard is subject to a transitional CLV requirement. During the transition phase to CLV 1600, all Downtown intersection testing and mitigation will be subject to the following:

- (A) All Downtown intersections must be evaluated and, if necessary, mitigated per Section 4.9.2 using an initial CLV of 1500.

- (1) In the event the sum of existing and projected background traffic volumes (Total Projected Background Traffic) result in a CLV exceeding 1500 before the addition of site generated Net Peak Hour Trips, then the acceptable CLV standard for mitigation at the subject intersection will be the CLV as determined by Total Projected Background Traffic.
  - (2) If it is determined by DPZ/DPW that:
    - (I) An intersection cannot be improved to the applicable CLV standard as described above or,
    - (II) The proposed improvement to attain the applicable CLV standard does not satisfy the design balance as further discussed in Section 4.9.2 or
    - (III) Mitigation of the intersection to the applicable CLV standard would require the construction of an improvement which DPZ, in consultation with DPW, finds not to be necessary to maintain an intersection CLV of no more than 1600 at the time of full buildout of the Downtown Columbia Plan,
- (B) In no case shall the incremental adjustment of the intersection CLV exceed 1600.
  - (C) When analyzing intersections for the traffic study, the latest version of Maryland State Highway Administration's (MSHA) Critical Lane Volume (CLV) analysis procedures must be used, the methodology will fit most intersection configurations and can be varied easily for special situations and unusual conditions. The methodology is also described in the Appendix.

then, the applicable CLV standard will increase by increments of 50 until the conditions identified in both (I) and (II) above are no longer true. Thereafter, the adjusted intersection CLV will then become the new accepted CLV standard for that intersection and will be used as the initial CLV for subsequent evaluations of that intersection under paragraphs (A)(1) and (2) of this Subsection, 4.9.1.B.3.

#### 4. Queuing Analysis Test

In addition to a CLV test at applicable intersections, a queuing analysis shall also be performed on all approaches of the same intersections, and shall include left turn and through movements. Queue length shall be calculated during the weekday peak hours using the procedures found in the Appendix. For signalized intersection spacing greater than 300 feet, the queue shall not exceed 80 percent of the distance between signalized intersections. For signalized intersection spacing less than 300 feet, the queue shall not exceed more than 90 percent of the distance to an adjacent signalized intersection.

If the queue exceeds the specified standard, then it shall be treated as insufficient capacity and must be addressed under the mitigation plan.

#### 5. Traffic Volumes

An Adequate Facilities Test Evaluation will be conducted in accordance with the scope, procedures, and technical standards identified in Chapter 5. Specific reference is made to the latest editions of the following publications: ITE Trip Generation Handbook, ITE Transportation Impact Analysis for Site Development, and ITE Trip Generation.

Site-Generated Peak Hour trips shall be estimated based on the latest edition of Trip Generation, published by the Institute

of Transportation Engineers (ITE) or trip generation studies approved by Howard County. Net Peak Hour Trips are defined as Site-Generated Trips minus appropriate reductions for internal trips, non-auto trips (i.e., transit, bike, walking, and/or other non-auto trips), transportation demand management (TDM) trip reductions, and pass-by/diverted-link trips in accordance with the references cited above. Test intersections in the impact area, as described by Table 1, are required to be analyzed for the end of each scheduled phase and/or scheduled completion year of the project. Section 4.3, Traffic Volumes, is applicable to intersections within Downtown Columbia and shall be used to determine traffic volumes.

**6. Roadway Conditions**

The analysis of intersections shall be based upon the guidelines previously established in Section 4.4 Roadway Conditions, Parts A through C.

**C. Pedestrian and Bicycle Level of Service Tests**

All new developments must satisfy a Pedestrian Level of Service (PLOS) no less than PLOS C, and a Bicycle Level of Service (BLOS) no less than BLOS C for any study segment identified as a bicycle route on the Bicycle and Pedestrian Circulation Plan in the Downtown Columbia Plan or a County approved bicycle plan. The study must evaluate existing and proposed sidewalks, crossings and bicycle facilities along the study segment.

The Pedestrian Level of Service (PLOS) and Bicycle Level of Service (BLOS) shall be calculated as shown in the Appendix. However, if it is the finding of DPZ/DPW that (i) a reasonable alternative bicycle or pedestrian route exists or is proposed, or (ii) meeting the BLOS or PLOS Standard would negatively impact the BLOS, PLOS, or the design balance as further discussed in Section 4.9.2, then the BLOS or PLOS test, as appropriate, is deemed satisfied.

**D. Transportation Demand Management Statement**

A Transportation Demand Management (TDM) statement shall be provided with each traffic study. The statement will discuss appropriate TDM strategies for the development program planned in the FDP or SDP, how they may be implemented, and how the proposed selected strategies and implementation would complement any current Downtown Transportation Demand Management Plan developed under Section 2.4 of the Downtown Columbia Plan. The statement should also discuss the status of past initiatives, if applicable. Statements shall address strategies to reduce automobile travel and promote alternative means of mobility to and from the proposed development. A typical statement will encourage alternative means of mobility through promotional incentives and programs, transit contributions such as contributions to a circulator system, new bus routes, higher frequency of service and improved stops and service information, enhancements to the connections between Downtown Columbia and the Village Centers and areas outside of Downtown Columbia, including transit right-of-ways, off-site bicycle and pedestrian facilities improvements or other measures. The scale of the TDM statement shall reflect the number of trips generated by the development and the remaining capacity of the transportation facility.

**4.9.2 Downtown Columbia Mitigation Requirements**

In order to obtain Departmental approval, the mitigation plan shall address the findings of the vehicle, pedestrian and bicycle level of service tests as well as the inclusion of the TDM statement. All mitigation plans are required to incorporate a design balance between safety, mobility, modes of transportation, scale and character of the surrounding area, aesthetics, and the County General Plan.

If it is the finding of the Directors of Planning and Zoning and Public Works that a proposed mitigation plan does not satisfactorily address the design balance described above then the County reserves the right to require modifications to the proposed mitigation plan.

Also, the developer shall be required to submit a phasing and completion schedule. Implementation of improvements in the mitigation plan must appropriately coincide with the significant milestones in the phasing and completion schedule that required the mitigation.

**A. Mitigation Options:** When analysis of an intersection indicates CLV values exceeding the requirements of Section 4.9.1.B.3. Intersection Standard, the developer shall revise the project as indicated by the following.

**1. Roadway/Intersection Mitigation Plan**

Develop a mitigation plan for the intersection(s) that will increase the capacity on road facilities in the impact area so that the level of service after construction of the project will be equal to or better than the level of service/CLV required under Section 4.9.1.B.3. Mitigation means full funding of improvements by the developer, approved by the Department, to off-site road facilities. Mitigation measures may include any intersection capacity improvement except grade-separated roadways and ramps within intersections, or improvements to through lanes of roads classified as intermediate arterials or higher. Please note the following:

(A) Existing Traffic Signal Modification:  
For existing traffic signal(s), mitigation

may initially appear possible by adjustments in the signal phasing and/or timing. In reality, this is rarely possible due to signal coordination, storage of queued vehicles, etc. The developer is required to obtain advance approval from the agency responsible for the existing traffic signal maintenance prior to proposing modification to a signal as a mitigation measure.

(B) Grade Separation:

- (1) Construction of a third grade-separated interchange on Route 29 shall not be required to achieve a CLV of less than 1600.
- (2) When grade-separated roadways or arterial through lane improvements are the only viable mitigation alternatives, full mitigation will not be required by the developer but may be provided. If full mitigation is not provided then final department signature of the approved site development plan will not occur until:
- (3) The project is fully funded in the approved Capital Budget with construction initiating within 3 years after budget approval and
- (4) A major facilities agreement has been executed outlining the improvement cost share, comparative construction schedules between the improvement and the development project, and other terms and conditions as applicable between the parties.

**TABLE 4-2  
NON-AUTOMOBILE TRIP CREDITS**

Non-Automobile Transportation Facility	Trip Credit Per Peak Hour Trip
100 Linear Feet of Off-Site Five-Foot Wide Sidewalk	5
100 Linear Feet of Off-Site Ten-Foot Wide Shared Use Path	5
Off-Site Curb Extension/Pedestrian Refuge Island/Handicap Ramp	2
Off-Site Accessible Pedestrian Pushbuttons (set of two each leg)	3
Off-Site Countdown Pedestrian Signal Head (set of two each leg)	3
Off-Site Signalized Pedestrian Crosswalk (includes APS, Countdown Heads, Pavement Markings each leg)	7
Bike Rack (set of 8)	2
Bus Shelter	3
Information Kiosk	2
Bike Lockers (set of 8)	3
Real-time Transit Information Sign	2
Static Transit Information Sign	0.5
Shuttle or Bus	5-15
Bus Pullout	3
<b>Maximum Trip Credits</b>	<b>50</b>

The time frame to reach the major facilities agreement will be 3 years from the date of the site development plan submission. If an agreement cannot be executed within that time, then any of the following may be considered:

- (I) A 1-year extension may be granted,
- (II) Terms of the agreement may be mutually modified by the parties,
- (III) A modified site development plan may be submitted,
- (IV) The site development plan may be withdrawn without prejudice.

**2. Non-Automobile Trip Credits:** In order to enhance pedestrian safety and to encourage transit and bicycle use, trip credits are allowed if a developer improves an existing or provides a new non-automobile (pedestrian, bicycle, transit or transportation demand management) facility or program not otherwise required according to Table 2. Use of the trip credits and determination of the amount with in a range of the credit is at the discretion and approval of the Department of Planning and Zoning as deemed to promote mobility to, in and around the Downtown area.

**3. Project Scope Reduction**

Reduce the scope of the proposed project to meet the level of service standard.

**4. Project Schedule Deferment**

Defer the project until a future date when the Adequate Transportation Facilities Test Evaluation indicates that the level of service standard will not be exceeded.

**B. Special Considerations**

**1. Shared Developer Mitigation Plan**

(A) When two or more developers are proposing separate mitigation plans for the same non-grade separated intersection or non-arterial through lane, the Department may apportion the improvements between the parties based upon their proportion of the critical movements in the intersection. In the event that timing of the development, technical infeasibility, or other factors do not allow the apportionment of the improvements, the Department shall collect from each developer the proportionate cost of the improvements corresponding to the development's proportion of the critical movements in the intersection. The funds collected will satisfy the developer's obligation to mitigate the affected intersection. These funds will be collected on the basis that they will be programmed into a future Capital Project for the purpose of mitigating traffic generated by the multiple projects at the test intersections. However, final approval of the site development plan will not occur until:

- (1) The project is fully funded in the approved Capital Budget with construction initiating within 3 years after budget approval, and
- (2) A major facilities agreement has been executed outlining the improvement cost share, comparative construction schedules between the improvement and the development project, and other terms and conditions as applicable between the parties.

The time frame to reach the major facilities agreement will be 3 years from the date of the site development plan submission. If an agreement cannot be executed within that time, then any of the following may occur:

- (I) A 1-year extension maybe granted,
- (II) Terms of the agreement may be mutually modified by the parties,
- (III) A modified site development plan may be submitted,
- (IV) The site development plan may be withdrawn without prejudice.

(B) Alternatively, developers of multiple projects may jointly propose a mitigation plan for purposes of meeting the Adequate Transportation Test Requirement. Each mitigation plan must indicate the participants in the plan; which participant(s) will be responsible for implementing the plan and constructing any required transportation improvement; and how the transportation capacity to be created will be apportioned among the plan participants.

**4.9.3 Other Relevant Sections**

Other relevant sections of the Adequate Transportation Public Facilities Test Evaluation requirements that apply to developments in Downtown Columbia are listed here for clarity.

4.6 Transitional Requirements

4.7 Exemptions

4.8 Approval Requirements

**4.9.4 Monitoring**

The County will conduct independent traffic monitoring studies every 5 years, the first monitoring study will occur 5 years after submission of the first subdivision plan (FDP) for the Downtown Columbia area. The final study will be issued as specified in the Howard County Code. The date the study is issued will be the issuance date for



purposes of Section 4.6 Transitional Requirements and Section 4.8 Approval Requirements. The monitoring studies will be a comprehensive assessment of existing transportation facilities within the Downtown Columbia area. The purpose of the monitoring study will be to validate and/or recalibrate projections made in the redevelopment traffic study (September 2008 Columbia Town Center Generalized Traffic Study) and/or subsequent studies submitted with future subdivision final development plans and/or site development plans, and that form the basis of the proposed development program. Refer to Section 4.6 Transitional Requirements and Section 4.8 Approval Requirements for the application of the monitoring study to the FDP and SDP submittal process.

The study will include an analysis of the following:

Traffic Signal Optimization

Comprehensive Traffic Study HCM and CLV

Transit Ridership

Cordon Line Study –  
Total in/out,  
Historical growth,  
Directional split,  
Vehicle classification,  
Vehicle occupancy,  
Analyze Downtown TDM data provided by others

Interchange ramp weaves and merges

Travel Demand Sub-Area Modeling

The studies will measure or validate:

Intersection STANDARD – DPW

Trip distribution/diversion – DPW

Transit Ridership – DPZ

Modal Split - DPW/DPZ

Internal trip capture rate - DPW with TDM data supplied by others

Background traffic rate – DPW  
(define in Section 4.3.C.3)

Regional transportation impacts including interchanges

When the monitoring study indicates significant differences between County determined values and those used in the development traffic studies, the developer shall revise the traffic study with one or more of the following actions:

1. Obtain new data for all intersections in the development impact area to recalculate the CLV.
2. Modify background traffic growth rate.
3. Modify internal trip rate
4. Modify modal split reductions
5. Modify pass-by trip rate– estimations supplied by TDM data
6. Reevaluate trip distribution/diversion percentages

Based on the new data for the traffic study and the subsequent reevaluation of intersections in the impact area, the developer shall revise the mitigation plan as outlined in Section 4.9.2.

**4.9.5 Cordon Line**

The Cordon Line defines the basic limits of traffic studies within Downtown Columbia. Additionally, the Cordon Line identifies critical locations to monitor total amounts of traffic entering and leaving the Downtown area (see Figure 1).

Current base line trips are maintained and available from the Department of Planning and Zoning. Net Peak Hour Trips generated by each new development will be added to the current base line and shall not exceed the applicable cap established by background, growth and total new development trip volume. Current Cordon Line Locations are as follows:

Adequate Transportation Facilities Test Evaluation Requirements

1. Little Patuxent Parkway East of Columbia Road and west of the Route 29 ramps
2. Columbia Road just North of Little Patuxent Parkway
3. West Running Brook Road just North of Little Patuxent Parkway and prior to Hyla Brook Road
4. Windstream just North of Governor Warfield Parkway and prior to Placid Lake Road
5. Twin Rivers Road just North of Governor Warfield Parkway and prior to Daystar Court
6. Little Patuxent Parkway just West of Governor Warfield Parkway/Banneker Road
7. Hickory Ridge Road just West of Broken Land Parkway and prior to Martin Road
8. Broken Land Parkway South of Hickory Ridge Road and West of the Route 29 ramps
9. South Entrance Road just South of Symphony Woods Road and West of the Route 29 ramps

As newly constructed roadways intersect the Cordon Line, new roadway locations shall be added.

Figure 1. Cordon Line Locations.



**APPENDIX****(I) Critical Lane Volume Analysis**

An applicant can use the following procedure at signalized or unsignalized intersections. For unsignalized intersections, a two-phase operation should be assumed. The traffic volumes used in the analysis are those approaching the intersection as determined in each step of the traffic study (existing, existing plus background, and existing plus background plus site). The following steps describe how to determine the CLV of an intersection with a simple two-phase signal operation.

- Step 1. Determine the signal phasing, number of lanes, and the total volume on each entering approach to an intersection and the traffic movement permitted in each lane.
- Step 2. Subtract from the total approach volume any right-turn volume that operates continuously throughout the signal cycle, (a free-flow right-turn by-pass). Also, subtract the left-turn volume if it is provided with an exclusive lane.
- Step 3. Determine the maximum volume per lane for each approach by multiplying the volume calculated in Step 2 by the appropriate lane-use factor selected from the lane use factor table below. (Note: Do not count lanes established for exclusive use such as right- or left-turn storage lanes – the lane use factor for a single exclusive use lane is 1.00.)
- Step 4. Select the maximum volume per lane in one direction (e.g., northbound) and add it to the opposing (e.g., southbound) left turn volume.
- Step 5. Repeat Step 4 by selecting the maximum volume per lane in the opposite direction (e.g., southbound) and the opposing (e.g., northbound) left-turn volume.
- Step 6. The higher total of Step 4 or Step 5 is the critical volume for phase one (e.g., north-south).
- Step 7. Repeat Steps 4 through 6 for phase two (e.g., east-west).

- Step 8. Sum the critical lane volumes for the two phases to determine the CLV for the intersection. (Note: At some intersections, two opposing flows may move on separate phases, for these cases, each phase becomes a part of the intersection's CLV.)

**Special Cases**

Where the right lane is devoted to the exclusive use of right turn vehicles, a maximum lane volume should be computed separately for through movements and right turn movements. If a right turn phase overlap is provided with a left turn phase on the cross street, subtract the overlapping left turn volume from the right turn volume. The highest of the through or right turn lane volumes should be added to the opposing left turn volume, except where significant right turns on red occur.

**Free Right**

A free right turn is one which is not controlled by the traffic signal or stop sign. Normally the movement is isolated by a channelizing island and controlled by a yield sign. If the right turn movement is serviced by an exclusive right turn lane of sufficient length that right turning vehicles are not part of the queue of thru vehicles, the right turning volumes can be excluded from the critical lane analysis. Knowledge of the intersection can be used to combine a sufficient number (percent) of the right turns with the thru traffic to reflect actual peak hour operations. In the absence of such knowledge a queuing analysis could be done. As a rule-of-thumb 150 feet of exclusive right turn lane will permit excluding all right turns; less than 50 feet will require that all rights be included. Distances within that range suggest that a portion of the right turn volume be included.

**Right Turn on Red**

The number of vehicles which can take advantage of the RTOR feature vary greatly based on site and traffic characteristics. At higher volume intersections, as the Level-of-Service diminishes, few gaps are generally available for RTOR. Unless observations of the RTOR operations support excluding some right turns from the Critical Lane Analysis, this feature will normally not be considered.

**No Separate Left Turn Lane**

On multi-lane approaches with no separate left turn lane the impact of left turning traffic may be significant, especially on high volume roadways. Typically, the left lane operates as a left turn lane with nearly all thru traffic avoiding this lane. Calculations for such an approach should be as follows:

The left turn volume will be adjusted using the PCE Factor (shared lane) of the 1985 HCM Pages 9-35. The opposing volume will be total through traffic and rights. When the adjusted left turn volume is greater than the remaining volume being included in the analysis, the left most lane will be considered an exclusive left turn lane. The analysis will proceed with that assumption. For other cases, the resulting left turn volume will be added to the rest of the approach volume and the appropriate lane use factor applied to the total.

**One Lane Approaches**

Where a bypass of left turning vehicle is available the one lane approach should be treated as if there is a separate left turn lane. If no bypass area is available traffic on the one lane approach can proceed only when there is no vehicle waiting to turn left. This case should be analyzed using PCE (shared lane) equivalencies (1985 HCM pages 9-35) to modify the left turn volumes. The resulting total will be added to the rest of the approach volume and the appropriate lane use factor applied.

**Double Left Turn Lanes**

Both the access to the double left turn lane and movements made immediately after the left turn will influence the distribution of traffic between the available lanes. Generally, the distribution is less balanced than for thru lanes; thus, the recommended lane use factor of 0.60. Variations observed at specific sites may suggest the use of different factor for this movement.

**Lane Use Factors**

Lane Use Factors are to be as follows:

**TABLE A-1  
LANE USE FACTORS**

Number of Lanes	Factor
1	1.00
2	.55
3	.40
4	.30
DBLLT	.60

**(II) Calculating Queue Length**

For Signal Cycle Length less than 120 seconds

- Queue length = 1.25 x Volume

For Signal Cycle Length, greater than 120 seconds

Procedures for determining queue lengths at signalized and unsignalized intersections:

**A. Signalized Intersections**

This Procedure can be used at intersections with existing signals and intersections where it is felt a signal may be installed.

1. Perform critical lane analysis
2. Select Cycle length
  - Use existing timing if available
  - If timing is not available, use the suggested cycle lengths

**TABLE A-2  
RECOMMENDED MAXIMUM CYCLE LENGTHS**

LOS	2 Phase	3-5 Phase	6-8 Phase
A	90	100	120
B	90	100	120
C	100	120	135
D	120	135	150
E	135	150	165
F	150	165	180

**TABLE A-3**  
**POISSON DISTRIBUTION FOR VEHICLES PER CYCLE**

Average No. of Vehicle per Cycle	Maximum No. of Vehicle per Cycle
0.1 – 0.3	1
0.4 – 0.8	2
0.9 – 1.3	3
1.4 – 1.9	4
2.0 – 2.6	5
2.7 – 3.2	6
3.3 – 3.9	7
4.0 – 4.7	8
4.8 – 5.4	9
5.5 – 6.1	9
6.2 – 6.9	10
7.0 – 7.7	11
7.8 – 8.4	12
8.5 – 9.2	13
9.3 – 10.0	14
10.1 – 10.8	15
10.9 – 11.6	16
11.7 – 12.4	17
12.5 – 13.2	18
13.3 – 14.0	19
14.1 – 14.9	20
15.0 – 15.7	21
15.8 – 16.5	22
16.6 – 17.3	23
17.4 – 18.2	24
18.3 – 19.0	25
19.1 – 19.8	26
19.9 – 20.0	27

3. Note: These cycle lengths are to be used as a guide, knowledge of the intersection may result in using a higher or lower cycle.

4. Use Poisson Distribution Chart/Formula to determine maximum number of vehicles per cycle of a specific movement.

Formula:

$$\text{Avg. Vehicle/Cycle} = \frac{\text{Critical Lane Volume (veh/hr)} \times \text{Cycle Length (sec)}}{3600 \text{ (sec/hr)}}$$

5. Assume a Vehicle Length of 25 ft.

6. Once the average vehicles per cycle (specific movement) is determined, the chart can be used to find the maximum vehicles per cycle for that movement.

7. The queue length will be the maximum vehicles per cycle times 25 ft. per vehicle.

8. It is noted that the chart ends at an average of 20 vehicles per cycle. In cases where the average number of vehicles per cycle exceeds 20 the following formula can be used to determine the queue length. This formula can also be used in lieu of the chart.

$$Q = \text{Avg. No. of Vehicles} \times 1.4 \text{ (Surge Factor)} \times 25 \text{ (ft)}$$

**B. Unsignalized Intersection**

This procedure can be used at isolated intersections where it is felt a signal will not be placed. If there is any chance that a signal may be placed at an intersection, the procedure for signalized intersections should be used.

1. Determine the critical gap needed for the movement (from chart) this chart is also found in the 1985 HCM unsignalized intersections.

**TABLE A-4  
BASIC CRITICAL GAP FOR PASSENGER CARS, SEC**

VEHICLE MANEUVER AND TYPE OF CONTROL	VEHICLE RUNNING SPEED MAJOR ROAD			
	30 MPH		55 MPH	
	NUMBER OF LANES ON MAJOR ROAD			
	2	4	2	4
RT FROM MINOR ROAD				
STOP	5.5	5.0	5.5	5.0
YIELD	6.5	5.5	6.5	5.5
LT FROM MAJOR ROAD				
	5.0	5.5	5.5	6.0
CROSS MAJOR ROAD				
STOP	6.0	5.5	6.5	6.0
YIELD	7.5	6.5	8.0	7.0
LT FROM MINOR ROAD				
STOP	6.5	6.0	7.0	6.5
YIELD	8.0	7.0	8.5	7.5

2. Note: If restricted sight distance exists add one second to the gap needed. Where average running speeds are between 30 mph and 55 mph, interpolate.
3. Determine average gap between opposing vehicles

$$\text{Average Gap Between Opposing Vehicle} = \frac{3600}{\text{volume/hour}}$$

4. If the average gap is greater than the gap needed for the maneuver the same

procedure as signalized intersections can be used with the cycle length equal to the critical gap required (from chart) plus 4 seconds (start-up time).

5. If the average gap is less than or equal to the gap needed, this maneuver should be analyzed as if a signal were in place.

**(III) Pedestrian and Bicycle Impact Test**

A Pedestrian Level of Service (PLOS) and Bicycle Level of Service (BLOS) shall be computed using the PLOS and BLOS equations and the Pedestrian and Bicycle LOS categories from Table 6 below. The acceptable PLOS and BLOS for Downtown Columbia is PLOS C and BLOS C.

Unlike the PLOS and BLOS methodologies described in the Highway Capacity Manual, these methodologies take into account the existence of sidewalks, lateral separation of pedestrians from motorized vehicles, average effective width of the outside through lane, motorized vehicle volumes, motorized vehicle speeds, heavy vehicle (truck) volumes, and pavement condition. If it is the finding of DPZ/DPW that (i) a reasonable alternative bicycle or pedestrian route exists or is proposed, or (ii) meeting the BLOS or PLOS Standard would negatively impact the BLOS, PLOS, or the design balance as further discussed in Section 4.9.2, then the BLOS or PLOS test, as appropriate, is deemed satisfied.



The Pedestrian Level of Service (PLOS) score is calculated using the following equation:

$$\text{PLOS score} = -1.2276 \text{ LN} [(W_{ol} + W_L + (F_P \times \% \text{OSP})) + ((F_B \times W_B) + F_{sw} \times W_s)] + 0.0091(\text{Vol}_{15}/L) + 0.0004 \text{ SPD}^2 + 6.0468$$

Where:

- PLOS = Pedestrian level of service score
- LN = Natural log
- $W_{ol}$  = Width of outside lane
- $W_L$  = Width of shoulder or bicycle lane
- $F_P$  = On-street parking effect coefficient (=0.20)
- % OSP = percent of segment with on-street parking
- $F_B$  = Buffer area barrier coefficient (=5.37 for trees spaced 20 feet on center)
- $W_B$  = Buffer width (distance between edge of pavement and sidewalk, feet)
- $F_{sw}$  = Sidewalk presence coefficient (=6-0.3 $W_s$ )
- $W_s$  = Width of sidewalk
- $\text{Vol}_{15}$  = Volume of motorized vehicles in the peak 15-minute time period
- L = Total number of directional through lanes
- SPD = Average running speed of motorized vehicles traffic (mi/hr)

The Bicycle level of service (BLOS) is calculated using the following equation:

$$\text{BLOS score} = 0.507 \text{ LN}(\text{Vol}_{15}/L) + 0.199 \text{ SP}_T (1 + 10.38 \text{ HV})^2 + 7.066 (1/ \text{PR}_5)^2 - 0.005 (W_E)^2 + 0.760$$

Where:

- BLOS = Bicycle level of service score
- LN = Natural log
- $\text{Vol}_{15}$  = Volume of directional motorized vehicles in the peak 15-minute time period
- L = Total number of directional through lanes

- $\text{SP}_T$  = Effective speed factor =  $1.1199 \text{ LN} (\text{SP}_P - 20) + 0.8103$
- $\text{SP}_P$  = Posted speed limit (a surrogate for average running speed)
- HV = Percentage of heavy vehicles
- $\text{PR}_5$  = FHWA's five-point pavement surface condition rating
- $W_E$  = Average effective width of outside through lane

Where:

- $W_E = W_v - (10\text{ft} \times \% \text{OSP})$  where  $W_1 = 0$
- $W_E = W_v - W_1 (1 - 2 \times \% \text{OSP})$  where  $W_1 > 0$  &  $W_{ps} = 0$
- $W_E = W_v + W_1 - 2 (10 \times \% \text{OSP})$  where  $W_1 > 0$  &  $W_{ps} > 0$  and a bicycle lane exists

Where:

- $W_t$  = total width of outside lane (and shoulder) pavement
- %OSP = percentage of segment with occupied on-street parking
- $W_1$  = width of paving between the outside lane stripe and the edge of pavement
- $W_{ps}$  = width of pavement striped for on-street parking
- $W_v$  = effective width as a function of traffic volume

**TABLE A-5  
PEDESTRIAN AND BICYCLE LOS CATEGORY**

Level of Service	PLOS/BLOS Score
A	≤1.5
B	>1.5 and ≤ 2.5
C	>2.5 and ≤ 3.5
D	>3.5 and ≤ 4.5
E	>4.5 and ≤ 5.5
F	>5.5



# CHAPTER 5

## Multimodal Traffic Studies

- 5.1 INTRODUCTION..... 5-1**
- 5.2 MULTIMODAL TRAFFIC STUDIES**
  - A. General..... 5-2
  - B. Level of Service Studies ..... 5-4
  - C. Pedestrian Studies..... 5-8
  - D. Bicyclist Studies..... 5-10
  - E. Safety Evaluations ..... 5-13
  - F. Parking/Access Studies ..... 5-13
  - G. Noise Studies..... 5-14
- 5.3 INTERSECTION TRAFFIC CONTROL DEVICES**
  - A. Traffic Signals ..... 5-17
  - B. Roundabouts ..... 5-17
  - C. Alternate Traffic Control Devices ..... 5-18
- 5.4 TRAFFIC SIGNING AND PAVEMENT MARKING**
  - A. General..... 5-19
  - B. New Subdivisions ..... 5-19
  - C. Capital Projects..... 5-19
- 5.5 MAINTENANCE OF TRAFFIC DURING CONSTRUCTION ..... 5-20**
- 5.6 AT-GRADE RAILROAD CROSSINGS ..... 5-20**
- 5.7 REFERENCES ..... 5-21**

## 5.1 Introduction

The purpose of this chapter is to provide principles and guidelines for the analysis of the transportation network to support the design of safe, efficient, and coordinated transportation facilities for all modes, in accordance with the County's Complete Streets policy.

The street types set forth in Chapter 1 contains criteria for classifying roads based on their function and includes information concerning typical street sections. This chapter presents analysis to be used in the preparation of multimodal traffic studies. Study results shall inform the design of streets and intersections to improve safety and mobility for all modes of travel. As noted in Chapter 1, the mobility and convenience of one user should not be prioritized over another user's safety, and options that reduce serious injuries and fatalities should be prioritized over the reduction of property damage or minor injuries. Often, this approach will cause facilities for people walking and bicycling to be prioritized over motor vehicle level of service goals.

Guidelines are set forth for parking facilities and noise impacts for the intended land use. Requirements for traffic control devices, such as signs and signals, as well as street/highway/intersection lighting and at-grade railroad crossings, are presented. Problems associated with maintenance of traffic during construction are also discussed.

This chapter uses the term "traffic" to refer to all modes of travel: walking, bicycling, transit, driving cars, and delivering goods. In sections where studies are relevant to specific modes of travel, they are referenced as pedestrian traffic, bicycle traffic, motor vehicle traffic, etc., at least in the first instance of the term in that section.

## 5.2 Multimodal Traffic Studies

### A. General

There are six types of traffic studies considered in this Manual:

- Level of service studies for motor vehicle traffic determine the level of delay under existing conditions and identify roadway, intersection, and traffic control configurations needed to accommodate future motor vehicle traffic volume without unreasonable delay.
- Pedestrian access studies, including (1) pedestrian crossing studies to determine location and need for pedestrian crossing measures at intersections and midblock locations; (2) pedestrian connectivity studies to determine the need and location of pathways that connect between destinations and to/from transit stops; and (3) ADA accessibility studies to evaluate the accessibility of the pedestrian network for pedestrians with disabilities.
- Bicycle level of traffic stress (LTS) studies evaluate roads with regard to the safety and comfort of people bicycling. In addition, bicycle connectivity studies determine the need and location of bicycle facilities that connect between destinations
- Safety evaluations are conducted to determine patterns of past crashes, identify the causes, and develop means to alleviate problems identified. Safety evaluations also consider conflicts observed in the field, as well as absence of adequate accommodations for all modes of travel in order to promote safety for all road users.
- Parking/access studies identify parking regulation requirements, the need for motor vehicle parking, both on and off-street, and evaluate off-street parking access to/from the adjacent roadway. Bicycle parking is also included.

- Noise studies determine whether noise abatement or mitigation measures are appropriate in the planning for and development of residential and other noise-sensitive land uses.

In combination, when conducted properly, these studies ensure that roadways and intersections, whether designed as part of a capital project or a subdivision, will be capable of performing their intended purpose safely and efficiently and will become a part of a balanced and coordinated transportation system.

Project plans shall be consistent with the approved traffic study. If a change in land use or a major revision to the project's plans is made, a revised traffic study is required.

#### 1. Scope of Studies

Due to the unique nature of every project and conditions where one or more studies may not apply, some projects may not require all six traffic studies. Each project should be judged individually and the Department of Public Works, in consultation with the Office of Transportation, shall have final authority as to the determination of which studies are appropriate and are to be performed. It should be noted that all development projects are required to conduct an Adequate Road Facilities Test Evaluation as outlined in Chapter 4

To comply with the Howard County Complete Streets policy, all projects, regardless of size, require that sufficient provisions are made for pedestrians, bicyclists, and transit. Level of service studies and safety evaluations, where appropriate, shall be performed for those developer projects which will generate sufficient motor vehicle traffic to have a significant impact on existing facilities. These will include, but not be limited to, all subdivision and/or land developments of an ultimate size that generate greater than 100 peak hour trips in the morning or evening. Subdivisions and/or land developments which generate less than 100 peak hour trips may be required to perform a traffic study if DPZ or DPW determines from previous studies that the level of service (LOS) of intersections within the study area is below (worse than) LOS D.

Site development plans do not have to provide an additional traffic study if the study approved with the original subdivision is still valid. All traffic studies shall be required to include Level of Service Analysis for intersections within a 1/2-mile radius from the development. Local street intersections generally do not have to be analyzed unless known operational problems exist at those intersections. Low volume intersections with no known operational deficiencies do not have to be analyzed.

## 2. Study Report Format/Presentation/Content

Though the extent and content of traffic study reports will vary with the needs of the projects being studied, certain guidelines are applicable to all such reports.

The following information, when applicable/appropriate, shall be included in the report:

- Cover Sheet (include name and location of project, developer, Design Professional, date, etc.)
- Table of Contents
- Scope and Purpose
- Summary of Existing Conditions and Description of Proposed Development
- Design Criteria – design data shall be within one (1) year of Sketch Plan submittal with school in session
- Level of Service Study of Intersections and Links- include volumes, level of service and

required geometrics (number of lanes, length of turning lanes, etc.)

- Safety Evaluation - include crash history, analysis, conclusions, and proposed improvements
- Pedestrian Study - include projected pedestrian needs for walking to destinations and transit stops within a minimum distance of one-half mile (defined by a one-half mile radius from the site of the proposed development) and methods proposed to provide for pedestrian travel, as well as how the project can contribute to the goals of the *Pedestrian Master Plan* (Ref. 1).
- Bicycle Study – include Level of Traffic Stress analysis for bicycle trips to destinations and transit stops with a minimum of two miles; identify potential connections to existing or proposed bicycle facilities within a minimum of two miles, as well as how the project can contribute to the goals of the *Bicycle Master Plan* (Ref. 2)
- Parking Study (if appropriate) - include projected parking demand and proposed accommodations
- Summary of Conclusions and Recommendations - roadway classifications, traffic signals, auxiliary lanes, etc.
- Appendix - include calculations, sketches, backup data, etc.

All reports shall be typewritten and reproduced on 8-1/2" x 11" paper. Maps, charts, tables, diagrams, and other supporting data often help clarify the presentation and should be included as needed. Maps showing existing and proposed streets and traffic data, major traffic generators, accident locations, and parking areas add greatly to the clarity of the report. The scale of maps may vary to meet their intended purpose.

For capital projects, two (2) copies of the report along with a digital copy in pdf format shall be submitted to the Department of Public Works. Developers shall submit reports to the Department of Planning and Zoning in a digital format during the development review process. All approved and final traffic studies shall be submitted in both PDF and in a native format compatible with Microsoft Excel and Word. The approved and final traffic study files shall be labeled with the approval date, plan number and name. The approved and final traffic study shall be submitted to the following email address: [trafficstudydata@howardcountymd.gov](mailto:trafficstudydata@howardcountymd.gov) at the same time the relevant development plan is submitted for signature to Howard County.

All traffic study reports must be signed by a Registered Professional Engineer and are subject to review and approval by the Chief, Bureau of Engineering for capital projects and/or Chief, Development Engineering Division for developer projects.

The developer's Traffic Engineer should consider the following items during the preparation of the traffic study. If relevant, these items must be discussed, and a remedy to any problem detailed. Items for consideration include:

- Conflict analysis for all modes of travel
- Level of service analysis
- Signalization analysis
- Evaluation of missing or substandard pedestrian and bicycle facilities
- Additional right-of-way needed
- Analysis for additional turn lanes, acceleration, and deceleration lanes
- Analysis of the impact of additional lanes on pedestrian and bicyclist safety and comfort
- Queuing analysis and storage requirements

If phased development is involved, each of the above items shall be analyzed for each phase and the twenty (20) year planning horizon. The planning horizon analysis is used for determining and reserving ultimate right-of-way needs.

### 3. Design Year and Ultimate Development Year

The County's Complete Streets policy requires the update of all County regulations, standards, and plans that relate to transportation. Future updates to the General Plan and other policy documents may set goals relating to the transportation network that should be considered when forecasting future conditions (Ref. 3).

To ensure that streets and intersections are able to fulfill their intended purpose, they shall be planned to account for future conditions and future transportation modes. Studies shall evaluate the scheduled phase and/or completion years of the project and the twenty (20) year planning horizon. The design year for capital projects will be designated by the Department of Public Works.

Future conditions to be evaluated include future land use based on the General Plan as well as anticipated increases in walking, bicycling, transit, and motor vehicle traffic. Future conditions may also include new modes of transportation and new technologies, as established by the Department of Public Works.

When appropriate, consideration should also be given to conditions expected to exist at various time intervals between the scheduled phase and/or completion years so the possibility of staged construction can be evaluated.

## B. Level of Service Studies

### 1. General Requirements

When analyzing intersections in the study, the latest version of the Maryland Department of Transportation State Highway Administration's (MDOT SHA's) Critical Lane Volume (CLV) analysis procedures is the method to be used (Ref. 4).

Level of Service (LOS) is a qualitative measure of operational conditions within a motor vehicle traffic stream, generally in terms of such service measures as speed and travel time, freedom to maneuver, traffic interruptions, and driving comfort and convenience. Six Levels of Service, lettered A through F, have been established to represent a range of operating conditions and the driver's perception of those conditions. Level of Service A is characterized by free-flow speeds and freedom to maneuver, while Level of Service F is characterized by stop-and-go traffic and excessive delay. Safety is not included in the measures that establish service levels.

The minimum level of service to be used in planning of roads and intersections shall be Level of Service D, except within the downtown Columbia cordon line described in Section 4.9.5, where level of service E is acceptable or when revised standards are developed based on updated analysis. The standards for design are different from the requirements of the Adequate Road Facilities Test Evaluation as outlined in Chapter 4. When a design is proposed as part of a mitigation plan for passing the test for Adequate Road Facilities Test Evaluations, the applicable provisions of Chapter 4 should be used. The Traffic Engineer should clearly differentiate between the Adequate Road Facilities Test and other Studies/Evaluations required in Chapter 5.

By specifying a level of service and the traffic volumes desiring to use a given road, the geometrics required to provide that level of service can be determined. There are three steps to be conducted in the study as follows: Collection of current data, projection of traffic data, and level of service analysis. When these studies are properly conducted and their results are taken into consideration in design, the road should be capable of serving its intended purpose.

## 2. Collection of Existing Data

When the project being studied involves an existing road facility, the first step in the level of service study is the determination of existing conditions. This includes not only volumes but, where appropriate, the type of traffic (trucks, buses, cars, bicyclists, pedestrians), directional distribution, turning movements, and roadway data (width, etc.). This information is necessary to determine the

existing level of service and the expected level of service in the future if no improvements are made.

### Roadway Information Required:

- a. Pavement & Lane Widths
- b. Number of Lanes & Lane Configuration
- c. Presence and Type of Pedestrian and Bicycle Facilities
- d. Presence of Parking
- e. Grades
- f. Distance to Lateral Obstructions
- g. Average Highway Speed
- h. Percent of passing sight distance greater than 1500 feet (on two-lane highways only)
- i. Intersection Signal Timing & Phasing

The above information can be obtained from the Department of Public Works and/or a field inspection.

### Traffic Information Required:

- a. ADT (Average Daily Traffic) - total number of motor vehicles passing a given point on an average day (if needed).
- b. DHV (Design Hourly Volume) - the number of motor vehicles passing a given point during the peak hour of an average day (or weekday in industrial areas). On two-lane roads, the DHV is the total number of vehicles, bi-directional, whereas on other highways, it is divided into directional flows.
- c. PHF (Peak Hour Factor) - the ratio of the design hourly volume to the peak rate of flow (PRF) expanded to one hour. For intersections, the peak rate of flow is measured in fifteen-minute periods, while on roadways it is measured in five-minute periods, i.e.,
  - 15-minute peak volume = 200 vehicles
  - $PRF = 200 \text{ veh.} \times 60 \text{ min./hour} / 15 \text{ min.} = 800 \text{ vehicles/hour}$
  - $PHF = DHV / PRF$
- d. D (Directional Distribution) - percentage of the DHV oriented in the predominant direction. The directional distribution is needed on all existing intersections and shall be determined by actual counts.
- e. K-Factor =  $DHV / ADT$  - this information shall be supplied when appropriate.

- f. T (Truck Percentage) - percentage of trucks in the DHV. The truck percentage shall be applied when appropriate. In residential and other areas not strictly influenced by commercial or industrial land use, the truck percentage shall be assumed to be 5%. In commercial and industrial areas or in any location with a large number of trucks, the truck percentage shall be determined by actual counts.
- g. Counts of pedestrians and bicyclists during peak periods.

Sources of traffic information include:

- a. MDOT SHA
- b. Department of Public Works

If traffic data are not available from the above sources, counts will have to be made and converted to an ADT and DHV. A useful source to convert is MSHA Highway Information Services Division's "Maryland Highway Traffic Trends." The factors for the station in "Maryland Highway Traffic Trends" nearest to the study site should be used unless the nearest station is on an interstate route.

Though the Department of Public Works will furnish any current data available in its files, the assembly of the data for analysis is the responsibility of the applicant.

### 3. Projection of Future Traffic Volumes

To ensure that an intersection will be capable of accommodating the demand imposed on it at an acceptable level of service for a number of years beyond its construction, it is necessary to predict future traffic volumes. Changes in the trends of development and income are but a few of the factors that can alter traffic patterns and consequently change projected volumes. Therefore, a necessary requirement is to carefully consider the anticipated future needs in determining traffic volumes for the scheduled phase and/or completion year of the project. Existing traffic volume, background traffic growth, and traffic volume generated by new development must be analyzed individually and then combined for their total impact on a facility.

Existing traffic volumes can be determined by methods set forth in the previous section.

Background motor vehicle traffic growth shall be projected at 2% per year compounded for the first three years of a project, concurrent with the date of the first submission of Sketch, Preliminary Equivalent Sketch, or Site Development Plan Submission. Other background traffic growth rates may be proposed by the developer or required by the Bureau of Engineering or Department of Planning and Zoning if validated field counts exist and other traffic data exists to support a different projection. Use of higher than necessary growth rates may result in unnecessarily wide roads, which reduce safety for pedestrians and bicyclists and create additional impervious surface.

Motor vehicle traffic volumes generated by new development shall be based upon the median values in the most current edition of the Institute of Transportation Engineers (ITE) publication "Trip Generation" that most closely reflect proposed subdivisions and land development plans (Ref. 5). These volumes shall be based on those projects which have been recorded but not yet built and any other projects which have been submitted to the County at the time of submission of the traffic study to the County.

Because trip generation data for walking and bicycling trips is not as readily available as the similar data for motor vehicle trips, caution and judgment must be exercised in applying the trip generation rates. The availability of transit, extensive carpooling, high-quality pedestrian and bicycle facilities, schools within walking distance of homes, and multiple shift industries may warrant their modifications. The goal of the County is to provide additional walking, bicycling, and transit connections to reduce the number of motor vehicle trips generated by the development. In addition, the orientation of trips must be considered.

The use of trip generation rates other than those in ITE's "Trip Generation" is subject to review and approval by the Chief, Bureau of Engineering or Department of Planning and Zoning.



When projecting traffic from projects, accurate determination of the number and type of generation units (i.e., dwelling units, floor area, etc.) is of the utmost importance though the information is generally readily available, when considering a specific subdivision, there may be a multiplicity of proposed land uses along the road under consideration which are in various stages of development, and the determination of the number and type of generation units for the scheduled phase and/or completion year of the project is then not such a straight-forward procedure. The Department of Public Works and/or Department of Planning and Zoning shall be consulted when making this projection.

#### 4. Level of Service Analysis

##### a. General

The level of service analysis can be used in several ways. The existing level of service, the level of service at some future date if no improvements are made, and the geometrics required to provide a desired level of service for a specific volume of motor vehicle traffic can be determined.

A complete level of service analysis may require the study of more than one time period. The peak flow normally occurs twice per day: once in the morning (AM) and once in the evening (PM). The predominant movement during the AM peak is away from residences and toward employment areas, whereas the opposite occurs during the PM peak. Consequently, both of the peak periods should be considered. Normally the hours of peak traffic to and from a development will coincide with the hours of the adjacent peak highway traffic, but cases in which this does not occur are fairly common. An example is a shopping center located along a minor arterial. Though the peak flow on the arterial may occur between 5:00 and 6:00 PM on weekdays, the shopping center's peak may occur on a Saturday afternoon between 2:00 and 3:00 PM. Such a situation may require analysis for several time periods. The normal procedure, however, is to analyze the DHVs developed by traffic projection for the AM and PM peak hours.

##### b. At-Grade Intersection (Interrupted Flow)

At-grade intersections can be controlled by several means, such as basic right-of-way rule, yield, two-way stop, four-way stop, roundabout, and signalization. The selection of the appropriate intersection control will consider safety evaluation, compatibility with controls at adjacent intersections, and *Manual on Uniform Traffic Control Devices* (MUTCD) warrants in addition to level of service (Ref. 6). Roundabout control should be evaluated at all intersections where improvements are being considered, consistent with MDOT SHA practice. More information about at-grade intersection analysis is provided in Section 5.3.

##### c. Level of Service Study Results

The primary function of a level of service study is the determination of the intersection geometrics required to provide a desired level of service in the design year.

The number of lanes required on either a through road or at an intersection can be determined and the need for auxiliary lanes as well as their length can be established.

The need for signalization can be determined from the projected traffic volumes and the intersection designed to accommodate it.

When used in conjunction with the parking study, the level of service study indicates where on-street parking will have to be eliminated and thus where additional off-street parking may be needed.

Where a development in a given area is projected to be phased over a long period of time, staged construction should be considered and the level of service study used to determine when the various stages of construction should be proposed for completion.

## C. Pedestrian Studies

Safety and general community well-being are greatly enhanced by consideration of and provision for people walking. The best scenario of our future is a built environment that makes walking safe, comfortable, and useful for access. People have the right to walk along any public street or road except for limited access highways and other facilities where they are prohibited by law. Careful planning and design of sidewalks, separate walkways and/or shared use paths, and improved crossings benefit not only pedestrians but also motorists due to reduced conflicts.

For developer projects, consult the “Subdivision and Land Development Regulations” for sidewalk requirements on subdivision streets. Most street types as described in Chapter 1 include sidewalks on both sides (Ref. 7).

The needs of pedestrians can be determined in several ways. Review of the zoning map and submitted development plans should give insight as to what areas may be subject to heavy pedestrian activity such as schools, libraries, community centers, churches, meeting halls, and transit stops. Existing problems can be identified by the safety evaluation. Regulations pertaining to sidewalk construction by developers are presented in the “Subdivision and Land Development Regulations.”

Sidewalks shall be constructed where required by the “Subdivision and Land Development Regulations” and the street types in Chapter 1 of this manual. In addition to requiring sidewalks in residential areas, these regulations state that sidewalks may be required within commercial and industrial subdivisions “on advice of the Department of Public Works.” Sidewalks in such locations will normally be required because of the substantial number of pedestrians involved and the conflict they experience with motor vehicle traffic, especially where on-street parking occurs.

The Subdivision and Land Development Regulations state that consideration shall be given to the provision of pedestrian walkways or pathways (shared use paths). Such paths are particularly appropriate where facilities along streets are not adequate, where pedestrians can be better accommodated by separated routes, or where paths between parcels provide a more direct route of travel than using sidewalks along streets. Examples of locations that warrant consideration of walkways are schools where walkways can improve safety and floodplains where they can enhance recreational

opportunities. Final determination concerning the land division of a development project with respect to pedestrian walkways will be made by the Department of Planning and Zoning in accordance with the Subdivision and Land Development Regulations.

The design requirements for pedestrian facilities can be found in Chapter 2.

### 1. Midblock Crosswalks

Midblock crosswalks are intended to improve pedestrian and bicycle connectivity and reduce crash risk to all users of the street. Midblock crosswalks may be an appropriate tool to safely accommodate pedestrians and bicyclists where there is a documented crossing demand and the distance to the nearest intersection crossing location would result in significant out-of-direction travel. However, they are not suitable for all locations and careful evaluation must be performed.

Placement of midblock crosswalks must be based on an identified need. Prevailing guidance suggests that future demand should meet a minimum threshold of 20 pedestrians or bicyclists during an hour and a minimum total of 60 pedestrians or bicyclists during any four hours of the day, not necessarily consecutive hours. However, this demand cannot necessarily be measured directly based on counts, as locations without midblock crossings may be avoided by some pedestrians and bicyclists.

At locations where a shared use pathway intersects both sides of a road, a marked crossing should be considered to facilitate the crossing. In certain instances, realignment of the pathway may be desirable to facilitate a desirable crossing location. If the crossing cannot be provided at the intersection of the pathway with the roadway, it should be located within a reasonable and visible distance of the pathway at a location where sufficient sight distance can be provided.

Professional judgement must be used to estimate future pedestrian or bicyclist volumes, taking into account origins and destinations on each side of the street and the distance to the nearest controlled crossing. Origins and destinations that are frequented by children and the elderly such as schools and senior living facilities should be considered when evaluating need for a midblock crossing. Consideration should also be given to the location of nearby bus stops and the shared use path network.

The roadway should have a minimum vehicular volume of 2,000 ADT. The minimum distance to the nearest alternative crossing location is 300 feet. An alternative pedestrian crossing location may be considered to be any controlled location with a stop sign and marked crosswalk, signalized crosswalk, or grade separated crossing.

The evaluation of a proposed midblock crosswalk location must identify that it will be outside the influence area of adjacent signalized intersections, including the limits of auxiliary turn lanes. The ends of standing queues should be observed not to extend to the proposed location.

The evaluation of the location for a midblock crosswalk must also identify that the location will provide adequate stopping sight distance. Parking restrictions in the vicinity of the marked midblock crosswalk may be required and should be identified in the analysis. Other optional treatments, including curb extensions, may be considered for improving sight distance and reducing pedestrian crossing distance. If sidewalks connecting the crosswalk to established pedestrian generators are not already present, the pedestrian study should identify how they will be provided. If the crossing serves a bus stop, the analysis should evaluate the interface between the bus stop and the midblock crossing; bus stops on the far side of the midblock crosswalk are preferred.

If not already present, a raised median or refuge island is recommended for consideration on a multilane crossing or high-volume two-lane crossing, provided that it does not narrow an on-road bicycling facility or otherwise reduce bicyclist safety.

The need for traffic control or other safety provisions at a midblock crossing shall be analyzed using the method in the Federal Highway Administration's (FHWA's) *Guide for Improving Safety at Uncontrolled Crossing Locations* (2018) (Ref. 9). Traffic control devices at midblock crossings may consist of a combination of the following, depending on volumes, speeds, and site conditions:

- Crosswalk markings
- Signs
- Rapid rectangular flashing beacons (RRFBs)
- Pedestrian hybrid beacons (PHBs, sometimes known as "HAWKS")
- Traffic signals

Design guidance for midblock crossings is provided in Chapter 2, Section 2.4.E.3.d.

## 2. Pedestrian Overpasses and Underpasses

Pedestrian or shared use path overpasses and underpasses across roadways are warranted only where there are high pedestrian and/or vehicular volumes, such as at industrial plants, schools, athletic fields, or theaters; or, where the overpass or underpass provides access across freeways or other barriers. Factors to be considered in addition to volumes include age of pedestrians and accident history. As there is a reluctance on the part of pedestrians relative to convenience and security to use these structures unless they are extremely well designed and take advantage of the natural topography, each location must be studied individually.

It should be noted that pedestrian or shared use path bridges across bodies of water, railroads, etc. may also be warranted to provide connections between locations that would otherwise require long trips.

Details of pedestrian and shared use path overpasses and underpasses are provided in Chapter 3.

## D. Bicyclist Studies

### 1. Overview

Level of Traffic Stress (LTS) is a methodology outlined by Mekuria, Furth, and Nixon in *Low-Stress Bicycling and Network Connectivity* (Ref. 10). This methodology uses readily available criteria including number of lanes, shoulder width, bike lane width, parking lane width, speed limit or prevailing speed, and motor vehicle traffic volume to evaluate the generalized stress levels that bicyclists are expected to experience. This methodology can be used to analyze existing streets and proposed designs.

Once applied to all of the streets in an area, the LTS methodology shows the total connectivity of a network and facilitates an evaluation of destinations served by low-stress routes. LTS analysis often reveals “islands” of low-stress connectivity that are separated from one another by higher-stress corridors. These higher-stress corridors prevent people who ride bikes from safely getting from one low-stress area to another.

### 2. Definitions

- a. LTS 1: The level that riders of all ages and abilities can tolerate; this category includes very low-speed and very low-volume neighborhood streets, all separated bike lanes, and all shared use paths.
- b. LTS 2: Tolerated by the mainstream adult population; streets with low volume and low speed motor vehicle traffic.
- c. LTS 3: Tolerated by riders who are “enthused and confident” but still prefer having their own dedicated space for cycling.
- d. LTS 4: Only tolerated by riders who are characterized as “strong and fearless.”

### 3. Criteria

Designers should refer to the criteria below to determine the LTS of existing and proposed roadways. Separated facilities such as separated bike lanes and shared use paths are classified as LTS 1. As a result, those infrastructure types are not included in the below tables.

As noted in Chapter 1, Designers will use LTS 2 as the minimum standard for accommodation of bicyclists in their projects. In addition, designers will strive to provide LTS 1 connections to county schools, county parks and county libraries within half a mile of the project (defined by a one-half mile radius from the site of the proposed development).

For development projects in proximity of a county school, county park, county library, or other specified location, a multimodal transportation study will be submitted to DPZ along with the first submission of the Sketch, Preliminary Equivalent Sketch Plan, or Site Development Plan if subdivision is not proposed. Specifically, the study shall investigate connections to:

- County parks, libraries, Transit Oriented Developments as defined by Howard County, US Route 40 from the Howard County line at the Patapsco River west to the interchange with Interstate 70, Main Street in Ellicott City from the Patapsco River to Rogers Avenue, and Main Street in Elkridge from Route 1 to Washington Boulevard within a 0.5 mile radius of the development and include recommendations/concept level design for improvements for a connection to each identified location
- Each elementary and middle school within a 1 mile radius of the development and include recommendations / concept level design for a connection to each identified school which would result in a route of 1 mile or less from the development
- Each high school within a 1.5 mile radius of the development and include recommendations / concept level design for a connection to each identified school which would result in a route of 1.5 miles or less from the development

The multimodal transportation study will include concept level design for continuous pedestrian connection suitable for an elementary school student to walk to the school, park, and/or library and an LTS1 connection to the school, park, and/or library within the study areas defined above. Approved concepts will be incorporated into updates to Howard County planning documents, including the Bicycle and Pedestrian Master Plans.

Multimodal Traffic Studies

Design guidance for bicycle facilities is provided in Chapter 2, Section 2.2.D.1, and guidance for selecting the appropriate bicycle facility is provided in Section 2.2.D.2. For the design of bicycle facilities along new streets, Designers should use the Street Types described in detail in Section 1.3.C.

a. Mixed traffic

Number of Lanes	Effective ADT**	Prevailing Speed*						
		≤ 20 mph	25 mph	30 mph	35 mph	40 mph	45 mph	50+ mph
Unmarked 2-way street (no centerline)	0-750	LTS 1	LTS 1	LTS 2	LTS 2	LTS 3	LTS 3	LTS 3
	751-1,500	LTS 1	LTS 1	LTS 2	LTS 3	LTS 3	LTS 3	LTS 4
	1,501-3,000	LTS 2	LTS 2	LTS 2	LTS 3	LTS 4	LTS 4	LTS 4
	3,000+	LTS 2	LTS 3	LTS 3	LTS 3	LTS 4	LTS 4	LTS 4
1 through lane per direction • 1-way, 1-lane street; or • 2-way street with centerline	0-750	LTS 1	LTS 1	LTS 2	LTS 2	LTS 3	LTS 3	LTS 3
	751-1,500	LTS 2	LTS 2	LTS 2	LTS 3	LTS 3	LTS 3	LTS 4
	1,501-3,000	LTS 2	LTS 3	LTS 3	LTS 3	LTS 4	LTS 4	LTS 4
	3,000+	LTS 3	LTS 3	LTS 3	LTS 3	LTS 4	LTS 4	LTS 4
2 through lanes per direction	0-8,000	LTS 3	LTS 3	LTS 3	LTS 3	LTS 4	LTS 4	LTS 4
	8,001+	LTS 3	LTS 3	LTS 4	LTS 4	LTS 4	LTS 4	LTS 4
3+ through lanes per direction	any ADT	LTS 3	LTS 3	LTS 4	LTS 4	LTS 4	LTS 4	LTS 4

\* Prevailing speed is defined as the target speed of a proposed roadway or 85<sup>th</sup> percentile speed of an existing roadway. If a speed study is not available, the posted speed of the roadway can be used.  
 \*\* Effective ADT = ADT for 2-way roads; Effective ADT = 1.5\*ADT for 1-way roads

Source: Level of Traffic Stress Criteria for Road Segments, version 2.0, June 2017, Dr. Peter G. Furth's Northeastern University webpage (Ref 11).

b. Bike lanes adjacent to a parking lane

Number of Lanes	Bike Lane Reach**	Prevailing Speed*		
		≤ 25 mph	30 mph	35 mph
1 lane per direction	15+ feet	LTS 1	LTS 2	LTS 3
	12-14 feet	LTS 2	LTS 2	LTS 3
2 lanes per direction (2-way) 2-3 lanes per direction (1-way)	15+ feet	LTS 2	LTS 3	LTS 3
		LTS 2	LTS 3	LTS 3
Other multilane		LTS 3	LTS 3	LTS 3

\* Prevailing speed is defined as the target speed of a proposed roadway or 85<sup>th</sup> percentile speed of an existing roadway. If a speed study is not available, the posted speed of the roadway can be used.  
 \*\* Bike lane reach = bike + parking lane width  
 Notes: 1. If bike lane is frequently blocked, use mixed traffic criteria  
 2. Qualifying bike lane must have reach ≥ 12 feet  
 3. Bike lane width includes any marked buffer next to the bike lane.

Source: Level of Traffic Stress Criteria for Road Segments, version 2.0, June 2017, Dr. Peter G. Furth's Northeastern University webpage.

c. Bike lanes and shoulders not adjacent to a parking lane

Number of Lanes	Bike Lane Width	Prevailing Speed*					
		≤ 25 mph	30 mph	35 mph	40 mph	45 mph	50+ mph
1 through lane per direction, or unlaned	6+ feet	LTS 1	LTS 2	LTS 2	LTS 3	LTS 3	LTS 3
	4 or 5 feet	LTS 2	LTS 2	LTS 2	LTS 3	LTS 3	LTS 4
2 through lanes per direction	6+ feet	LTS 2	LTS 2	LTS 2	LTS 3	LTS 3	LTS 3
	4 or 5 feet	LTS 2	LTS 2	LTS 2	LTS 3	LTS 3	LTS 4
3+ lanes per direction	any width	LTS 3	LTS 3	LTS 3	LTS 4	LTS 4	LTS 4

\* Prevailing speed is defined as the target speed of a proposed roadway or 85<sup>th</sup> percentile speed of an existing roadway. If a speed study is not available, the posted speed of the roadway can be used.  
 Notes: 1. If bike lane / shoulder is frequently blocked, use mixed traffic criteria  
 2. Qualifying bike lane / shoulder should extend at least 4 feet from a curb and at least 3.5 feet from a pavement edge or discontinuous gutter pan seam.  
 3. Bike lane width includes any marked buffer next to the bike lane.

Source: Level of Traffic Stress Criteria for Road Segments, version 2.0, June 2017, Dr. Peter G. Furth's Northeastern University webpage.

d. Bike lanes and mixed traffic on intersection approaches in the presence of a right turn lane

Configuration	Level of Traffic Stress
Single right run lane up to 150 feet long, starting abruptly while the bike lane continues straight; intersection angle such that turning speed is ≤ 15 mph.	LTS ≥ 2
Single right turn lane longer than 150 feet long, starting abruptly while the bike lane continues straight; intersection angle such that turning speed is ≤ 20 mph.	LTS ≥ 3
Single right turn lane in which the bike lane shifts to the left, but intersection angle and curb radius are such that turning speed is ≤ 15 mph.	LTS ≥ 3
Single right turn lane with any other configuration; dual right turn lanes; or right turn lane plus through-right lane.	LTS = 4

Note: "Bike lane" here means either a pocket bike lane (between the right turn lane and a through lane), or a bike lane marked within the right turn lane. These criteria do not apply if a segregated bike lane is kept to the right of a right turn lane and provided a safe means of crossing.

Source: Level of Traffic Stress Criteria for Road Segments, version 1.0, 2012, Dr. Peter G. Furth's Northeastern University webpage.

## E. Safety Evaluations

The Howard County Complete Streets policy establishes safety as the highest priority for County roadways. Requirements for safety studies for developer projects are specified in the Subdivision and Land Development Regulations (Ref. 7). Capital projects or other evaluations conducted by County staff must take a holistic view of safety. A safety evaluation must consider not only crash history but also conflicts as observed in the field, as well as absence of adequate accommodations for all modes of travel. These evaluations make possible the incorporation of design features which may alleviate existing crash causation factors and promote safety for people walking, bicycling, driving, and riding transit.

Crash records are available from the Howard County Department of Public Works' Traffic Division for County-maintained and MDOT SHA-maintained facilities. For MDOT SHA-maintained facilities, crash data must be requested from County Traffic, who is responsible for requesting/obtaining crash data from MDOT SHA's Office of Traffic and Safety. The records from at least the previous three (3), and preferably five (5), years should be obtained and cover all sections of road that may be directly impacted by the proposed project.

Upon accumulation of the records, the data must be organized in a manner to facilitate analysis. The most common method of presentation is the collision diagram, which includes pertinent roadway characteristics together with sufficient information regarding the crashes to recognize any patterns that may exist.

The collision diagram should be carefully studied to determine the cause or causes of crashes and possible remedies. Crashes involving rear-end collisions with left-turning vehicles or vehicles swerving to avoid left-turning vehicles may indicate the need for a separate left-turn lane. Numerous right-angle collisions at a stop-controlled intersection may reflect inadequate sight distance or the need for signalization. Crashes occurring under certain environmental conditions, such as during the night or rain, may indicate the need for lighting or special skid resistance treatment of the pavement. Because people walking and bicycling are most vulnerable to severe injury or fatality when involved in a motor vehicle crash, pedestrian and bicycle crashes must be specifically examined for causation factors.

Crashes that involve people walking and bicycling might indicate a need for a new sidewalk, a new bike lane, a shared use path connection to an adjacent development, a change in the location of a transit stop, or a similar type of improvement.

Safety evaluations also include field review of the entire project site, including connections to existing facilities, and include observation of physical conditions and how all user types navigate the project area. Observations will identify conflicts or "near misses" as well as presence and condition of facilities for walking, bicycling, and riding transit. These observations shall be considered along with crash data to identify potential countermeasures.

The results of such an analysis can be used to design safety improvements to be combined with the proposed project. They may indicate a better location for a development's primary access intersection with an existing road than originally planned, or the County may decide to build a left-turn lane on an existing road in conjunction with improvements planned for a development.

When a safety evaluation concludes that significantly high crash rates exist at a project site because of roadway and/or intersection deficiencies, an improvement plan must be submitted to correct the problem as part of the traffic study.

For capital projects, the AASHTO *Highway Safety Manual* (HSM) may be used to evaluate the crash reduction benefit of safety improvements and, where alternative improvements are being considered, to aid in selecting the best improvements considering costs and benefits (Ref. 12).

## F. Parking/Access Studies

The provision of adequate and properly located and designed parking is vital to the proper operation of the street network. Poorly designed entrances and exits can create congestion and increase crash potential for all road users.

Off-street parking is often needed to assure an adequate supply of parking, promote multimodal traffic flow, and increase safety. Regulations indicating the number of off-street parking spaces and loading facilities needed for various land uses are given in the Zoning Regulations of Howard County (Ref. 13).



Principles of off-street parking design (aisle width, stall arrangement, entrance and exit location, driveway reservoir space, truck circulation to refuse containers or loading zones, etc.) are presented in Chapter 2.

When a capital project is planned on a street that provides on-street parking, a parking study should be conducted if the project might impact the parking supply. The study will include an inventory of the number and location of spaces, posted parking regulations, and occupancy counts during peak parking periods to determine the existing parking utilization. The study shall take into account the adjacent land uses, their usage of street parking or passenger loading, and the availability of off-street parking. Potential parking impacts should be communicated to the public in the early stages of community engagement.

Bicycle parking is important for all destinations. The Designer shall consult the latest edition of *Bicycle Parking Guidelines*, published by the Association of Pedestrian and Bicycle Professionals, for specific guidance (Ref. 14).

## G. Noise Studies

The health, safety and general community well-being is greatly enhanced by the consideration of and provision for noise abatement or mitigation measures as appropriate in the planning for and development of residential land uses.

### 1. Noise Level Threshold

An average level of 65 dBA (A-weighted decibels) at the building curtilage is the threshold beyond which the ambient noise level is considered to be unacceptable to the human ear in a noise-sensitive land use environment. It is the responsibility of the developer of any property in Howard County to ascertain that the noise level, based upon ultimate motor vehicle traffic volumes for the General Plan horizon year or 20 years into the future, whichever is more, within and adjacent to the proposed development, shall be below this threshold.

### 2. Future Noise Level Analysis

The means for projecting future noise levels shall be based upon the Noise Assessment Guidelines published by the U.S. Department of Housing and Urban Development, or Federal Highway Administration's Traffic Noise Model (TNM) as appropriate (Ref. 15, Ref. 16). Concurrent with submission of a Preliminary Plan, a developer shall be required to submit a noise analysis report to the Department of Planning and Zoning if any of the existing or proposed buildings or their curtilages within or adjacent to the subdivision fall within the following locational guidelines:

1. Located within 1000 feet of an existing right-of-way line of Interstate Route I-95 or that segment of U.S. Route 1 from MD 100 to MD 32 or any other roadway where heavy truck traffic is expected to exceed an ADT of 10,000 vehicles.
2. Located within 500 feet of any other existing or proposed Principal or Intermediate Arterial highway right-of-way line.
3. Located within 250 feet of any existing or proposed Minor Arterial right-of-way line.
4. At the discretion of the Chief, Bureau of Engineering or Department of Planning and Zoning a noise study may be required for any proposed development where, based on unusual conditions, it is determined that noise impacts from an existing or proposed highway or rail line are likely to exceed an average of 65 dBA.
5. Located within 500 feet of an existing or proposed rail line.
6. Located within the approved Airport Noise Zone as established by the Maryland Aviation Administration.

### 3. Noise Mitigation Requirements

As a prerequisite to Preliminary Plan approval, mitigation measures shall be proposed by the developer to lower the ambient noise level below the 65-dBA threshold within the building curtilage. Building curtilage shall generally be defined as that area of the site which is used for prolonged human activity (see Figure 5-1). The Department of Public Works or Department of Planning and Zoning shall review the noise analysis and mitigation measures to determine their adequacy and appropriateness. Such measures may include, but not be limited to, noise buffers, noise barriers, building orientation, or the use of acoustical insulation for buildings other than residences.

The following are the noise limit requirements for residential development:

1. The 65-dBA line can come up to the front of the structure;
2. The 65-dBA line can come up to the sides of the structure;
3. The 65-dBA line may not be located on the backyard of a lot with area less than 10,000 square feet;
4. The 65-dBA line may be located at a minimum of 25 feet from the rear building restriction line on lots with area 10,000 square feet or greater. Decks may project 10 feet beyond this envelope; however, applicable zoning restrictions prevail.

In the event that these mitigation measures are not feasible, alternate measures shall be evaluated. Such measures may include increasing unit distances from the noise source, reorienting buildings, their openings, and yards away from the noise source, earth berms, sound walls, heavy evergreen landscaping, etc.

Sound walls shall at a minimum meet construction and product specifications for "Plywall Sound Barrier" by Hoover Treated Wood Products, Inc., or an equivalent. Construction and product specifications shall be included on the appropriate plan for County review and approval.

Building construction materials may be used to reduce interior sound to 45 dBA in residential units if it is agreed by the County that exterior abatement cannot be performed to the 65 dBA standard.

In situations where the Bureau of Engineering or Department of Planning and Zoning determines that lesser setback is allowed, the following standard note shall be added to the record plat or site development plan:

*"The contour line drawn on this plan is advisory as required by the Howard County Design Manual, Chapter 5, revised August 2017 and cannot be considered to exactly locate the 65-dBA exposure. The 65-dBA exposure was established by Howard County to alert developers, builders and future residents that areas beyond this threshold may exceed generally accepted noise levels established by the U.S. Department of Housing and Urban Development."*

5. All noise evaluation locations shall be measured 5' (average ear level) above the proposed grade or deck elevation at the defined limits found in this section.

Figure 5-1. Curtilage.

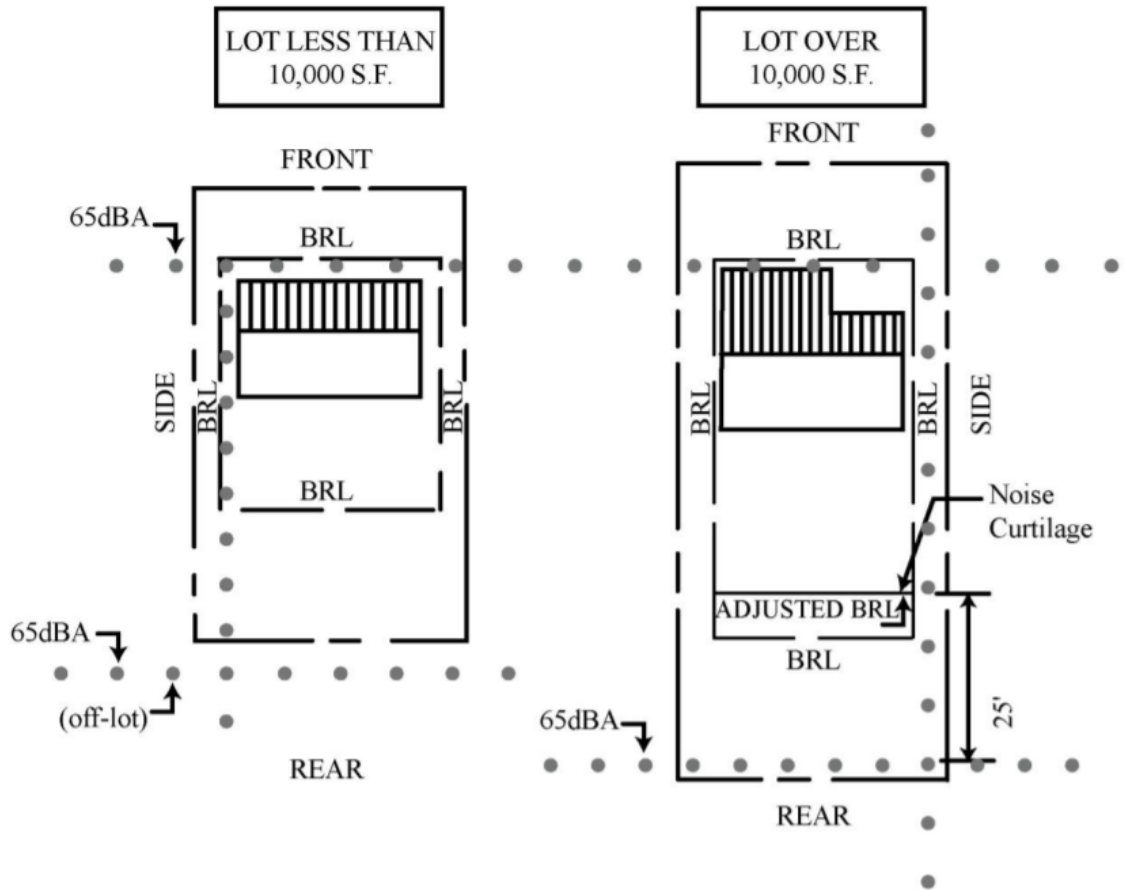

## 5.3 Intersection Traffic Control Devices

Prior to selection of a specific intersection control device, studies must be performed consistent with the requirements outlined in section 5.2, using geometric design outlined in Chapter 2 to develop conceptual layouts. Specific devices which may be evaluated include:

### A. Traffic Signals

Traffic signals should be installed where it has been clearly demonstrated that they will significantly increase the efficiency of an intersection. MUTCD warrants will be used as the basis for such a determination (Ref. 6).

Though both the determination of need and design of traffic signals is a function of either the Howard County Department of Public Works or MDOT SHA, consideration should be given to their requirements during design of the intersection. The Department of Public Works may require installation of underground conduits and signal supports during the initial construction so as to reduce the cost of and disruption caused by installation of the signal system when it is installed in the future.

Current procedures to be followed and cost responsibility for traffic signals are set forth in the MDOT SHA policy directive entitled "Installation and Maintenance of Traffic Signals on the State Highway System" and the latest "Subdivision and Land Development Regulations" (Ref. 17, Ref. 7). The actual cost responsibility for each proposed signal will be determined by the Chief, Traffic Division, Bureau of Highways.

Specific design considerations for signalized intersections are provided in Chapter 2.

### B. Roundabouts

Roundabouts are circular intersections with specific design and traffic control features. These features include Yield control of all entering traffic, channelized approaches, and appropriate geometric curvature to ensure that travel speeds on the circulatory roadway are low. The advantages of a properly located and designed roundabout over other intersection traffic control devices include:

- Improved intersection operation – roundabouts can accommodate higher left-turn volumes than other intersection control devices.
- Lower crash rates and crash severity – roundabouts reduce the number of traffic conflict points and vehicle speeds and provide a clearer indication of the driver's right-of-way compared to other intersection traffic control.
- Cost – roundabouts that do not require significant roadway realignment typically require similar pavement area and right-of-way to a four-legged intersection, while having lower operating costs than a traffic signal.
- Improved Aesthetics – roundabouts also provide an opportunity to improve the aesthetics of an intersection with landscaping in connection with community enhancement projects.

It is important to distinguish that these distinct features of a roundabout are not applicable to other circular intersections, such as rotaries and neighborhood traffic circles. All roundabout studies and design shall be conducted in conformance with MDOT SHA's "Roundabout Design Guidelines October 2012" and the NCHRP Report 672 "Roundabouts: An Informational Guide Second Edition", or latest editions (Ref. 18, Ref 19).

When conducting a study for a potential roundabout, it should be noted that single-lane roundabouts are preferable to multilane roundabouts, which can be less effective at controlling speeds and are more difficult for pedestrians and bicyclists to navigate. The ability to provide appropriate pedestrian and bicycle accommodation should be considered in selection of the intersection type. For more information on design of roundabouts, including pedestrian and bicycle accommodation, see section 2.4.C.

### **C. Alternate Traffic Control Devices**

Evaluation of alternate traffic control devices (e.g., turn restrictions, channelized left-turn “Florida-T”/half signals, continuous flow intersections) shall be conducted only at the discretion and under the direction of the Howard County Department of Public Works. Traditional intersection traffic control devices such as traffic signals and roundabouts shall be initially studied prior to consideration of any alternate traffic control devices. When considering such alternate traffic control, grade separation shall also be evaluated as an option for comparison purposes.

## 5.4 Traffic Signing and Pavement Markings

### A. General

Signs and pavement markings, which warn, guide, and regulate traffic, both vehicular and pedestrian, are required to ensure the maximum efficiency of the street system. To do so, however, they must be properly designed and installed. All signs and pavement markings shall be designed according to the latest edition of the MUTCD, including interim approvals (Ref. 6).

### B. Standards and Guidelines for Traffic Signs and Pavement Markings in New Subdivisions

These Standards and Guidelines are designed to implement the “Subdivision and Land Development Regulations” that state:

“The developer shall be responsible for... and traffic-control devices.” (Section 16.119, Paragraph 10)

“Traffic Control Devices: Signs, signals, markings, and other devices prescribed to regulate, guide, or warn traffic.” (Section 16.108(b), Paragraph 61).

“The developer shall erect street names signs and traffic-control devices at each street intersection. These signs and devices shall be consistent with this Code and the Design Manual and shall be approved by the Department of Planning and Zoning, after consultation with the Director of Public Works.” (Section 16.137)

The developer shall be responsible for the material and labor costs in connection with installing all traffic signs on new streets within the development. The developer shall also be responsible for all maintenance costs incurred prior to acceptance of the street into the public street system. The cost of installing any traffic signs or pavement markings on existing County roads or streets that may be required as a result of the development will be borne by the developer.

The developer shall submit the signing and pavement marking layouts to the Department of Public Works for review and approval. Upon approval, the developer shall install the traffic signs and markings at his/her own expense. The developer has the option to pay the County to install the traffic signs. The street name signs will be installed by the Department of Public Works, at the expense of the developer.

The following requirements of Howard County shall also be met:

1. All traffic control at intersections shall be per the MdMUTCD. The typical minor side street in the County is stop controlled. Traffic entering intersection roundabouts shall be controlled by yield signs, that is, entering traffic shall yield to circulating traffic within roundabout.
2. All pavement markings shall be at least five inches wide.
3. Double-yellow centerline stripes are required on all roadways except local streets and cul-de-sac streets.
4. The minimum R1-1 “STOP” sign size is 30” x 30” and the minimum R2-1 “SPEED LIMIT” sign size is 24” x 30”.
5. All sign post used for traffic control signs installed in the County Right-of-Way shall be mounted on 2” galvanized steel, perforated, square tube post (14 gauge) inserted into a 2-1/2” galvanized steel, perforated, square tube sleeve (12 gauge) – 3’ long. A galvanized steel pole cap shall be mounted on top of each post.

### C. Capital Projects

The signing and marking of capital projects is addressed in Chapter 2.

## 5.5 Maintenance of Traffic During Construction

When designing either an improvement of an existing street or a new street, consideration must be given to maintaining access for all modes of transportation, including pedestrians, bicyclists, and vehicles during construction. The high traffic volumes often found in areas of construction, coupled with what is normally a long construction period, can result in a complex problem which can make an otherwise acceptable design infeasible. The maintenance of traffic, therefore, must be carefully studied during the design process. Traffic to be maintained includes not only driving, but also walking and bicycling.

Three methods of maintaining traffic are available. The first is to stage construction so that the existing facility can be used to accommodate traffic during construction. A four-lane highway, for example, can often be reconstructed by marking on no more than two lanes concurrently. During peak periods, it may be necessary to remove equipment and open more than two lanes. Likewise, a motor vehicle travel lane could be repurposed during construction to serve pedestrian and bicycle traffic.

The second means of maintaining traffic is to divert it to adjacent streets over detour routes using existing roadways. One-way patterns, limitation of parking and certain turning movements, rerouting of transit routes and coordinated signals are some of the means by which such a transfer can be successfully accomplished. Detours for all modes of travel shall be signed in accordance with the latest edition of the MUTCD (Ref. 6). In addition, pedestrian detours must maintain an accessible route in accordance with ADA accessibility guidelines (Ref. 8).

Where traffic cannot be satisfactorily accommodated by the first two methods, construction of temporary detour routes will be necessary. An example is the construction of a new bridge over a stream to replace the existing structure with no change in the road alignment. This situation would require a temporary run-around detour road either over other existing roads in the area or via a specially constructed temporary roadway. Consideration shall be given to the length of detours, especially taking into account the slower speed of bicycle and pedestrian traffic.

As each construction project is somewhat different than any other, no set rules can be given governing the development of the maintenance of traffic plan. Certain principles, however, apply to all situations.

The three means of maintaining all modes of traffic should be studied and a plan developed utilizing some combination thereof. Traffic volumes and speeds, capacities of existing roads, the existing street pattern, availability of land for detour routes, and scheduling of construction activities are among the factors that need to be considered.

The roadway, whether in a construction area or a detour, shall be satisfactory to accommodate traffic at a reasonable speed, which is dependent upon speed approaching the roadway and length of project.

Where rail traffic is interrupted, the railroad affected shall be contacted and a maintenance of traffic plan developed which is acceptable to both the railroad and the Department of Public Works.

The signing and marking of all roadways associated with maintenance of traffic shall be in accordance with the latest edition of the MUTCD and shall conform to County or MDOT SHA "Book of Standards Temporary Traffic Control Devices Typical Applications," where possible (Ref. 6, Ref. 20). Placement of signs, drums, construction equipment, vehicles, construction materials, or other objects shall not block sidewalks or bicycle facilities unless a detour route is provided in accordance with this section.

The complete maintenance of traffic plan, including but not limited to the schedule of construction operations as related to traffic maintenance, the number and widths of lanes to be open during various periods of the day, and the alignment, grade, typical section, and construction details of temporary detour roads, shall be included in the contract drawings, including Site Development Plans and/or Final Road Construction Plans.

The maintenance of traffic plan is subject to review and approval by the Department of Public Works.

## 5.6 At-Grade Railroad Crossings

Protective devices at railroad at-grade crossings shall be in accordance with the latest edition of the MUTCD.



## 5.7 References

- (1) "Howard County Pedestrian Master Plan," Howard County, 2020 or latest version
- (2) "Howard County Bicycle Master Plan," Howard County, 2016 or latest version
- (3) "PlanHoward2030, Howard County General Plan," Howard County, 2012 or latest version
- (4) "Maryland Intersection and Interchange Design & Capacity Analysis Program: Critical Lane Volume Analysis," Maryland Department of Transportation State Highway Administration (MDOT SHA), latest version
- (5) "Trip Generation," Institute of Transportation Engineers (ITE), latest edition
- (6) "Manual on Uniform Traffic Control Devices," Federal Highway Administration (FHWA), 2009 Edition with Revision Numbers 1 and 2 (2012) or latest edition
- (7) "Subdivision and Land Development Regulations," Howard County, latest version
- (8) "Standards for Accessible Design," Americans with Disabilities Act (ADA), (2010) or latest version
- (9) "Guide for Improving Safety at Uncontrolled Crossing Locations," Federal Highway Administration (FHWA), (2018)
- (10) "Low-Stress Bicycling and Network Connectivity," Mekuria, Furth, and Nixon, Mineta Transportation Institute Report 11-19, (2012)
- (11) "Level of Traffic Stress Criteria for Road Segments, version 2.0," Dr. Peter Furth, Northeastern University webpage, (2017)
- (12) "Highway Safety Manual (HSM)," American Association of State Highway Transportation Officials (AASHTO), (2010)
- (13) "Zoning Regulations of Howard County," Howard County, latest version
- (14) "Bicycle Parking Guidelines, 2<sup>nd</sup> Edition" Association of Pedestrian and Bicycle Professionals (APBP), (2010) or latest edition
- (15) "Noise Assessment Guidelines," U.S. Department of Housing and Urban Development (HUD), (2009)
- (16) "Traffic Noise Model (TNM)," Federal Highway Administration (FHWA), (2021), or latest version
- (17) "Installation and Maintenance of Traffic Signals on the State Highway System," MDOT SHA, (latest edition)
- (18) "Roundabout Design Guidelines," MDOT SHA, (2012), or latest edition
- (19) "NCHRP Report 672: Roundabouts: An Informational Guide, Second Edition," National Cooperative Highway Research Program (NCHRP), (2010) or latest edition
- (20) "Book of Standards Temporary Traffic Control Devices Typical Applications," Maryland State Highway Administration (MDSHA), latest edition